



Università degli studi di Napoli
"L'Orientale"



Quaderni delle Collezioni Museali
de "L'Orientale"

3

The Aron Donation: A Collection of Islamic Magic Bowls

Michele Bernardini and Roberta Giunta

Photographs by Valerio Ricciardi

Drawings by Carlotta Passaro

Direzione
Andrea MANZO

Comitato scientifico
Elena CORRADINI
Maria Vittoria FONTANA
Christian GRECO
Lucio MILANO
Giovanni VERARDI

Comitato editoriale
Matteo DELLE DONNE
Roberta GIUNTA
Simonetta GRAZIANI
Romolo LORETO
Chiara VISCONTI

Segretario di redazione
Matteo DELLE DONNE

Comitato di redazione
Arturo ANNUCCI
Noemi BORRELLI
Gilda FERRANDINO
Giulia FORGIONE

Pubblicazione / *Publishing*
Università di Napoli L'Orientale

Impaginazione / *Layout*
Carlotta PASSARO

ISBN
978-88-6719-311-0

Info
www.museorientale.unior.it
museorientale@unior.it



This work is licensed under a Creative Commons Attribution
4.0 International License

UniorPress
Via Nuova Marina, 59 - 80133, Napoli

Contents

PREMESSA	5
PREFACE.....	7
CATALOGUE - PART ONE	9
Roberta Giunta	
CATALOGUE - PART TWO	109
Michele Bernardini	
MAIN BIBLIOGRAPHIC REFERENCES ON ISLAMIC MAGIC BOWLS	241
ANNEX I	243
Anthropomorphic and Zoomorphic Representations	
ANNEX II	247
The 12 Signs of the Zodiac	

Premessa

“Quali sono gli ordini?” chiede lo spaesato Tenente Innocenzi al telefono nel capolavoro di Luigi Comencini *Tutti a casa*. In quella frase di Sordi, c’era insieme il ricordo della caduta del fascismo, della vigliacca reazione all’armistizio dell’8 settembre, sommata all’infamia delle leggi razziali, ma infine la prospettiva di un riscatto, la Resistenza.

La telefonata di Sordi veniva citata spesso da Armando Tagliacozzo, come molti altri film o episodi diventati lessico familiare cinematografico che dava tante risposte e preparava a nuove domande, a nuove speculazioni, di continuo. Una resistenza che nasce da Napoli e che a questa capitale europea, talvolta dimenticata e rinnegata, la famiglia Tagliacozzo ha voluto rendere omaggio con la donazione di una parte importante e significativa della collezione Aron. Napoli, liberatasi da sola dai tedeschi, preparando la strada agli Alleati, città eroica, nobile e plebea con un patrimonio culturale e storico importantissimo e uno sguardo da sempre rivolto verso l’altra sponda del Mediterraneo e il Medio Oriente.

In questo contesto già tradizionalmente vocato a essere ponte con l’Asia, L’Orientale è sembrato a tutta la famiglia il naturale destino per mantenere viva la collezione delle “coppe magiche”. La vicinanza di Armando con i docenti di questa Università ha poi rappresentato un legame forte con il museo Scerrato che veniva realizzandosi. Dalla prima metà del Settecento con la creazione del Collegio dei Cinesi (1732), fondato da Matteo Ripa e destinato ad accogliere giovani Cinesi, l’istituzione iniziò a svolgere le sue funzioni. Dal 1747 ricevette dei giovani provenienti dall’Impero ottomano e fu trasformata in “Real Collegio asiatico”, università dell’Italia unificata, dal 1868 operativa nell’insegnamento dell’arabo, del russo, del turco, dell’urdu e dell’hindi. Nell’immediato dopoguerra divenne Istituto Universitario e nel 2002 Ateneo. Oggi è la sede per l’insegnamento di 47 lingue, la storia, le arti e le istituzioni a esse legate.

Questo meraviglioso complesso culturale è stato indicato fin da subito dalla famiglia Tagliacozzo come destinazione per la sua collezione di “coppe”, frutto di un lavoro senza soluzione di continuità portato avanti in oltre quarant’anni di studio e ricerca.

Complici della scelta certamente gli incontri avuti da Armando con il professor Umberto Scerrato, grande esperto del mondo islamico e raccoglitore

in prima persona di esemplari e libri messi poi a disposizione del contesto accademico. Scerrato, a metà del secolo scorso, tenne il primo insegnamento di Archeologia Orientale e costituì il Seminario di Archeologia Orientale per il quale acquisì i primi materiali per la realizzazione di un museo didattico.

Dagli incontri con il professor Scerrato sono nate le ricchissime collaborazioni e i fertili contatti tenuti da Armando con L'Orientale. Nel caso delle coppe magiche, come ricorda Veronica Prestini che sta aiutando gli eredi Tagliacozzo nella cura della Collezione Aron, il legame con l'Università di Napoli è iniziato negli anni Novanta con Roberta Giunta, allieva di Scerrato, docente di Archeologia e Storia dell'Arte Musulmana e responsabile della Sala Islamica del Museo.

Una collaborazione che ha portato successivamente alla pubblicazione di un primo catalogo (*The Aron Collection, I, Islamic Magic-Therapeutic Bowls*, Istituto per l'Oriente C.A. Nallino, Roma, 2018), mentre un secondo volume dedicato alle coppe divinatorie-rituali dovrebbe essere pubblicato a breve a cura di Michele Bernardini, professore di Lingua e letteratura persiana e Storia dell'Iran medievale e moderno e dell'Impero ottomano a L'Orientale. Uno studioso a cui Armando era legato da profonda amicizia oltre che da stima professionale.

Noi, figli di Armando Tagliacozzo, attraverso questa donazione abbiamo voluto in primo luogo onorare la memoria di nostro padre e di nostra madre Mirella Calò, sua instancabile compagna anche nella ricerca. Vogliamo rispettare così il suo desiderio di lasciare a disposizione degli studenti questi preziosi strumenti di lavoro in uno dei luoghi più rappresentativi e autorevoli della città di Napoli.

Oggetti raccolti nel corso di quella 'febbre' da collezionista che lo ha animato nel suo insaziabile desiderio di conoscere. Ringraziamo il Rettore, il professor Roberto Tottoli, e quanti hanno reso possibile la realizzazione di questo progetto. Siamo felici che tutto ciò avvenga in questo Ateneo, in Via Partenope, nelle sale affacciate sullo splendido golfo di questa città che ci è molto cara.

Roma, febbraio 2025

Tamara, Alessia, Livio e Federico Tagliacozzo

Preface

MICHELE BERNARDINI & ROBERTA GIUNTA

The donation of 108 magic bowls to the Museo Orientale “Umberto Scerrato” of the University of Naples L’Orientale took place in 2023 and marks the culmination of many years of collaboration with our friend Armando Tagliacozzo, founder, with his wife Mirella Calò, of the Aron Collection, one of the foremost collections of Islamic metalwork in Italy—a significant intellectual adventure that began around sixty years ago.

The magic bowls formed a special section of the collection, the study of which was entrusted to us by Armando several years ago. It is one of the most important collections in the world of this class of objects, both in terms of quantity and the breadth and variety of its morphological, functional, decorative, and textual features. Their provenance spans a vast region stretching from Egypt to China and covers a period from the 12th century to the present day. This generous donation, which reflects Armando’s sensitivity and intelligence, offers scholars in the fields of Islamic epigraphy, history, art history, anthropology, astronomy and astrology the opportunity to expand and deepen their knowledge and write a new chapter on the production of this still insufficiently explored class of objects. Furthermore, as it is now housed in a University Museum, this donation will provide our students with an invaluable study resource.

The University of Naples L’Orientale is deeply grateful to Livio, Alessia, Tamara, and Federico Tagliacozzo, the heirs of Armando, who not only fulfilled their wish to donate the collection but also dedicated themselves to its successful transfer to the Museo Orientale.

This catalogue, published on the occasion of an exhibition organised at the Rectorate of L’Orientale University and inaugurated on February 3, 2025, is divided into two parts: the first curated by Roberta Giunta, the second by Michele Bernardini. This division follows the “agreements” made with Armando at the start of the research: bowls without umbo (part one) and bowls with umbo (part two). In both sections, the order of presentation of the objects is primarily morphological, as provenance and dating are still subjects of discussion among scholars. Each object is given two pages: one for the illustration, one for the description. The photographs were taken several years

ago by Valerio Ricciardi. The drawings were created by Carlotta Passaro. The latter, together with Mariano Cinque and with the collaboration of Amanda Antonelli, worked on the layout of the volume.

We would like to thank Veronica Prestini, Carlotta Passaro, Mariano Cinque, Amanda Antonelli, Angela Bosco, Rosario Valentini, Chiara Visconti, Francesca D'Esposito, Alexia Pavan, Lucia De Maio and Elena D'Itria who offered invaluable assistance in organizing the exhibition.

We are confident that in the coming years, this extraordinary collection will lead to new publications and interesting developments in knowledge. This will allow the Museo Orientale to become a true research centre for magic objects, also fulfilling the wish of Armando Tagliacozzo, who had passionately provided the initial fundamental stimulus for both the collection and its study.



Catalogue – Part One

ROBERTA GIUNTA



Introduction

The first part of this volume examines a group of 46 magical objects: 39 metal bowls (nos. 1–39), 2 porcelain bowls (nos. 40, 41), and 5 metal plates (nos. 42–46). As noted in the Preface, all the bowls in this section lack a central umbo, a characteristic shared by the plates.

The first 14 bowls, previously published (Giunta 2018), fall into the category of bowls with a magical-therapeutic function and belong to the early phase of production, typically associated with the Near East during the 12th–14th centuries. Hemispherical in shape and generally small in size, these bowls bear an Arabic inscription in cursive script on the outer wall, just below the rim, outlining their therapeutic properties. The structure of these inscriptions is fairly standardised, typically consisting of an introductory section followed by a list of ailments, injuries, and misfortunes to be prevented or cured, often accompanied by requests for divine favour in securing positive outcomes or averting adverse effects.

In the most common instances, the introductory phrase reads “This blessed bowl is useful for...” (see nos. 1, 3), or “This blessed bowl was written, and it neutralizes all poisons. In it are gathered proven benefits. It is useful for...” (nos. 4–10, 13). In rarer cases, the opening text invokes God to glorify a sultanic authority of high standing within the Islamic community (see, for example, nos. 11, 12).

The variety of ailments, misfortunes, and accidents to be prevented or cured is both extensive and diverse. Among the most frequently mentioned conditions are fever—including hepatic and splenic fever—migraine, colic, abdominal pain, epilepsy, throbbing inflammations, hemorrhages, hemorrhoids, difficulty urinating, and facial paralysis. References to childbirth and nursing are almost always included, such as requests for assistance with labour and increasing the milk supply of a nursing mother. Injuries caused by animals or insects are also commonly mentioned, including bites from snakes and rabid dogs, and stings from scorpions. Less frequently, lizard bites and wasp stings are also referenced.

Accidents related to these last two categories of misfortunes are typically depicted iconographically on the bowls, with notable representations of the snake—sometimes coiled—scorpion, dog, and the pregnant (or nursing) woman, seated with crossed legs (see Figs. 1–4 and Tab. I).



Fig. 1. Bowl no. 10



Fig. 2. Bowl no. 8



Fig. 3. Bowl no. 11



Fig. 4. Bowl no. 9

To ensure the effectiveness of the object's therapeutic powers, many examples also feature depictions of the 12 zodiac signs, the Sun and the Moon, as well as the six planets (Moon, Mercury, Venus, Mars, Jupiter, and Saturn) orbiting the Sun (Figs. 5–8).



Fig. 5. The Sun on bowl no. 11



Fig. 6. The Moon on bowl no. 12



Fig. 7. Venus on bowl no. 13



Fig. 8. Jupiter on bowl no. 14

Many therapeutic formulas also provide instructions on how the object should be used by the requester or an intermediary (“The afflicted person or their agent”). In many cases, this involves drinking from the bowl—sometimes up to three times—water, milk, oil, or water with saffron. For difficult childbirth, its effectiveness is instead ensured by using the liquid in the bowl for washing oneself, while to increase the milk supply of a nursing mother or stop a nosebleed, it is recommended to sniff the water from the object. In some cases, such as with restless babies, robbery, fire, or pillage, direct use of the object may not be necessary, as placing it in a specific environment would be sufficient.

Among the 14 therapeutic bowls, no. 14 stands out as a unique example within the entire class of magical-therapeutic bowls known to date. The bowl, which features a silver inlay of which only sporadic portions remain,

demonstrates highly skilled craftsmanship. The design of both surfaces, based on concentric bands, appears to be inspired by the configuration of the cosmos: the representations of the six planets are found in one of the bands on the interior walls; on the exterior, at nearly the same height as the planets, are the 12 zodiacal constellations, and just below the rim, 28 roundels enclose the representations of the lunar stations (*manāzil al-qamar*; Fig. 9).



Fig. 9. Four of the 28 lunar stations on bowl no. 14

This is the only representation of the lunar stations found on all the magical-therapeutic bowls analysed, and one of the rare instances in medieval Islamic metalwork. Some iconographies are comparable to those of the lunar stations on a brass astrolabe, of excellent craftsmanship, produced in 625/1228 by ‘Abd al-Karīm al-Miṣrī. In the case of the astrolabe, the Arabic names of the stations accompany each image. Bowl no. 14 dates to the end of the 13th century, during the reign of the Mamluk sultan al-Nāṣir Muḥammad I b. Qalāwūn, as the inscription surrounding the outer base specifies that the object was made on the orders of one of his officials, Sa‘d al-Dīn Muḥibb al-Kūjukī.

The other bowls, as well as the five plates in this first part of the Catalogue, belong to later productions for which it is not always easy to determine the area and date of manufacture. These have only been hypothesised, with varying degrees of accuracy, pending further research. The hypotheses suggest objects produced in Anatolia or northern Jazira during the 14th–15th centuries (no. 21), Syria or Mesopotamia in the 14th–15th centuries (no. 25), Egypt in the 15th century (no. 15), Syria or Jazira in the 15th–16th centuries (no. 32), India in the 16th–19th centuries (nos. 33–35, 37–39), Iran between the 16th and 20th centuries (nos. 16–20, 22–24, 26–31), Turkey or Iran in the 18th–19th centuries (no. 36), and China in the 17th–18th centuries (nos. 40, 41). The five plates (nos. 42–46) may have been manufactured in Iran between the 16th and 20th centuries. The only example with a certain date is the large Safavid bowl no. 27, which bears the year 1085/1674–75.



Figs. 10a-d. Examples of inscriptions in non-Arabic characters on the magical-therapeutic bowls

Equally problematic is the function these bowls served, which seems to align with that of the bowls with a central umbo discussed in the second part of the Catalogue. Like the older specimens, these bowls are characterised by decorative patterns that ‘carpet’ both the interior and exterior surfaces. However, there are multiple differences, including: the absence of the therapeutic formula – and consequently, the related iconographic representations – the presence of Shi‘ite prayers and formulas, a reduced variety of writing styles, and, most notably, a limited use of magical alphabets in both Arabic and non-Arabic scripts (Figs. 10a-d).

Finally, it is interesting to note that the therapeutic formulas on the older bowls never mention pain, suffering, or misfortunes related to the sphere of love—a theme that, instead, seems to be referenced by the depiction of a pair of human figures (Fig. 11) on three of the five plates in our collection, a motif also frequently found on modern amulets.



Fig. 11. The motif that appears to assure love on plate no. 44

The Aron donation also includes six objects that belong to the sphere of Islamic artefacts, endowed with magical and auspicious properties, produced in an area extending from Syria to Iran between the 11th and 16th centuries: three pendants, two in silver (inv. no. MO1144 - Aron 278 and inv. no. MO1147 - Aron 334), one in copper alloy (inv. no. MO1145 - Aron 296; Figs. 12-14), a bronze pectoral with silver inlay (inv. no. MO1146 - Aron 356; Fig. 15), and two mirrors, one in bronze (inv. no. MO1143 - Aron 174), the other in brass (inv. no. MO1142 - Aron 279; Figs. 16, 17). These objects deserve a specific study and will be published shortly by the Author.



Fig. 12. MO1144



Fig. 13. MO1147 (recto and verso)



Fig. 14. MO1145



Fig. 15. MO1146



Fig. 16. MO1143 (recto and verso)



Fig. 17. MO1142 (recto and verso)

No. 1

Inv. No. MO1149 | Aron 162



Exterior

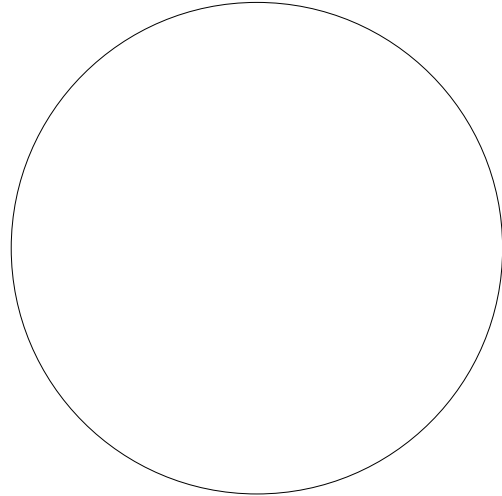

Interior

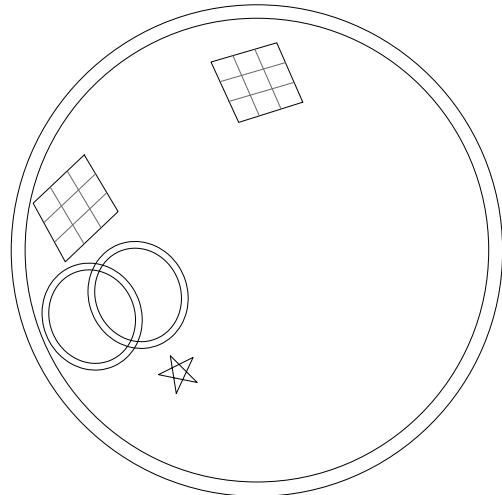

Profile

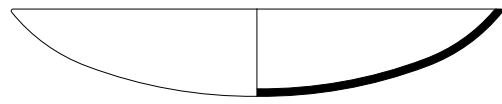

No. 1

Inv. No. MO1149 | Aron 162

Small shallow hemispherical bowl with a straight rim;
black infill in the engravings
Syria or Jazira, 12th-13th century

Dimensions: diam. 11.8 cm, h. 2.4 cm, weight 163.2 g

Condition: Fair; interior engravings range from lightly to heavily worn. Infill largely lost in the interior.

Decorative Patterns

Exterior: Devoid of decoration.

Interior: Dispersed over the centre: four animals, two magic squares, and magical symbols.

Content: A therapeutic magical formula in Arabic cursive beneath the outer rim. Koranic verses and religious expressions in Arabic cursive; Arabic magical characters in Kufic and cursive script; “the seven seals” (Fig. 1); two 3×3 numerical magic squares (Figs. 2, 3); one five-pointed star; zoomorphic motifs including a quadruped with a curled tail, a scorpion, a serpent, and a twin-headed dragon with a knotted body (Annex I).

Comment: Based on its shape, size, and the content of the inscription beneath the outer rim, this specimen belongs to a group of bowls used for magical and therapeutic purposes in the Near Eastern region (see nos. 1–14). The bowl closely compares to specimen no. 2, but the latter is of much less refined craftsmanship. Very similar, if not identical, specimens are present in numerous other public and private collections.

References: Giunta 2018: 21–25, 31–36, No. 1.



Fig. 1



Fig. 2



Fig. 3

No. 2

Inv. No. MO1150 | Aron 287



Exterior

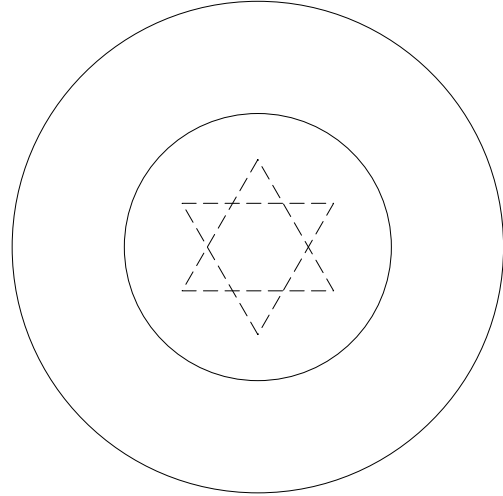

Interior

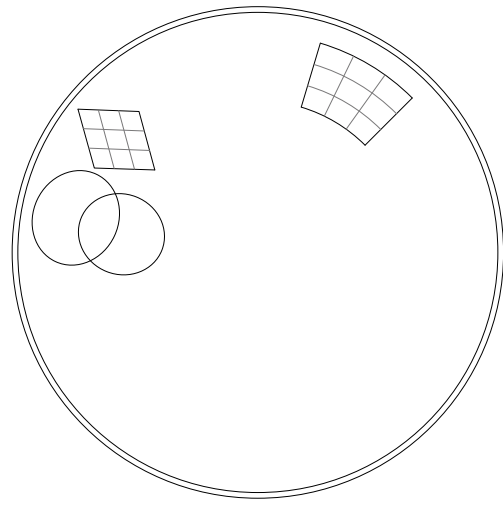

Profile

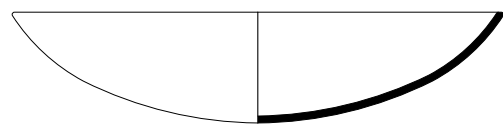

No. 2

Inv. No. MO1150 | Aron 287

Small shallow hemispherical bowl with a straight rim;
black infill in the engravings
Syria or Jazira, 12th-13th century

Dimensions: diam. 10.6 cm, h. 2.4 cm, weight 144.6 g

Condition: Poor; small loss from rim; the engravings, rough and imprecise, are very heavily worn.

Decorative Patterns

Exterior: A six-pointed star on the outer bottom, inscribed within a circle.

Interior: Dispersed over the centre: four animals, two magic squares, and various magical symbols.

Content: A therapeutic magical formula in Arabic cursive beneath the outer rim. Koranic verses and religious expressions in Arabic cursive; Arabic magical characters in Kufic and cursive script; “the seven seals”; two 3×3 numerical magic squares (Fig. 1); one five-pointed star; zoomorphic motifs, including a quadruped with a curled tail, a scorpion, a serpent, and a twin-headed dragon with a knotted body.

Comment: The bowl shares the same characteristics as specimen no. 1, except for the presence of decoration on the underside. The main difference lies in its rough execution; the zoomorphic figures on the inner bottom are almost completely illegible. On the wall, there is a punch mark, possibly made to create a hole for suspending the object (Fig. 2).

References: Giunta 2018: 26–36, No. 2.

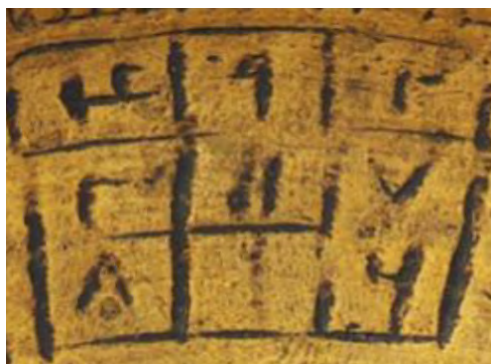

Fig. 1



Fig. 2

No. 3

Inv. No. MO1148 | Aron 403



Exterior

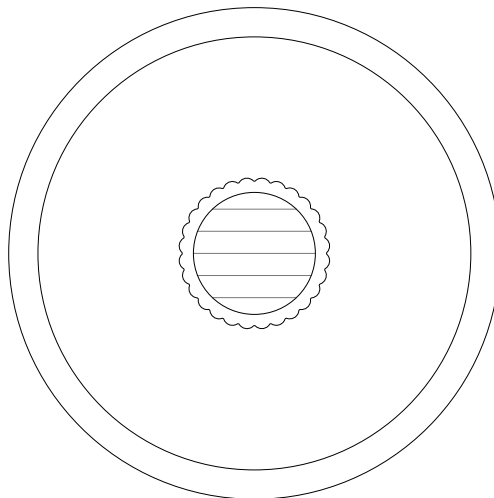

Interior

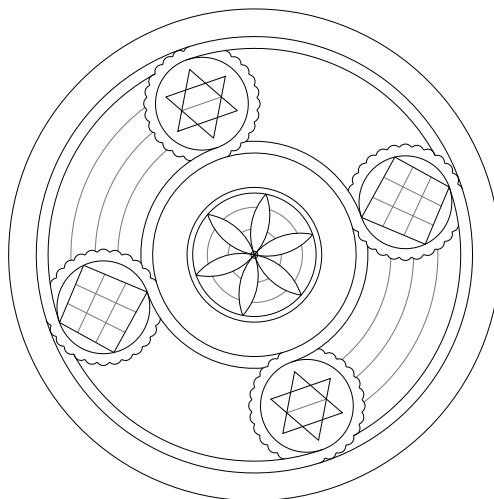

Profile

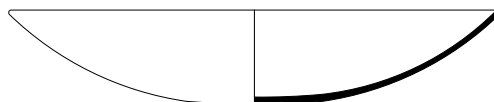

No. 3

Inv. No. MO1148 | Aron 403

Small shallow hemispherical bowl with a straight rim;
white/yellow infill in the engravings
Egypt or Syria, 13th-14th century

Dimensions: diam. 10.8 cm, h. 2.4 cm, weight 77 g

Condition: Fair; significant loss along the rim. Sporadic abrasions on the outside.

Decorative Patterns

Exterior: A scalloped circular medallion at the bottom surrounded by four zoomorphic motifs arranged in a circle.

Interior: Concentric bands, the central band being the largest. It features four equidistant, scalloped circular medallions and a six-petaled flower at the centre.

Content: A therapeutic magical formula in Arabic cursive beneath the outer rim. Koranic verses and religious expressions in Arabic cursive; Arabic magical characters in Kufic script (Fig. 1); two 3×3 numerical magic squares (Fig. 2); numerical and alphanumeric sequences; two six-pointed stars (Fig. 3); zoomorphic motifs including a quadruped with a curled tail, a scorpion, and a serpent with a knotted body (Annex I), and a quadruped with a long tail (partially visible).

Comment: In its size, shape, magical writing, zoomorphic motifs, and the magical formula beneath the outer rim, this bowl is similar to bowls nos. 1 and 2. The decorative pattern, however, does not appear to be attested on specimens from other collections. Equally interesting is the presence of zoomorphic representations on the exterior rather than the interior.

References: Giunta 2018: 37–45, No. 3.



Fig. 1



Fig. 2



Fig. 3

No. 4

Inv. No. MO1139 | Aron 163

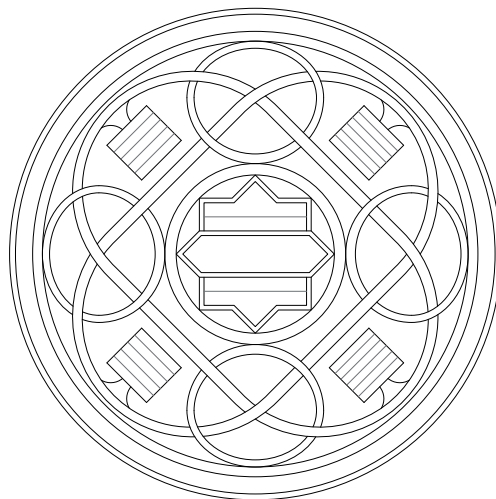
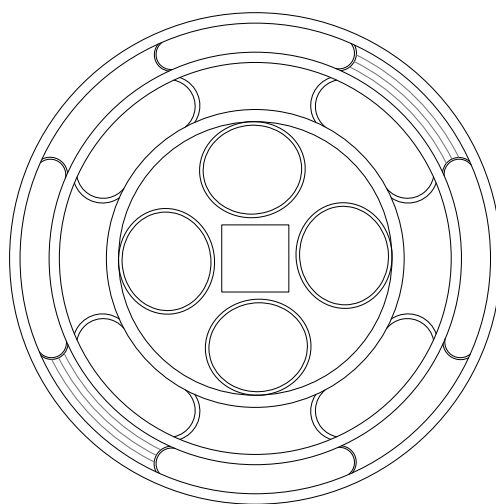
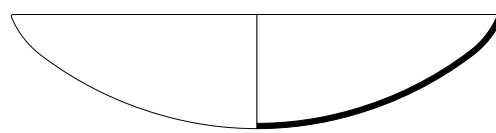
*Exterior**Interior**Profile*

No. 4

Inv. No. MO1139 | Aron 163

Shallow hemispherical bowl with a straight rim;
yellow/brown infill in the engravings
Egypt or Syria, late 13th century

Dimensions: diam. 14.2 cm, h. 3.2 cm, weight 187.5 g

Condition: Poor; an irregular crack crosses the bottom. The inside bottom and the underside are heavily worn and partially illegible, with the infill largely lost.

Decorative Patterns

Exterior: Six narrow ribbons trace two ovals and four circle, intersecting at regular intervals. Four cartouches in the form of *tabula ansata* occupy the bounded spaces towards the extremities of the ovals. A large cartouche in the form of an eight-pointed star sits on the underside.

Interior: The wall features two concentric bands, each enclosing four equidistant oval cartouches, of equal dimension. At the centre are four circular medallions arranged around a square cartouche.

Content: A therapeutic magical formula in Arabic cursive beneath the outer rim. Koranic verses and religious expressions in Arabic cursive; Arabic and non-Arabic magical characters; “planetary characters” (Fig. 1); Arabic numbers; “the seven seals”; zoomorphic motifs, including a quadruped with a curled tail, two birds with spread wings, a scorpion, a serpent with a knotted body, a horse, a lizard, and two cross-legged human figures—possibly pregnant women (Annex I).

Comment: The specimen belongs to the group of bowls with a magical-therapeutic function. The size is slightly larger than that of bowls nos. 1-3. The Arabic formula beneath the outer rim mentions the Mamluk Sultan Lājīn (1296–99), with a plea to God to glorify his victory. The inscriptions in Arabic are fewer in number than the pseudo-inscriptions. In particular, the bowl closely resembles specimen no. 5, both in terms of size, shape, patterns, magical writings, and the content of the texts. For the four medallions on the inner bottom arranged around a cartouche, see also bowl no. 32.

References: Giunta 2018: 46–51, 59–64, No. 4.

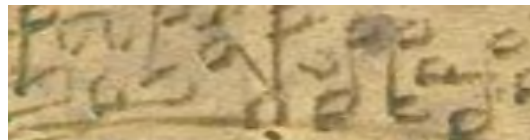
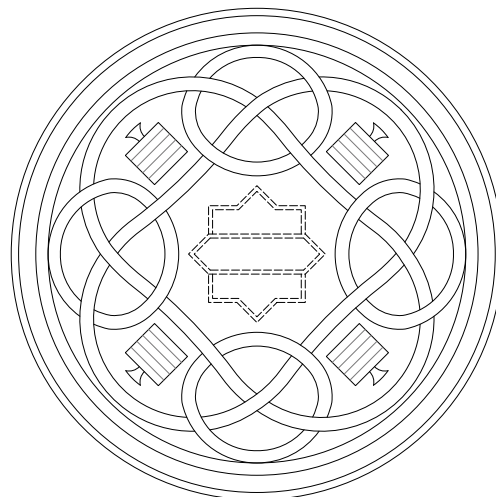
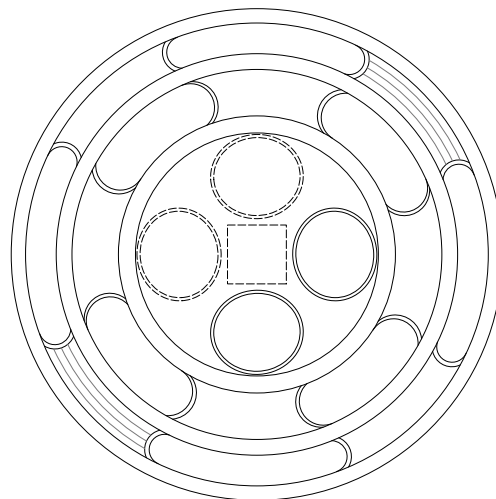
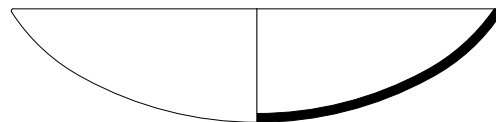

Fig. 1

No. 5

Inv. No. MO1155 | Aron 295

*Exterior**Interior**Profile*

No. 5

Inv. No. MO1155 | Aron 295

Shallow hemispherical bowl with a straight rim;
white/yellow infill in the engravings
Egypt or Syria, late 13th century

Dimensions: diam. 13.9 cm, h. 3.2 cm, weight 184.9 g

Condition: Poor; irregular crack crossing the bottom; interior and exterior bottom heavily worn and partially illegible. Infill largely lost both on the exterior and the interior.

Decorative Patterns

Exterior: Six narrow ribbons trace two ovals and four circle, intersecting at regular intervals. Four cartouches in the form of *tabula ansata* occupy the bounded spaces towards the extremities of the ovals. A large cartouche in the form of an eight-pointed star is located at the bottom.

Interior: The wall features two concentric bands, each enclosing four equidistant oval cartouches, of equal dimension. At the centre are four circular medallions arranged around a square cartouche.

Content: A therapeutic magical formula in Arabic cursive beneath the outer rim. Koranic verses and religious expressions in Arabic cursive; Arabic and non-Arabic magical characters (Fig. 1); “planetary characters”; Arabic numbers; “the seven seals” (Fig. 2); zoomorphic motifs including a quadruped with a curled tail, two birds with spread wings, a scorpion, a serpent with a knotted body, a horse, a lizard, and two cross-legged human figures (Annex I).



Fig. 1

Comment: The bowl is identical to specimen no. 4, including the presence of the name of the Mamluk Sultan Lājīn (1296–99) mentioned in the therapeutic formula. For this reason, it was possible to reconstruct the decorative motif of the inner and outer bottoms, which in this case are completely worn away.

References: Giunta 2018: 53–64, No. 5.



Fig. 2

No. 6

Inv. No. MO1154 | Aron 263



Exterior

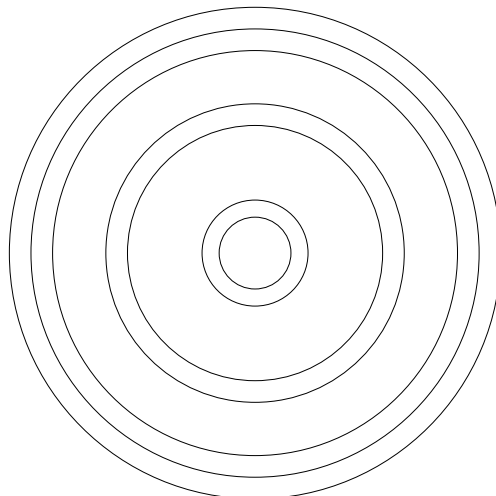

Interior

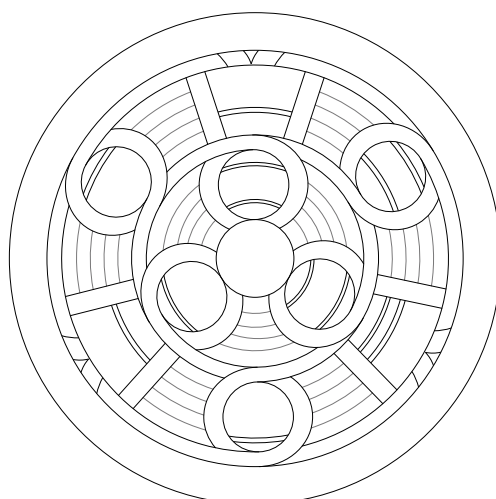

Profile

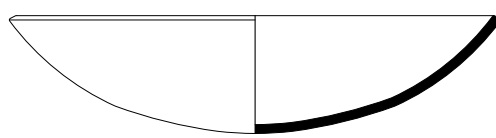

No. 6

Inv. No. MO1154 | Aron 263

Shallow hemispherical bowl with a straight rim;
whitish infill in the engravings
Egypt or Syria, 13th-14th century

Dimensions: diam. 13.8 cm, h. 3.3 cm, weight 211.3 g

Condition: Good; infilling quite badly worn. Traces of corrosion on the external and internal surfaces.

Decorative Patterns

Exterior: Three epigraphic bands, one below the rim, one around the base, and one on the bottom.

Interior: Two groups of three roundels, identical and equidistant, are distributed across two registers; those in the upper register alternate with an equal number of trapezoidal cartouches in the form of a *tabula ansata*. A circular medallion occupies the centre.

Content: A therapeutic magical formula in Arabic cursive beneath the outer rim. Koranic verses in Arabic cursive; Arabic magical characters in Kufic script (Fig. 1); Arabic numbers; anthropomorphic and zoomorphic motifs, including a cross-legged human figures, a quadruped with a curled tail, a scorpion, a lizard, and a serpent (Annex I).

Comment: The bowl exhibits a form and dimensions similar to those of the preceding group (nos. 4, 5) but is slightly heavier. As with these two bowls, the inscriptions in Arabic cursive are fewer in number than the magical and unintelligible texts. Among the latter is an abracadabra, the beginning of which also appears in identical form on bowls nos. 1 and 2. Among the animals, the lizard is not attested on the previous specimens (nos. 1–5).

References: Giunta 2018: 65–72, No. 6.



Fig. 1

No. 7

Inv. No. MO1141 | Aron 169

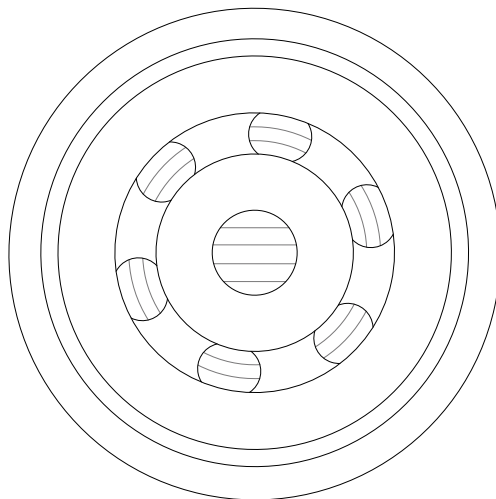
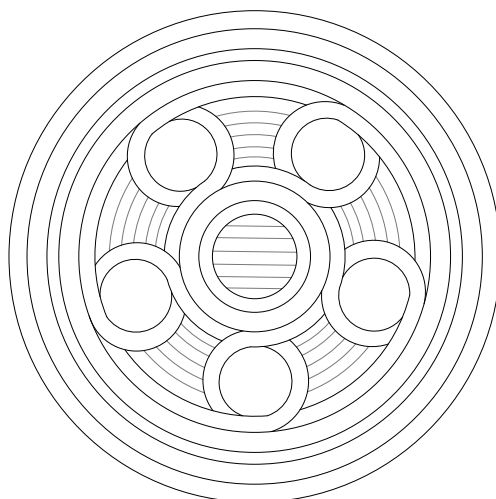
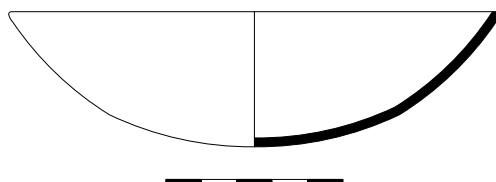
*Exterior**Interior**Profile*

No. 7

Inv. No. MO1141 | Aron 169

Shallow hemispherical bowl with a straight rim;
white/yellow infill in the engravings
Egypt or Syria, 13th-14th century

Dimensions: diam. 13.9 cm, h. 3.8 cm, weight 213.7 g

Condition: Good.

Decorative Patterns

Exterior: Three concentric bands, with the central one enclosing six circular medallions; an additional circular medallion stands out on the bottom.

Interior: A series of concentric bands, the widest of which encloses five roundels formed from a single ribbon and arranged around a central circular medallion.

Content: A therapeutic magical formula in Arabic cursive beneath the outer rim. Koranic verses in Arabic cursive; Arabic and non-Arabic magical characters in Kufic script (Figs. 1, 2); Arabic numbers; anthropomorphic and zoomorphic motifs, including two cross-legged human figures, a scorpion, a serpent with a knotted body, and a lizard (Annex I).

Comment: The bowl shares with the following three specimens (nos. 8–10) the shape, weight, exterior pattern, as well as the presence of magical characters inside the medallions that encircle the anthropomorphic and zoomorphic representations. The roundels arranged on the outer wall around the bottom medallion evoke the representation of the six planets (Moon, Mercury, Venus, Mars, Jupiter, and Saturn) orbiting the Sun. The arrangement of circular medallions on the outer surface is quite common on magic bowls produced in the Syro-Egyptian region during the 13th–14th century.

References: Giunta 2018: 73–77, 93–99, No. 7.



Fig. 1



Fig. 2

No. 8

Inv. No. MO1156 | Aron 170

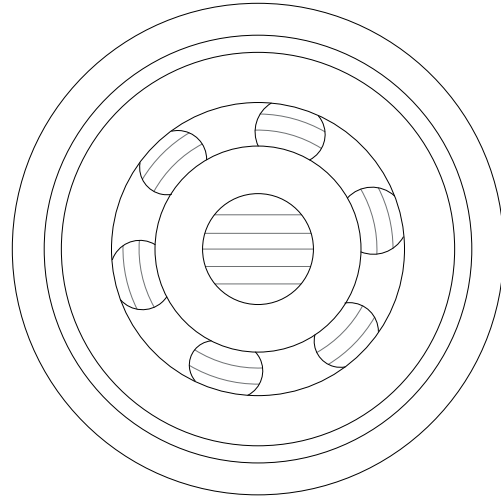
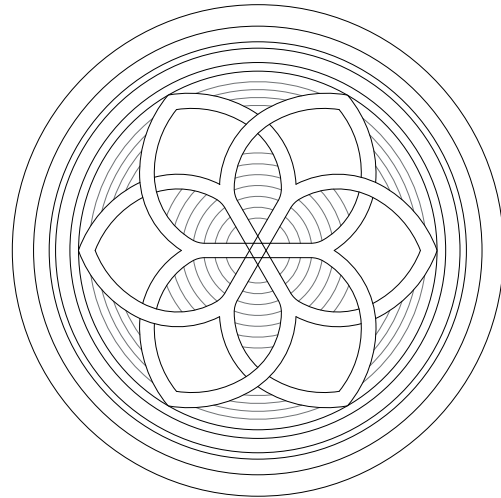
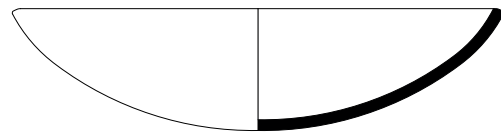
*Exterior**Interior**Profile*

No. 8

Inv. No. MO1156 | Aron 170

Shallow hemispherical bowl with a straight and flat rim;
black infill in the engravings
Egypt or Syria, 13th-14th century

Dimensions: diam. 13.7 cm, h. 3.4 cm, weight 231.5 g

Condition: Good; infill partially lost on the inner bottom.

Decorative Patterns

Exterior: Circular medallions, as seen on bowls nos. 7, 9, and 10.

Interior: A series of concentric bands interrupted by a large six-petaled flower.

Content: A therapeutic magical formula in Arabic cursive beneath the outer rim. Koranic verses and religious expressions in Arabic cursive; Arabic and non-Arabic magical characters in Kufic script (Fig. 1); Arabic numbers; anthropomorphic and zoomorphic motifs, including two cross-legged human figures, two quadrupeds with a curled tail, a scorpion, and a serpent with a knotted body (Annex I).

Comment: This bowl, like specimens nos. 7, 9, and 10, is characterised by concentric lines on the inner surface, interrupted by ribbons that form decorative motifs (in this case, a vegetal element). Almost all the lines conceal a magical and unintelligible script. The concentric arrangement of the writing evokes that of ancient ceramic bowls with texts, primarily in Hebrew or Aramaic, from the Near East (also known as “incantation bowls”). As noted for the previous bowl (no. 7), the decorative pattern on the exterior resembles the arrangement of the planets and the Sun.

References: Giunta 2018: 78–82, 93-99, No. 8.



Fig. 1

No. 9

Inv. No. MO1159 | Aron 168

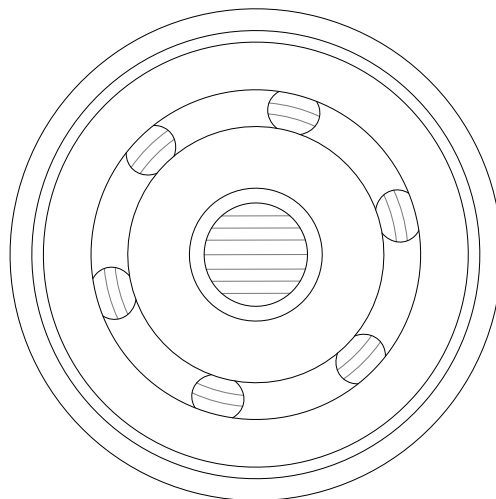
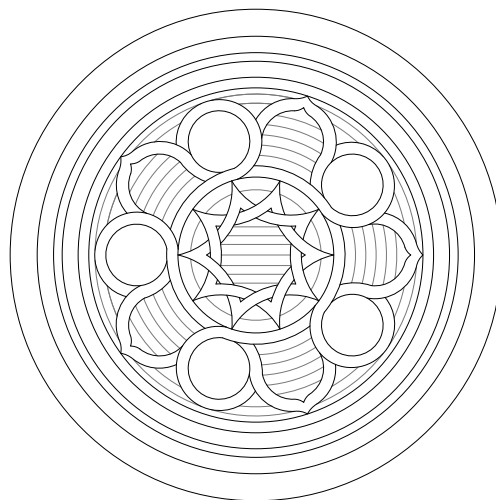
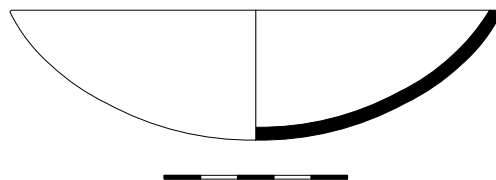
*Exterior**Interior**Profile*

No. 9

Inv. No. MO1159 | Aron 168

Shallow hemispherical bowl with a straight and flat rim;
brownish infill in the engravings
Egypt or Syria, 13th-14th century

Dimensions: diam. 13.4 cm, h. 3.5 cm, weight 248 g

Condition: Good; infill largely lost on the inner and outer bottoms.

Decorative Patterns

Exterior: Circular medallions, as seen on bowls nos. 7, 8, and 10.

Interior: A series of concentric bands interrupted by ribbons forming a nine-petaled flower, five in the shape of arcs and four circular. The petals are arranged around a ten-pointed star formed by the intersection of two pentagons (Fig. 1).

Content: A therapeutic magical formula in Arabic cursive beneath the outer rim. Koranic verses and religious expressions in Arabic cursive; Arabic and non-Arabic magical characters; Arabic numbers; anthropomorphic and zoomorphic motifs, including two cross-legged human figures, a quadruped with a curled tail, a scorpion, and a serpent with a knotted body (Annex I).

Comment: See bowls nos. 7, 8 and 10 both for their shape, dimensions, and exterior decoration, as well as for anthropomorphic and zoomorphic motifs, and the arrangement of the concentric lines on the interior. The ten-pointed star—with concave sides—that stands out on the inner bottom closely compares to that of specimen no. 10. A similar star motif, but with 16 concave sides, is attested on bowl no. 11 and, most likely, on bowl no. 12, whose original bottom has, however, disappeared.

References: Giunta 2018: 83–87, 93–99, No. 9.



Fig. 1

No. 10

Inv. No. MO1152 | Aron 171

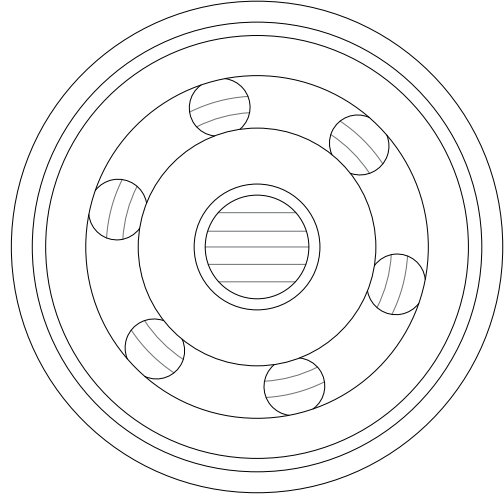
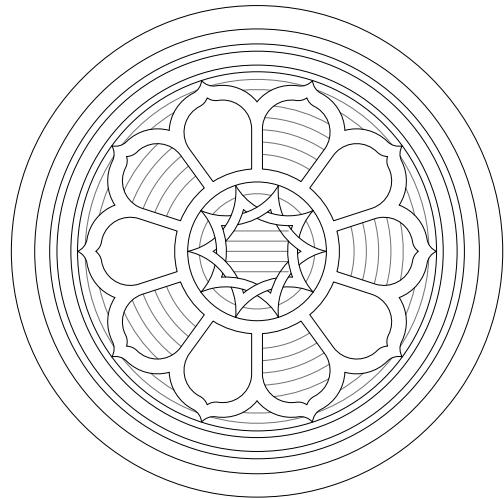
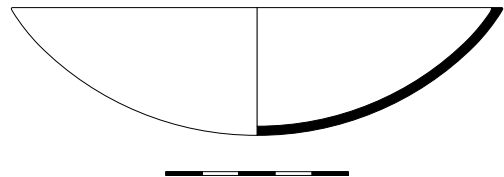
*Exterior**Interior**Profile*

No. 10

Inv. No. MO1152 | Aron 171

Shallow hemispherical bowl with a straight rim;
white infill in the engravings
Egypt or Syria, 13th-14th century

Dimensions: diam. 13.4 cm h. 3.5 cm, weight 215.6 g

Condition: Good; losses of infill, particularly at interior centre.

Decorative Patterns

Exterior: Circular medallions, as seen on bowls nos. 7-9.

Interior: A series of concentric bands interrupted by ribbons that form a ten-petaled flower in the shape of arches, arranged around a ten-pointed star (Fig. 1).

Content: A therapeutic magical formula in Arabic cursive beneath the outer rim. Koranic verses and religious expressions in Arabic cursive; Arabic and non-Arabic magical characters in Kufic (Fig. 2) and cursive script; sequences of Arabic numbers; anthropomorphic and zoomorphic motifs, including two cross-legged human figures, a quadruped with a curled tail, a scorpion, and a serpent with a knotted body (Annex I).

Comment: The decorative pattern on both surfaces of the bowl closely resembles that of the previous specimen (no. 9), which also features a ten-pointed star with concave sides, formed by the intersection of two pentagons. The style of the magical characters is also very similar. These are undoubtedly contemporary pieces, closely associated with specimens nos. 7 and 8, and most likely with bowl no. 6 as well.

References: Giunta 2018: 88–99, No. 10.



Fig. 1



Fig. 2

No. 11

Inv. No. MO1158 | Aron 150

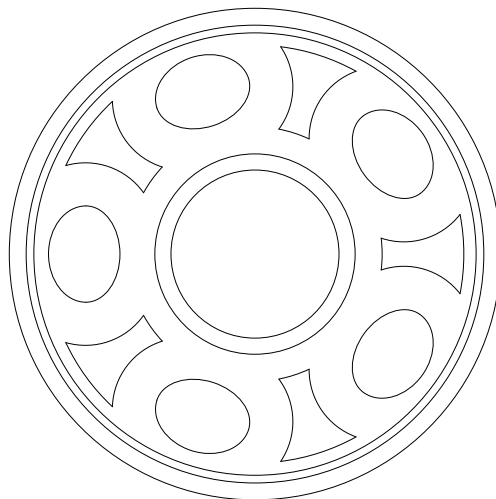
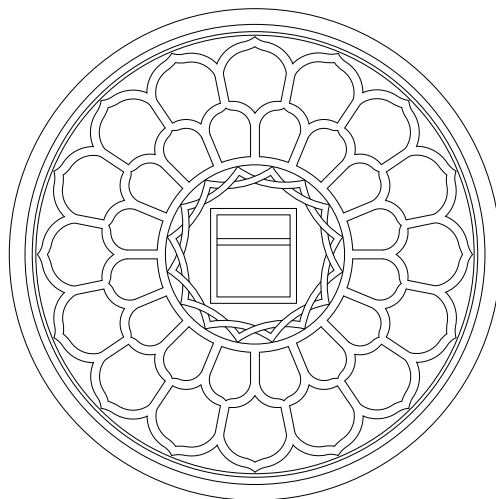
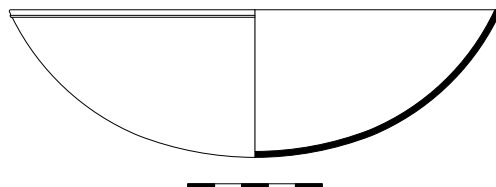
*Exterior**Interior**Profile*

No. 11

Inv. No. MO1158 | Aron 150

Hemispherical bowl with a straight and flat rim;
blackish infill in the engravings
Egypt or Syria, 13th-14th century

Dimensions: diam. 18.2 cm, h. 5.4 cm, weight 511 g

Condition: Poor; base pitted and worn; infill largely lost; substantial parts illegible. Clear traces of scratching on the inner bottom.

Decorative Patterns

Exterior: A large band enclosing five equal and equidistant roundels, alternating with five “funnel-shaped” cartouches.

Interior: Double-corolla flower, with each corolla composed of 16 pointed petals. On the bottom stands the depiction of the Ka‘ba in Mecca (Fig. 1), enclosed within a 16-petaled star formed by the intersection of two octagons.

Content: A therapeutic magical formula in Arabic cursive beneath the outer rim. Non-Arabic magical characters in Kufic script (Fig. 2); anthropomorphic and zoomorphic motifs, including a scorpion, a serpent with a knotted body, two quadrupeds, two cross-legged human figures (Annex I), as well as depictions of the Sun and the Moon.

Comment: The bowl shares its dimensions, weight, and decorative pattern with specimen no. 11 and is larger than the previous specimens (nos. 1–10). Many similar specimens exist, including one from the Borgia collection, preserved at the Capodimonte Museum in Naples, first reported by Adler in 1782. This bowl is known as the “Saladin Type”, as the name of the Ayyubid sultan appears in the therapeutic formula. For many of these specimens, including the one presented here, it is specified that they were manufactured in Mecca. The depiction of the Ka‘ba in Mecca is almost completely erased due to scratches on the bottom, likely caused during the use of the bowl. For the star formed by the intersection of two regular polygons, see also specimens nos. 9 and 10.

References: Giunta 2018: 100–104, 111–15, No. 11.



Fig. 1



Fig. 2

No. 12

Inv. No. MO1157 | Aron 291

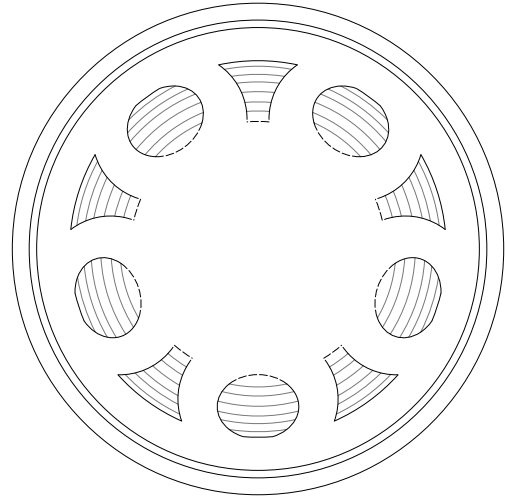
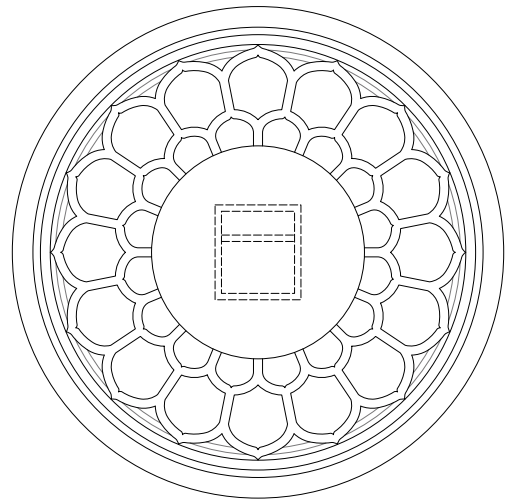
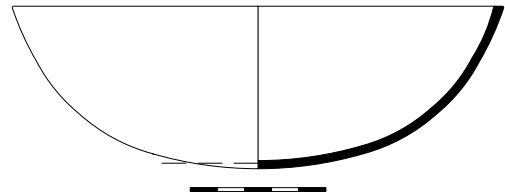
*Exterior**Interior**Profile*

No. 12

Inv. No. MO1157 | Aron 291

Hemispherical bowl with a straight and flat rim;
black and white/gray infill in the engravings
Egypt or Syria, 13th-14th century

Dimensions: diam. 18.1 cm, h. 5.8 cm, weight 573 g

Condition: Fair; original bottom missing, repaired with different material; remaining interior and exterior inscriptions moderately to heavily worn.

Decorative Patterns

Exterior: A large band enclosing five equal and equidistant roundels, alternating with five “funnel-shaped” cartouches.

Interior: Double-corolla flower, with each corolla composed of 16 pointed petals. The depiction of the Ka’ba most likely originally stood out on the bottom, as in specimen no. 11.

Content: A therapeutic magical formula in Arabic cursive beneath the outer rim. Koranic verses (Fig. 1); non-Arabic magical characters in Kufic script; anthropomorphic and zoomorphic motifs, including a scorpion, a serpent with a knotted body, two quadrupeds, two cross-legged human figures (Annex 1), as well as depictions of the Sun and the Moon.

Comment: The bowl is similar to the previous specimen and belongs to the so-called “Saladin type”, bearing the name of the sultan (Fig. 2) and the city of manufacture, Mecca. The main difference between the two specimens lies primarily in the presence of Koranic verses within the petals of the vegetal element on the interior. It can be hypothesised that the bottom of the object was worn away due to scratches on the depiction of the Ka’ba, with very visible scratches observed on specimen no. 11. Additionally, we notice that some traces of white engraved lines remain on the outer surface (Fig. 2).

References: Giunta 2018: 105–15, No. 12.



Fig. 1

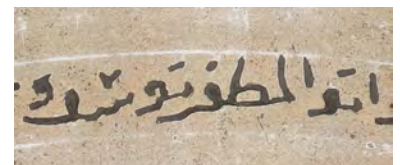

Fig. 2

No. 13

Inv. No. MO1151 | Aron 353



Exterior

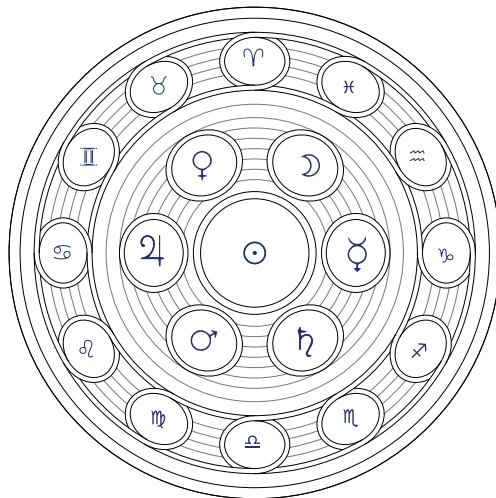

Interior

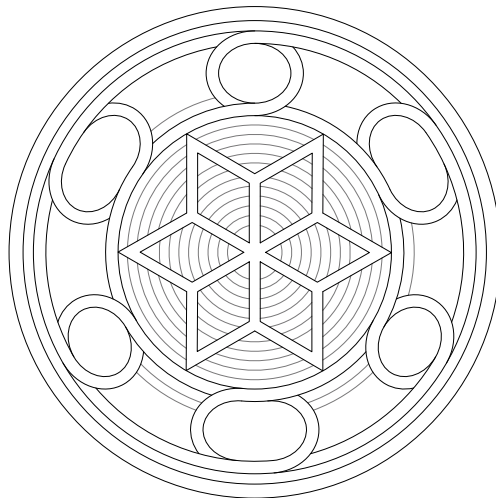

Profile

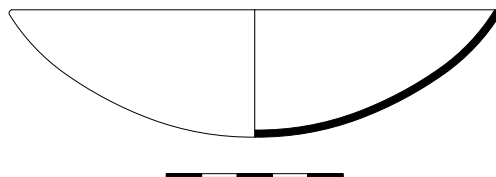

No. 13

Inv. No. MO1151 | Aron 353

Shallow hemispherical bowl with straight rim; silver inlay;
white/yellow infill in the engravings
Egypt or Syria, 13th-14th century

Dimensions: diam. 13.9 cm, h. 3.6 cm, weight 215 g

Condition: Fair; inlay largely lost (Fig. 1); infill moderately to heavily worn. A plug occurs on the wall and has obliterated some engravings.

Decorative Patterns

Exterior: Concentric bands of varying dimensions: the band on the wall encloses 12 roundels, the one at the back contains six. This latter band is arranged around a circular medallion, in which the depiction of the Sun with multiple rays stands out (Fig. 2).

Interior: On the wall, a band encloses three oval cartouches alternating with three roundels. In the background, a six-petaled flower interrupts a series of continuous and concentric lines.

Content: A therapeutic magical formula in Arabic cursive beneath the outer rim. Koranic verses and religious expressions in Arabic cursive; Arabic and non-Arabic magical characters in Kufic script; isolated Arabic letters and numbers; anthropomorphic and zoomorphic motifs, including two cross-legged human figures, a quadruped, a scorpion, and a serpent with a knotted body (Annex I). On the outside, there is a depiction of the six planets arranged around the Sun, along with the twelve zodiac constellations in counterclockwise order (Annex II). The sign of Pisces has been replaced by a plug.

Comment: One of the main distinguishing features of this bowl is the use of the silver inlay technique applied to its inner surface. Despite some differences, the bowl can be compared to specimen no. 14, which is also inlaid and decorated with zodiac constellations and planets. Another distinctive feature of this specimen is the shape of the six-pointed star that stands out on the inner bottom, created by arranging six rhomboid elements side by side.

References: Giunta 2018: 116–21, 130–46, No. 13.



Fig. 1



Fig. 2

No. 14

Inv. No. MO1138 | Aron 137

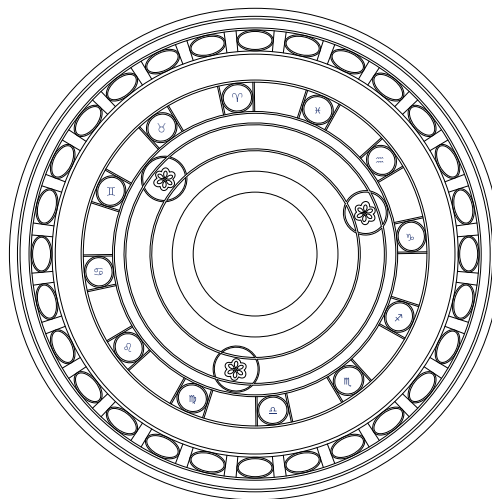
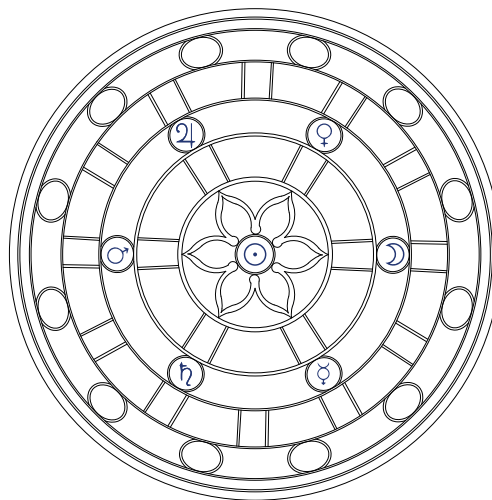
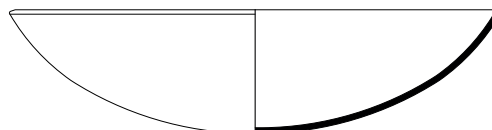
*Exterior**Interior**Profile*

No. 14

Inv. No. MO1138 | Aron 137

Shallow hemispherical bowl with slightly rounded rim;
 silver inlay; white/yellow infill in the engravings
 Egypt or Syria, 13th century

Dimensions: diam. 14 cm, h. 3.5 cm, weight 301.5 g

Condition: Fair; inlay largely lost; infill moderately to heavily worn; some areas of illegible writing and figures.

Decorative Patterns

Exterior: Concentric bands marked off with roundels and cartouches. At the center of the bottom, a six-pointed star was once inscribed within a hexagon.

Interior: Concentric bands marked off with roundels and cartouches. At the center, a six-petaled flower is inscribed within a circle.

Content: A therapeutic magical formula in Arabic cursive beneath the outer rim. Commemorative texts (including the name of the officer); Koranic verses and religious expressions in Arabic cursive; Arabic and non-Arabic magical characters in Kufic script; “planetary characters”; isolated Arabic letters and numbers; anthropomorphic and zoomorphic motifs, including human figures, a quadruped, scorpions, a lizard, a dragon, a mythological creature, and a serpent (Annex I). On the outer surface, there are depictions of the six planets surrounding the Sun, the 28 lunar mansions, and the 12 zodiac signs in counterclockwise order. Due to wear, the latter are hardly discernible.

Comment: This bowl is one of the most important specimens known to date, distinguished by the refinement of its execution, the silver inlay technique (Fig. 1), the richness of its textual content, the variety of magical scripts, and the presence of the artisan’s name—an official at the court of the Mamluk sultans—as well as one of the rare depictions of the 28 lunar stations in Islamic medieval metalwork. Some of these iconographies can be compared with those of a brass astrolabe dated to 625/1228, which is housed at the Ashmolean Museum in Oxford (inv. no. 37148). The bowl undoubtedly belongs to Mamluk production from the first half of the 13th century.

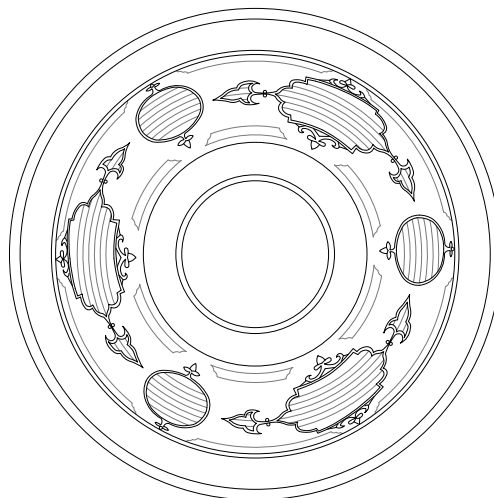
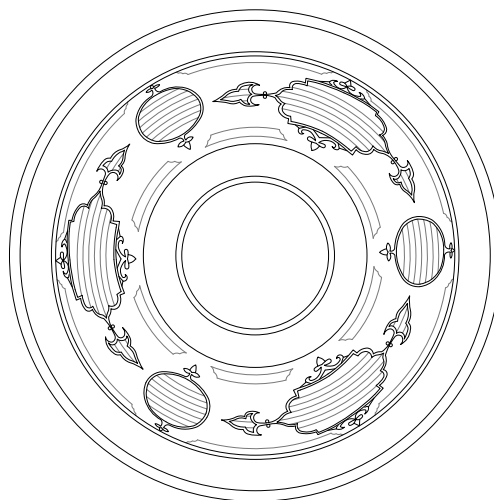
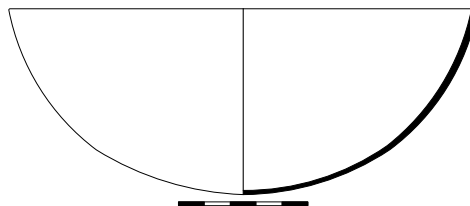

Fig. 1

References: Giunta 2018: 122–46, No. 14.

No. 15

Inv. No. MO1174 | Aron 123

*Exterior**Interior**Profile*

No. 15

Inv. No. MO1174 | Aron 123

Hemispherical bowl with straight rim;
blackish infill in the engravings
Egypt, 15th century

Dimensions: diam. 19 cm, h. 7.53 cm, weight 320.7 g

Condition: Fair; legends very worn out in the interior, both on the wall and bottom.

Decorative Patterns

Exterior: Concentric bands of varying heights. In the central band, three lobed cartouches alternate with three circular medallions. Both the cartouches and medallions feature trilobed floral motifs at their extremities (Fig. 1). A no longer identifiable motif on the bottom within a circular medallion.

Interior: Identical to the exterior.

Content: Kor. 2:255 in Arabic cursive beneath the outer rim; other Koranic verses and religious expressions in Arabic cursive; non-Arabic magic characters in Kufic; sequences of numbers.

Comment: Both the exterior and interior of the bowl feature the same surface organization, but the engravings on the interior are so worn that they are barely legible. For the repetition of the same pattern on both the outer and inner surface, see also bowl no. 33.

References:

Unpublished.



Fig. 1

No. 16

Inv. No. MO1172 | Aron 402

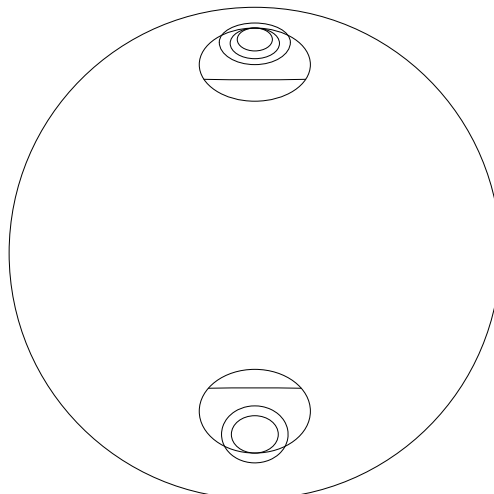
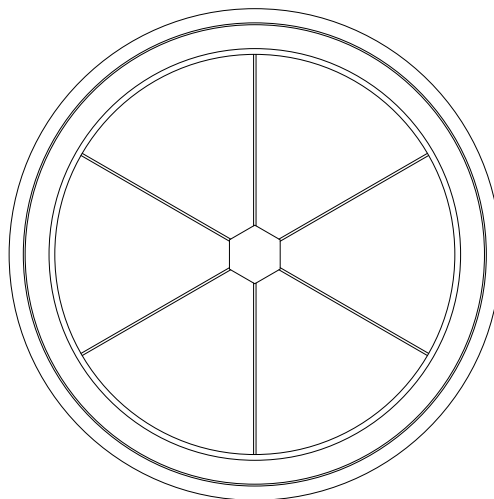
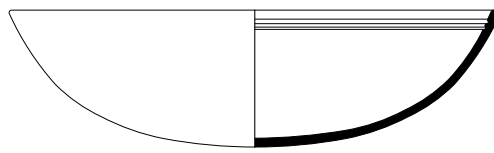
*Exterior**Interior**Profile*

No. 16

Inv. No. MO1172 | Aron 402

Hemispherical bowl with a flat rim; blackish infill in the engravings
Iran, 16th-17th century

Dimensions: diam. 20 cm, h. 4.5 cm

Condition: Fair; significant gap on the wall restored with a patch. Encrustations and abrasions, especially on the inner surface. Infill largely lost both on the exterior and the interior.

Decorative Patterns

Exterior: Two sets of concentric circles on two opposite sides of the wall.

Interior: Six pairs of thin, parallel engraved lines divide the surface into six triangular spaces. Each pair of lines originates from one of the corners of a small hexagonal cartouche that stands out at the bottom.

Content: No inscription beneath the outer rim. Koranic verses and religious expressions in Arabic cursive; Arabic and non-Arabic magical characters in Kufic script (Fig. 1); unintelligible phrases in cursive Arabic; sequences of Arabic numbers; A scorpion to the right of one of the two groups of concentric circles on the outside (Annex I).

Comment: The decorative pattern of the bowl is primarily found on the interior and does not appear to be attested on other objects of this class. The same can be said for both the arrangement of the eight epigraphic and pseudo-epigraphic lines enclosed within the triangular spaces on the interior, and the position of the scorpion on the outer wall, next to one of the groups of concentric circles. These features can be compared to those engraved on the inner surface of bowls no. 1 and 2.

References: Unpublished.



Fig. 1

No. 17

Inv. No. MO1218 | Aron 269



Exterior

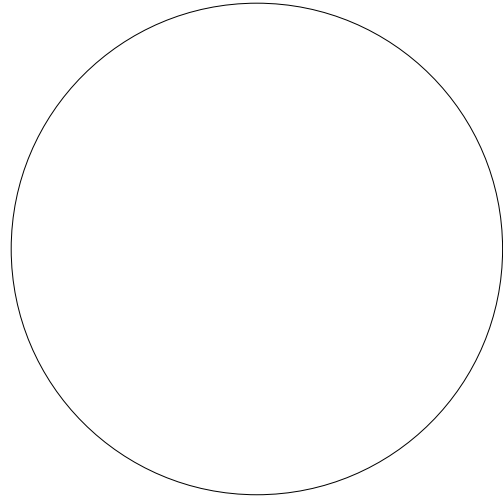

Interior



Profile

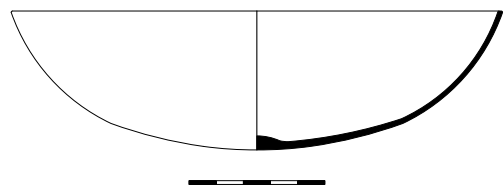

No. 17

Inv. No. MO1218 | Aron 269

Hemispherical bowl with straight rim;
brownish infill in the engravings
Iran, 18th-19th century

Dimensions: diam. 18.12 cm, h. 5.12 cm, weight 395 g

Condition: Good; sporadic traces of corrosion on the outer and inner surfaces.

Decorative Patterns

Exterior: Devoid of decoration.

Interior: Concentric bands, with the main one on the wall enclosing four oval cartouches alternated with four small circular medallions. A large circular medallion on the bottom encloses a cubic building (*turba*) with an oval dome and two lateral minarets. The dome encloses four rows of stones/bricks (Fig. 1).

Content: No inscription beneath the outer rim. Koranic verses and religious prayers and expressions in Arabic cursive; names of the archangels; signature of the artisan or the owner.

Comment: This is the first of three bowls in the collection characterised by an architectural-type decoration occupying the inner bottom (see also bowls nos. 18 and 19). A very similar specimen, though differing in size and shape, is published in Perk, Paksoy (2011: 65-67, nos. 33-35). All these bowls share a plain exterior, the cursive style of the interior writing, and small oblique segments and “sawtooth” bands in the epigraphic fields and between the epigraphic bands. Only in this case is the dome depicted with details of the masonry. This bowl, like specimen no. 18, can also be compared with specimens nos. 35 and 36 for the organization of the cartouches on the inner surface, the styles of writing, and the bands filled with a “sawtooth” pattern (although absent on bowl no. 36).

References: Unpublished.



Fig. 1

No. 18

Inv. No. MO1170 | Aron 268

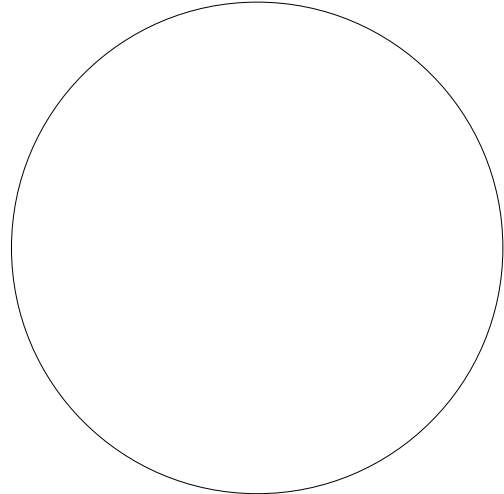
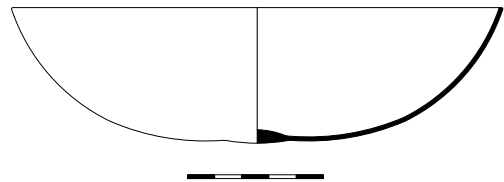
*Exterior**Interior**Profile*

No. 18

Inv. No. MO1170 | Aron 268

Hemispherical bowl with straight rim;
brownish infill in the engravings
Iran, 18th-19th century

Dimensions: diam. 18.13 cm, h. 5 cm, weight 433 g

Condition: Good; hardly legible engravings. Similar to the previous bowl, no. 17, traces of corrosion on the outer and inner surfaces. Some cracks on the outer bottom.

Decorative Patterns

Exterior: Devoid of decoration.

Interior: Concentric bands, with the main one on the wall enclosing four oval cartouches alternated with four small circular medallions. A large circular medallion on the bottom encloses a cubic building (*turba*) with an oval dome and two lateral minarets (Fig. 1).

Content: No inscription beneath the outer rim. Koranic verses and religious prayers and expressions in Arabic cursive; signature of the artisan or the owner.

Comment: The bowl finds a precise comparison with specimen no. 17. The main differences lie in the representation of the monument that stands out in the centre of the bottom and in the content of some inscriptions. In both cases, the Throne Verse (Kor. 2:255-256), usually found beneath the outer rim, appears beneath the inner rim, leaving the exterior almost entirely without inscriptions.

References: Unpublished.



Fig. 1

No. 19

Inv. No. MO1212 | Aron 270

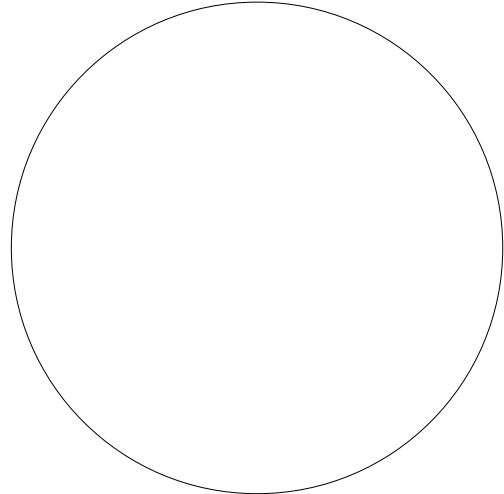
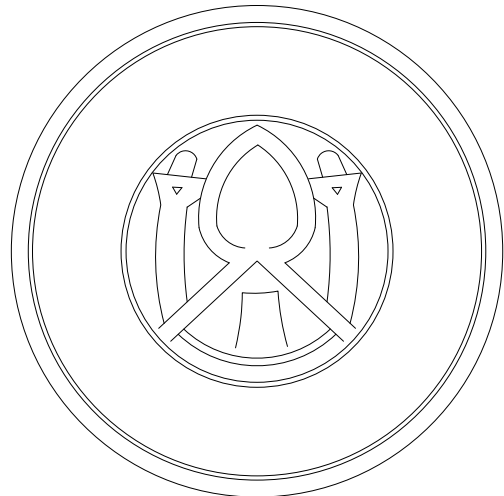
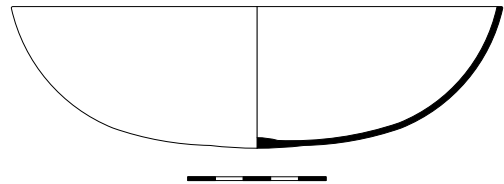
*Exterior**Interior**Profile*

No. 19

Inv. No. MO1212 | Aron 270

Hemispherical bowl with straight rim;
blackish infill in the engraving
Iran, 19th-20th century

Dimensions: diam. 17.77 cm, h. 5.15 cm, weight 400 g

Condition: Good. The engravings on the inner surface are very hard to read, mainly because they were done with a shallow stroke.

Decorative Patterns

Exterior: Devoid of decoration.

Interior: A large circular medallion on the bottom enclosing a stylised cubic building (*turba*) with an oval dome and two lateral minarets (Fig. 1).

Content: No inscription beneath the outer rim. Koranic verses and religious expressions in Arabic cursive; isolated Arabic letters and numbers; signature of the artisan or the owner.

Comment: The bowl is compared with the two previous specimens (nos. 17 and 18), from which it differs in the quality of the engravings, the content of the texts, and the graphic representation of the building on the inner bottom. Furthermore, only in this case is an Arabic inscription engraved inside the dome.

References: Unpublished.



Fig. 1

No. 20

Inv. No. MO1168 | Aron 260

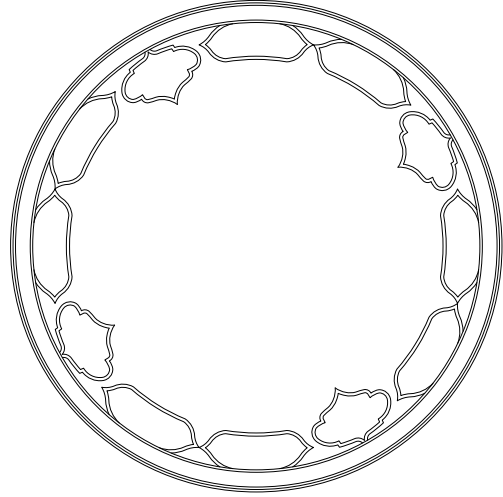
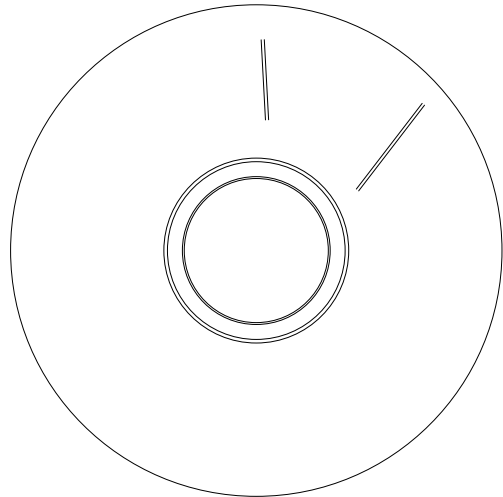
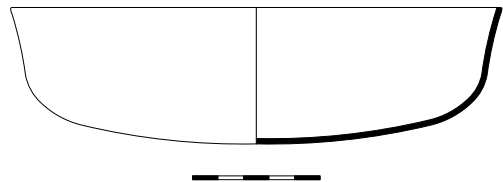
*Exterior**Interior**Profile*

No. 20

Inv. No. MO1168 | Aron 260

Hemispherical bowl with rounded rim;
black infill in the engravings
Iran, 17th century

Dimensions: diam. 19.28 cm, h. 5.35 cm, weight 445.8 g

Condition: Fair; a crack runs through the wall and part of the bottom. Sporadic corrosion on both outer and inner surfaces.

Decorative Patterns

Exterior: A band composed of four pairs of rectangular cartouches with pointed short sides, alternated with four polylobed cartouches. All the cartouches are outlined by two thin parallel lines.

Interior: A circular medallion on the bottom.

Content: Religious formula referring to the first four Caliphs, in cursive Persian, beneath the outer rim. Koranic verses and religious expressions in Arabic cursive.

Comment: The bowl features inscriptions, concentrated mainly on the inner wall, where they are arranged in concentric lines. The letters are small in size, except for those in the inscription beneath the outer rim and those forming the “testimony of faith” (*shahāda*) enclosed within the central medallion on the interior (Fig. 1). In both cases, the letters stand out against a background filled with short oblique strokes.

References: Unpublished.



Fig. 1

No. 21

Inv. No. MO1169 | Aron 122



Exterior

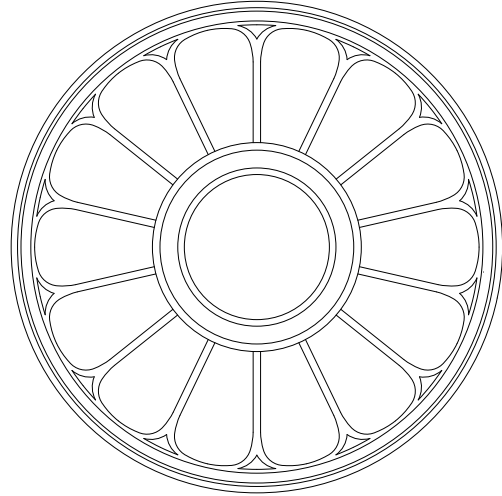

Interior

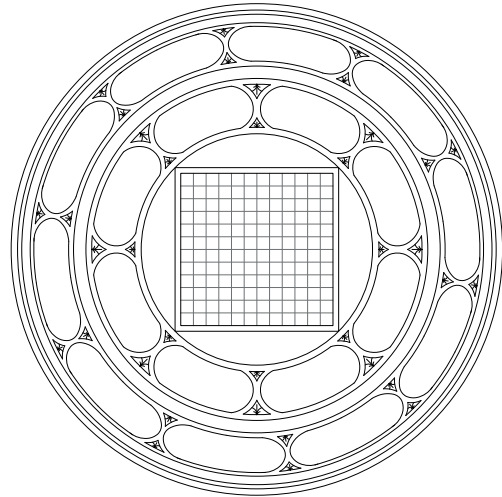

Profile

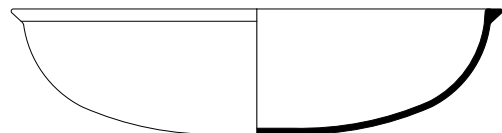

No. 21

Inv. No. MO1169 | Aron 122

Hemispherical bowl with a flat, slightly everted rim;
black infill in the engravings
Anatolia or north Jazira, 14th-15th century

Dimensions: diam. 20.61 cm, h. 5.25 cm, weight 584 g

Condition: Fair; infill largely lost.

Decorative Patterns

Exterior: A 14-petal flower arranged around a circular medallion that stands out on the bottom.

Interior: Two concentric bands, each composed of 10 and eight oval cartouches. A square grid on the bottom.

Content: Kor. 1 and religious formulas in Arabic cursive beneath the outer rim. Koranic verses and religious expressions in Arabic cursive; Arabic and non-Arabic magical characters in Kufic script; sequences of Arabic numbers; some of the 99 “Beautiful Names” of God; the names of the 12 zodiac signs; a 12×12 numeric magic square (Fig. 1).

Comment: The names of the zodiac signs and two of the 99 Names of God are enclosed in the 14 remaining triangular spaces between the petals of the flower on the inner wall. The numerical sequences, which are particularly numerous, appear both inside the cartouches and above and below the rim. In the 12×12 magic square, composed of two- or three-digit numbers, the number 4 is rendered in the Persian style, while the number 5 has an oval shape. The decorative pattern is meticulously executed, whereas the style of the cursive script is somewhat unrefined.

References: Unpublished.



Fig. 1

No. 22

Inv. No. MO1166 | Aron 258

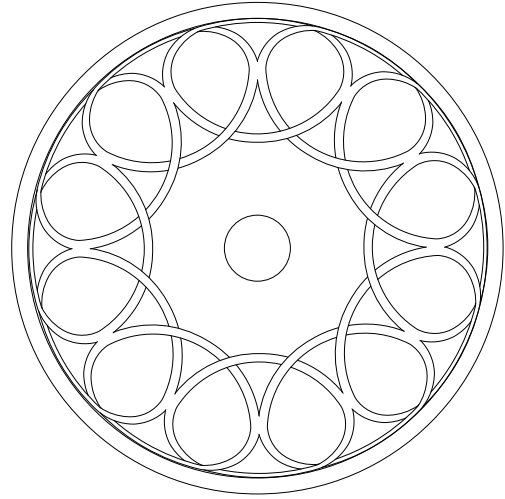
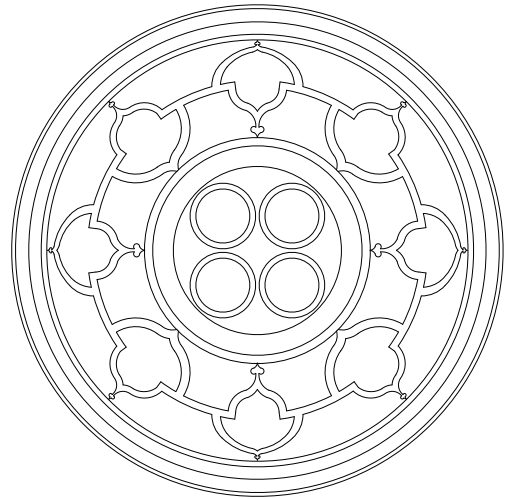
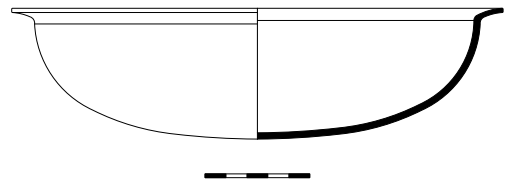
*Exterior**Interior**Profile*

No. 22

Inv. No. MO1166 | Aron 258

Hemispherical bowl with slightly flared rim;
black infill in the engravings
Iran, 16th century

Dimensions: diam. 23.49 cm, h. 6.25 cm, weight 540 g

Condition: Fair; traces of oxidation both on the exterior and interior. The infill is partially faded.

Decorative Patterns

Exterior: Two overlapping and offset sequences of circles, generating 12 oval elements, shaped like flower petals. The motif is traced by a narrow ribbon, skilfully winding in and out, so as to produce a chain without beginning or end.

Interior: Uninterrupted sequence of polylobed cartouches on the wall (Fig. 1); on the bottom, a circular medallion encloses four identical and equidistant roundels.

Content: No inscription beneath the outer rim. Koranic verses and religious expressions in Arabic cursive; Arabic and non-Arabic magical characters in Kufic script, mainly concentrated in the four roundels that decorate the inner bottom.

Comment: The Throne Verse (Kor. 2:255-256) appears on the upper surface of the rim, rather than on the outer wall beneath the rim. All other inscriptions are found inside and outside the cartouches. More or less extensive portions of white/silver color remain on the upper part of both the outer and inner surfaces. For this feature, see also bowl no. 24.

References: Unpublished.



Fig. 1

No. 23

Inv. No. MO1171 | Aron 437

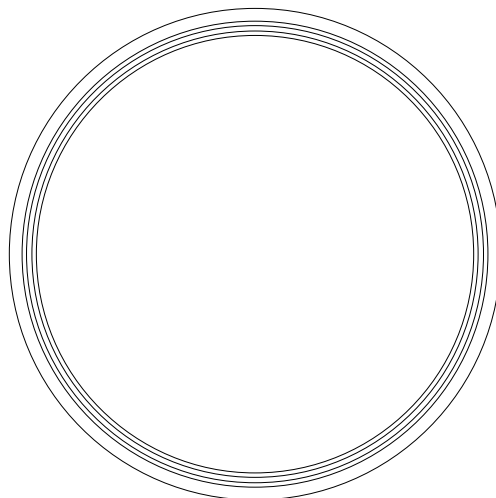
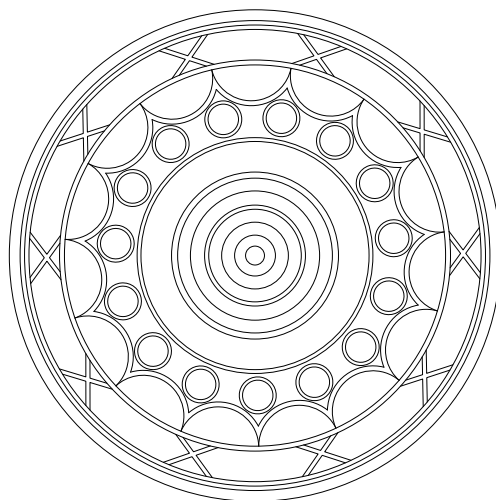
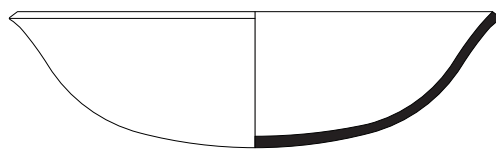
*Exterior**Interior**Profile*

No. 23

Inv. No. MO1171 | Aron 437

Large hemispherical bowl with rounded and slightly flared rim;
black infill in the engravings
Iran, 18th century

Dimensions: diam. 33.3 cm, h. 9.5 cm

Condition: Good; sporadic smudges of black infill on the inner surface (Fig. 1).

Decorative Patterns

Exterior: Devoid of decoration.

Interior: Concentric bands: the one below the rim encloses a sequence of long hexagonal cartouches, while the one on the wall features a continuous sequence of 15 semicircles and an equal number of small circular medallions.

Content: No inscription beneath the outer rim. Koranic verses, religious prayers and expressions, and some of the 99 “Beautiful Names” of God in Arabic cursive.

Comment: The bowl does not have exact parallels within the collection or among other known examples. However, the content of the inscriptions and the “Beautiful Names” of God enclosed in the small circular medallions on the inner wall can also be found on many magic bowls. The infill inside the engravings, both for the frames and the script, is very thick and causes, in many cases, more or less noticeable smudging.

References: Unpublished.



Fig. 1

No. 24

Inv. No. MO1178 | Aron 259

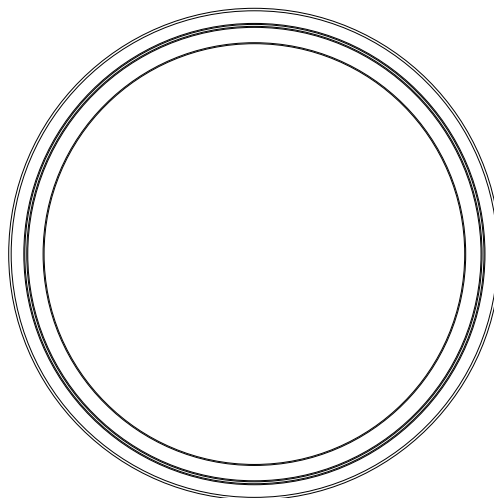
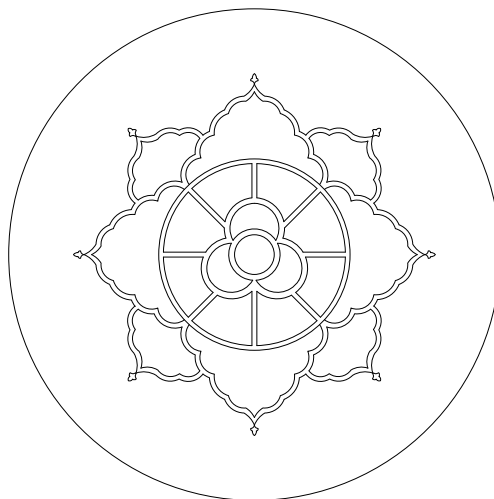
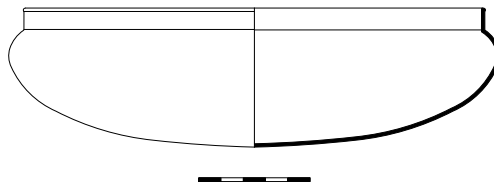
*Exterior**Interior**Profile*

No. 24

Inv. No. MO1178 | Aron 259

Hemispherical bowl with a vertical rim with rounded lip;
black infill in the engravings
Iran, 16th century

Dimensions: diam. 22.1 cm, h. 6.25 cm, weight 526 g

Condition: Good; many traces of oxidation.

Decorative Patterns

Exterior: Concentric bands.

Interior: A six-petaled vegetal element arranged around a circular medallion divided into eight sections, which in turn contains a sort of trilobed flower.

Content: Koranic verses and religious expressions in Arabic cursive.

Comment: The shape of the bowl is quite unusual, both in terms of the profile of the walls and the rim, as well as the deep horizontal grooves on the exterior. The trilobed, flower-shaped termination of the petals of the vegetal element on the inner bottom is similar to those of specimens no. 15 (on both the outer and inner surfaces) and, especially, to the inner surface of bowl no. 22, for which the same dating and production area are suggested. It is interesting to note that, as with bowl no. 22, there are prominent traces of white/silver color in the bands running below the outer rim and along the contours of the inner cartouches (Fig. 1). The cursive script, executed in small characters, is particularly precise.

References: Unpublished.



Fig. 1

No. 25

Inv. No. MO1140 | Aron 224

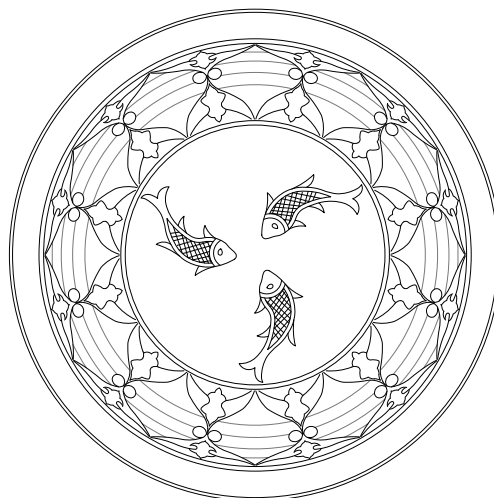
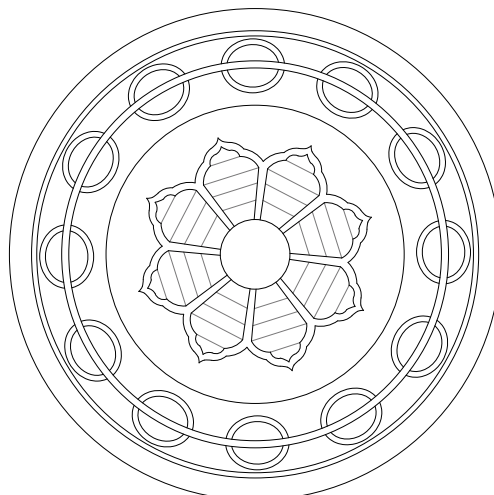
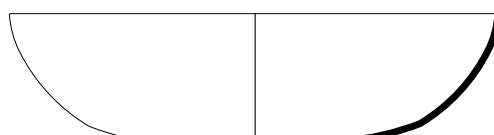
*Exterior**Interior**Profile*

No. 25

Inv. No. MO1140 | Aron 224

Hemispherical bowl with straight rim; silver inlay;
whitish infill in the engravings
Syria or Mesopotamia, 14th-15th century

Dimensions: diam. 15.05 cm, h. 4.09 cm, weight 318.5 g

Condition: Fair; particularly fine engravings, with the infill largely lost and almost completely disappeared on the outer and inner bottom.

Decorative Patterns

Exterior: A sequence of vegetal-type medallions on the wall; three fish in a circle, facing toward the centre, on the bottom (Fig. 1).

Interior: Two parallel bands on the wall, the lower one adorned with a sequence of 12 equidistant roundels. An eight-petal flower on the bottom.

Content: Inscription containing God's blessings on "The Fourteen Infallibles" (*Chahārdah ma' šūm*) in Arabic cursive beneath the outer rim. Koranic verses, religious formulas, groups of letters and numbers.

Comment: The ornamental band on the outer wall is not found on other known specimens. The same applies to the three fish arranged in a circle on the bottom, although this motif is particularly widespread in medieval Islamic metalwork. In this case, a diagonal lattice grid adorns the body of each fish. The vegetal element that stands out on the bottom, however, is very common on magical bowls. Due to the type of engraving, much of the decoration and the inscriptions are poorly legible.

References: Unpublished.



Fig. 1

No. 26

Inv. No. MO1213 | Aron 228

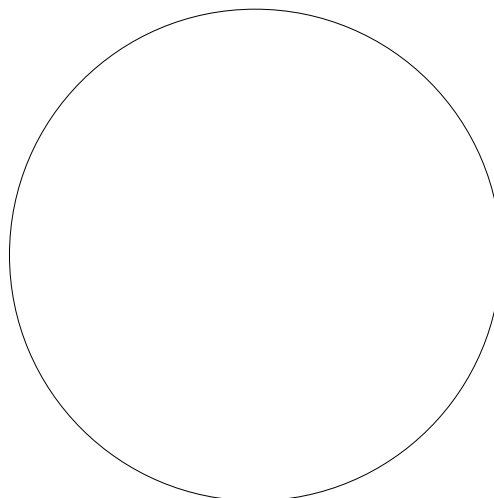
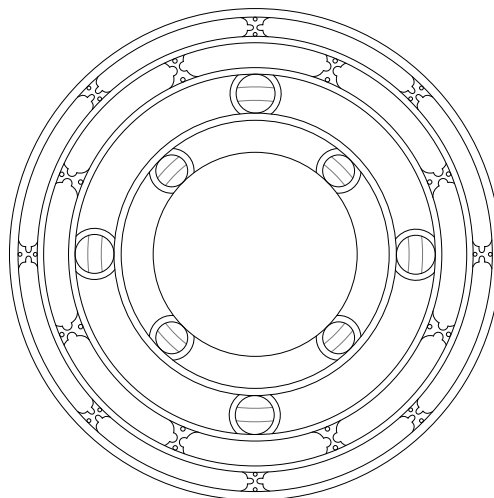
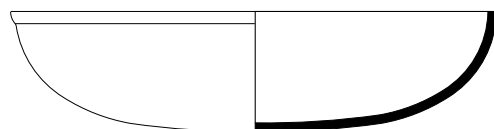
*Exterior**Interior**Profile*

No. 26

Inv. No. MO1213 | Aron 228

Hemispherical bowl with slightly rounded rim;
black infill in the engravings
Iran, 16th-17th century

Dimensions: diam. 17.08 cm, h. 4.17 cm, weight 417.4 g

Condition: Fair; very worn engravings, some of which are illegible.

Decorative Patterns

Exterior: Devoid of decoration.

Interior: A series of concentric bands on the wall; the two upper bands enclose eight rectangular cartouches with trilobed side terminations; the two lower bands enclose four small, equidistant circles.

Content: No inscription beneath the outer rim. Koranic verses and religious expressions in Arabic cursive; Arabic and non-Arabic magical characters; Arabic numbers (Figs. 1, 2).

Comment: The slight, thin, concentric and horizontal grooves on the outer wall are not commonly found in this class of objects. See, for instance, bowl no. 24. Despite the poor accuracy of the engravings, the “hourglass” motif (Fig. 3) created by the arrangement of the cartouches in the two upper bands of the inner wall is notable. Similar motifs, though more refined, are frequently found on Safavid metalwork artefacts (see also bowl no. 27).

References: Unpublished.



Fig. 1



Fig. 2



Fig. 3

No. 27

Inv. No. MO1217 | Aron 321

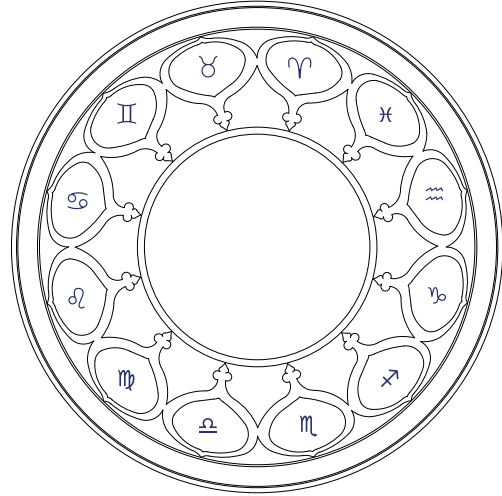
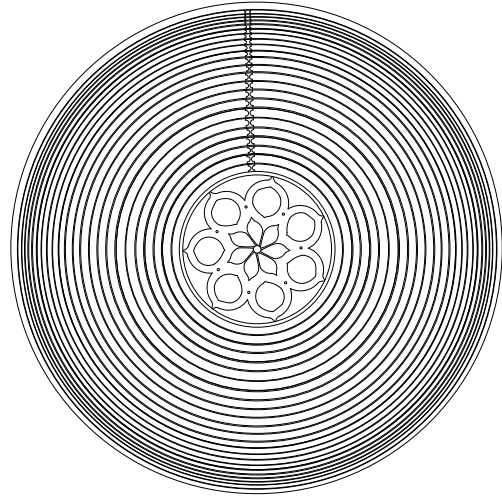
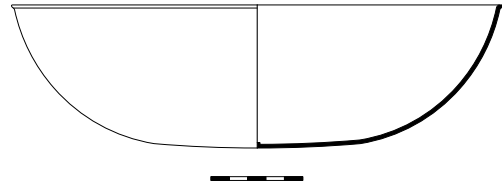
*Exterior**Interior**Profile*

No. 27

Inv. No. MO1217 | Aron 321

Large hemispherical bowl with a rounded rim;
niello and black infill in the engravings
Iran, 1085/1674-75

Dimensions: diam. 26.8 cm, h. 7.8 cm, weight 462 g

Condition: Fair. Some patches and soldering marks on the wall; infill partially lost; extensive corrosion on both the outer and inner surfaces.

Decorative Patterns

Exterior: 12 oval medallions with a lower termination in the shape of a trilobed flower; circular medallion on the bottom.

Interior: A series of 25 concentric lines on the wall and the bottom; at the center of the bottom, a circular medallion encloses a double six-petaled flower (Fig. 1); the 12 zodiac signs in clockwise order.

Content: Inscription containing God's blessings on "The Fourteen Infallibles" (*Chahārdah ma'sūm*) in Arabic cursive beneath the outer rim. Full text of the Shi'i prayer *Jawshan al-Kabīr* ("The Greater Armor"); sequences of isolated numbers; 12 zodiac signs.

Comment: The 25 concentric lines on the interior are each underlined by a double engraved line. An "hourglass" motif is formed between the beginning and end of each cartouche (Fig. 2). The script, with the exception of that on the outer band and the six petals of the flower on the interior, is in small, particularly refined characters. An important detail is the presence of the date of manufacture, 1085 of the Hijra (1674–75), which runs beneath the outer rim, at the end of the prayer. The bowl also features one of the few examples of the entire text of the *Jawshan al-Kabīr* on metalwork, one of the most important Shi'i prayers, attributed to the Prophet Muhammad. For the "hourglass" motif between the epigraphic cartouches on the inner surface, typical of the Safavid period, see also bowl no. 26.



Fig. 1 *References:* Bernardini in press.



Fig. 2

No. 28

Inv. No. MO1177 | Aron 214



Exterior

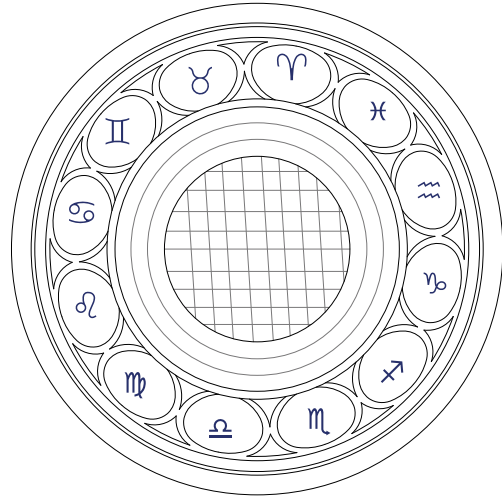

Interior

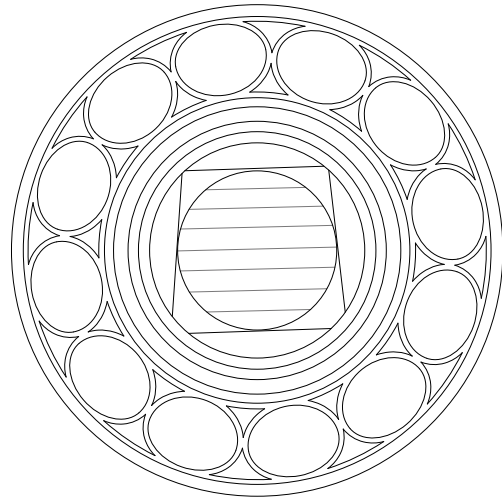

Profile

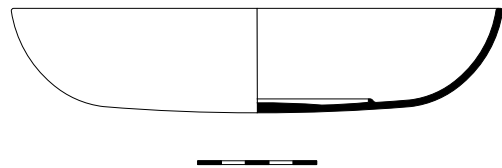

No. 28

Inv. No. MO1177 | Aron 214

Bowl with a flat base, curved wall, and flat rim;
blackish infill in the engravings
Iran, 16th-17th century

Dimensions: diam. 20.66 cm, h. 4.39 cm, weight 635 g

Condition: Good; infill largely lost on the outer and inner bottom.

Decorative Patterns

Exterior: On the wall, 12 circular medallions, generated by continuous ribbons. A magic grid on the bottom, within three concentric circles.

Interior: On the wall, the same decorative pattern as the exterior; at the center of the bottom, an epigraphic medallion enclosed within an irregular rectangular frame.

Content: Inscription containing God's blessings on "The Fourteen Infallibles" (*Chahārdah ma'sūm*) in Arabic cursive beneath the outer rim. Koranic verses and religious prayers and expressions in Arabic cursive; magical alphabetical grid; 12 zodiac signs in counterclockwise order (Annex II).

Comment: A close similarity is observed between the decorative pattern on the exterior and that on the interior, except for the motif that stands out at the center of the outer and inner bottom. The medallions on the exterior enclose the zodiac signs (Fig. 1), while those on the interior contain religious formulas (Fig. 2). Each zodiac sign, enclosed within a circular medallion, stands out against a background filled with vegetal scrolls, as seen on the previous specimen (no. 27).

References: Unpublished.

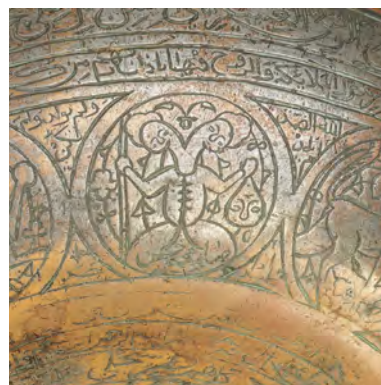

Fig. 1



Fig. 2

No. 29

Inv. No. MO1221 | Aron 140

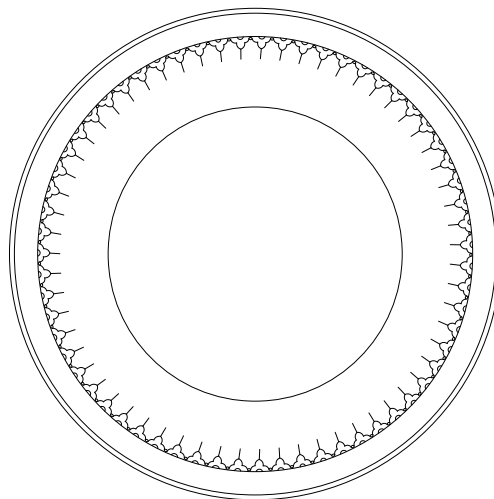
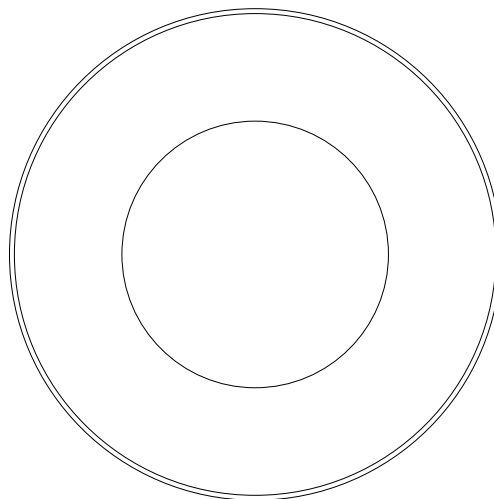
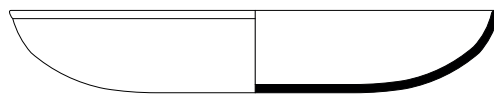
*Exterior**Interior**Profile*

No. 29

Inv. No. MO1221 | Aron 140

Shallow bowl with a flat base, curved wall, and a flat rim;
black infill in the engravings
Iran, 17th-18th century

Dimensions: diam. 17.91 cm, h. 3 cm, weight 511 g

Condition: Good. The infill in the engravings on the inner surface are almost completely worn off, especially on the bottom.

Decorative Patterns

Exterior: A wide band at the upper part of the wall, supported by a sequence of small arches with four concave lobes. Each arch is topped with a small globe (Fig. 1).

Interior: Devoid of decoration.

Content: Kor. 36:77-83 (followed by the expression “O Allah, it is death to the infidels!”), Kor. 2:255-256 (the so-called “Throne Verse”), Kor. 112, Kor. 113, and Kor. 114 (the so-called al-Mu’awwidhāt - The Protective Surahs) beneath the outer rim. Kor. 36:1-70 in the interior.

Comment: Except for the sequence of arches on the outer wall, the bowl features only cursive Arabic inscriptions, arranged in concentric horizontal lines. The texts are entirely based on Koranic verses, particularly the Surah Yā-Sīn, which begins and unfolds across the entire inner surface and ends on the outer surface. This Surah, as well as the others present on the bowl, is considered particularly effective in magical contexts. Equally potent seems to be the curse formula directed against the infidels (*yā Allāh al-mawt ‘alā-l-kāfirīn*), which concludes the first line of the external inscription. The morphology of the object, the distribution of the texts, and the style of the script suggest that it is a product from the Iranian territories during the Safavid period, likely from the 17th–18th centuries.

References: Unpublished.



Fig. 1

No. 30

Inv. No. MO1176 | Aron 392

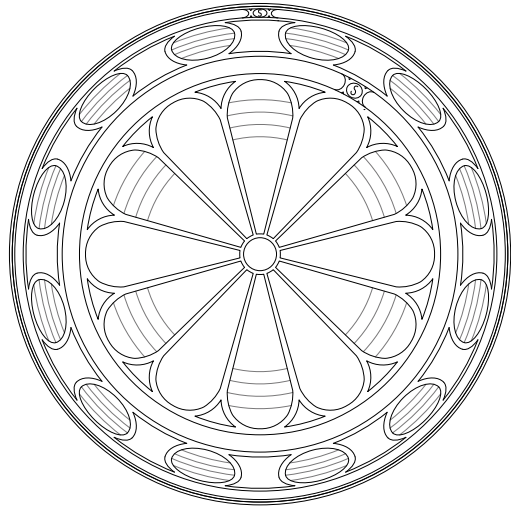
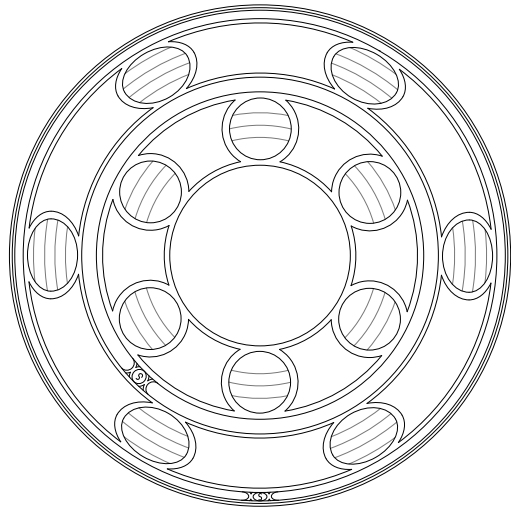
*Exterior**Interior**Profile*

No. 30

Inv. No. MO1176 | Aron 392

Shallow bowl with a flat base, curved wall, and flat rim;
black infill in the engravings
Iran, 16th century

Dimensions: diam. 19.59 cm, h. 4.7 cm

Condition: Fair; sporadic tail-like stains from the dripping of the infill. Traces of oxidation. Small suspension hole on the wall.

Decorative Patterns

Exterior: On the wall, a band with 10 roundels, identical and equidistant; a 10-petaled flower on the bottom.

Interior: Concentric bands, the two main ones each including six roundels. Circular medallion on the bottom.

Content: Koranic verses and religious expressions in Arabic cursive; Arabic and non-Arabic magical characters in cursive; numbers both isolated and in sequence (Fig. 1-2).

Comment: The bowl is notable for the two refined patterns on the exterior and interior, but the writing is very clumsy, especially the inscription enclosed in the medallion that stands out on the inner bottom. The vegetal motif on the outer bottom is similar to the one engraved on the exterior of bowl no. 21, which can be dated to an earlier period. For the numerous smudges, visible both on the exterior and interior and caused by the thickness of the black infill, see also bowl no. 23.

References: Unpublished.



Fig. 1



Fig. 2

No. 31

Inv. No. MO1216 | Aron 393

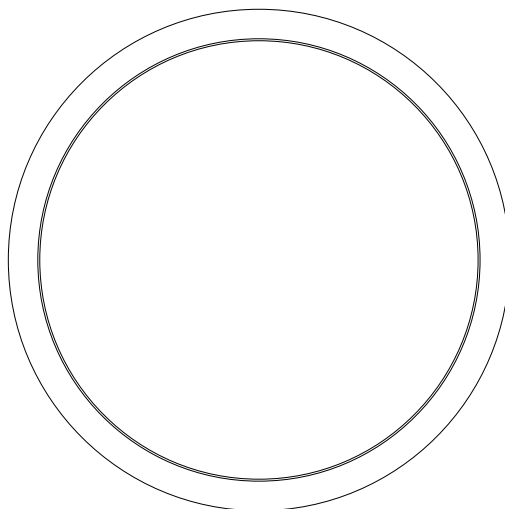
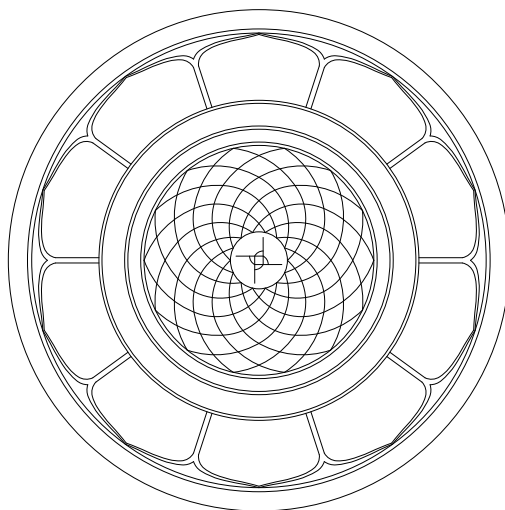
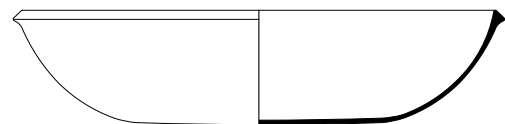
*Exterior**Interior**Profile*

No. 31

Inv. No. MO1216 | Aron 393

Shallow bowl with a flat base, curved wall, and slightly flared rim;
 black infill in the engravings
 Iran, 17th-18th century

Dimensions: diam. 27.48 cm, h. 6.4 cm

Condition: Good.

Decorative Patterns

Exterior: Epigraphic band on the wall, beneath the rim.

Interior: A sequence of 10 cartouches in the shape of petals arranged around a large circular medallion occupying the bottom. The medallion is decorated with a kind of kaleidoscope grid.

Content: Religious formula beneath the outer rim. Koranic verses and religious expressions in Arabic Kufic and cursive; 99 “Beautiful Names” of God.

Comment: The bowl is very refined, both in its decorative patterns and writing styles. The infill within the larger letters consists of a dark composition, similar to niello. The Kufic script is strongly inspired by the Kufic with triangular apices typical of the 10th–12th centuries and is very rarely found on this class of magical objects. In the two main Kufic inscriptions—one beneath the outer rim and the other around the medallion on the inner bottom—each word is repeated twice, on two different levels and with two different thicknesses, a solution that gives greater harmony to the epigraphic bands. The small medallion at the centre of the inner bottom features a sort of knot that divides the space into four quadrants: in each quadrant, the name of God (*Allāh*) is inscribed (Fig. 1).

References: Unpublished.



Fig. 1

No. 32

Inv. No. MO1153 | Aron 180

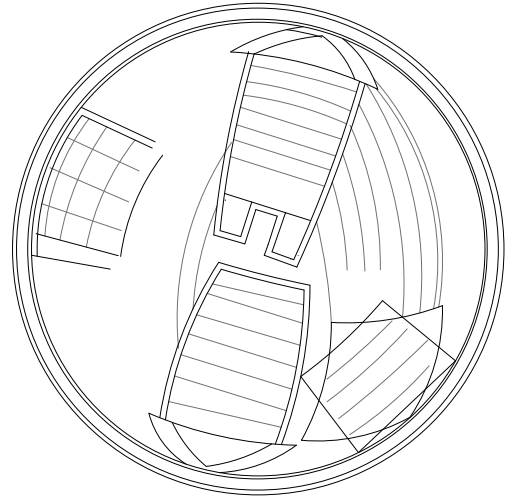
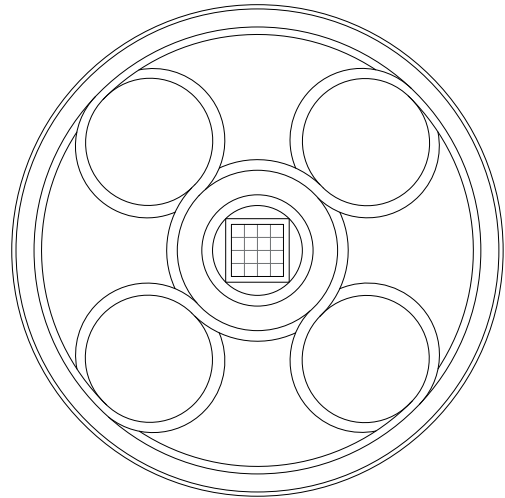
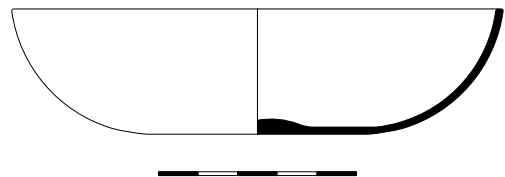
*Exterior**Interior**Profile*

No. 32

Inv. No. MO1153 | Aron 180

Shallow bowl with a flat base and slight internal bulge, curved wall, and straight rim; black infill in the engravings
 Syria or Jazira, 15th-16th century

Dimensions: diam. 12.44 cm, h. 3.17 cm, weight 211 g

Condition: Good; the infill has been lost, especially on the outer and inner bottom.

Decorative Patterns

Exterior: Asymmetric distribution of frames and cartouches of varying shapes and sizes.

Interior: Five circular medallions, outlined by crossed ribbons: four medallions on the wall, one in the centre of the bottom. The latter contains a magic square.

Content: Koranic verses and religious expressions in Arabic cursive; Arabic and non-Arabic magical characters in Kufic script; sequences of isolated letters and numbers (Fig. 1); two 4×4 numeric magic squares.

Comment: The main features of this bowl lie in the absence of a symmetrical decorative pattern on the outer wall and the lack of incised lines separating the rows, both on the exterior and the interior. Additionally, the epigraphic band running beneath the outer rim is divided into sections by vertical segments. The magic square on the exterior strangely consists of numbers made up of both one- and two-digit figures (Fig. 2). As in numerous examples, the number 4 is transcribed in the Persian style. The arrangement of the four circular medallions on the inner bottom, placed around a square cartouche, is also found on bowl no. 4, dated to the late 13th century. For the four medallions on the inner bottom arranged around a cartouche, see also bowls no. 4 and 5.

References: Unpublished.



Fig. 1



Fig. 2

No. 33

Inv. No. MO1214 | Aron 209

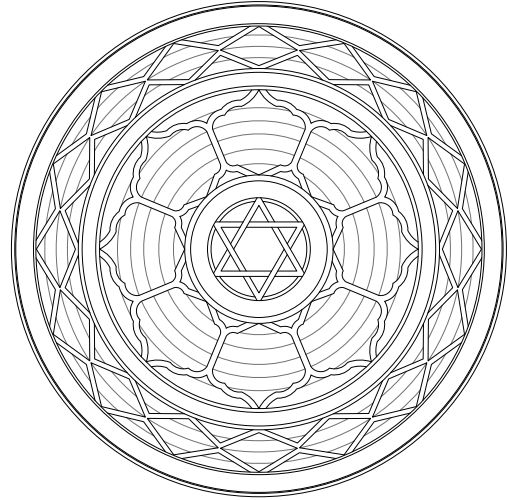
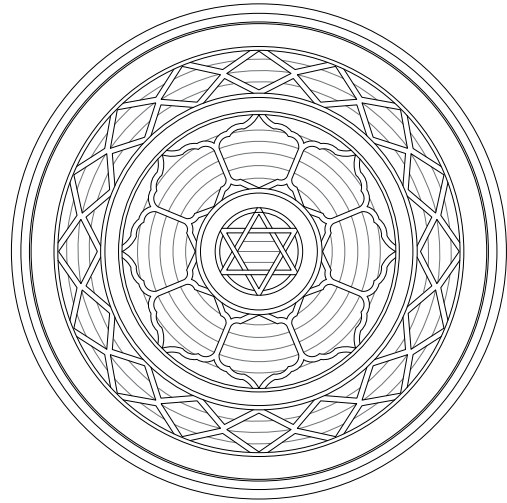
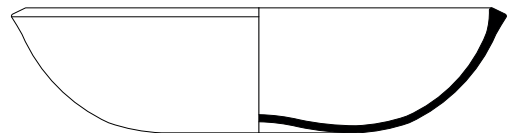
*Exterior**Interior**Profile*

No. 33

Inv. No. MO1214 | Aron 209

Bowl with a flat base and slight internal bulge, curved wall, and flat and slightly slanted rim; blackish infill in the engravings
India, Rajasthan, second half of the 18th century

Dimensions: diam. 21 cm, h. 5.3 cm, weight 711 g

Condition: Good.

Decorative Patterns

Exterior: Concentric bands: the one on the central part of the wall encloses a geometric chain of rhomboidal elements traced by a narrow ribbon, skilfully winding in and out; the one around the bottom is adorned with eight polylobed cartouches, distributed around a central medallion, resembling flower petals. In the center of the circular medallion, a six-pointed star is formed by the intersection of two triangles (Fig. 1).

Interior: Identical to the exterior.

Content: Kor. 2:255-256 (the Throne Verse) beneath the outer rim. Other Koranic verses and religious expressions in Arabic cursive; isolated Arabic letters and numbers.

Comment: The repetition of the same decorative pattern on both the outer and inner surfaces is uncommon, although it is also found on bowl no. 15. Similarly rare is the repetition of the Throne Verse in the two bands running beneath the outer and inner rims, respectively. The cursive script in these two bands features large characters. The bowl is of Indian production and can be dated to the second half of the 18th century. In the band beneath the inner rim, after a Koranic verse, there is a four-digit number, 1199 (Fig. 2), which could refer to the object's date of manufacture according to the Hijri calendar. This would correspond to the year 1784.

References: Unpublished.



Fig. 1



Fig. 2

No. 34

Inv. No. MO1167 | Aron 276

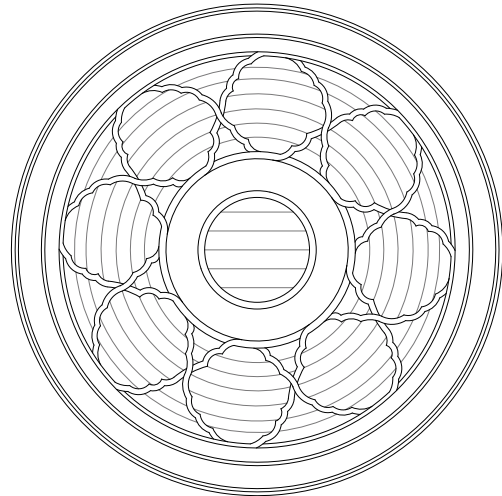
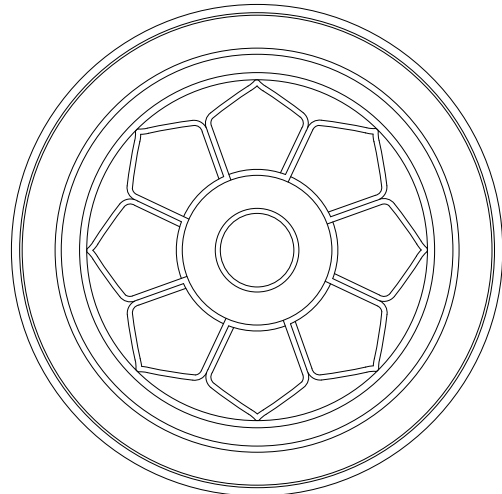
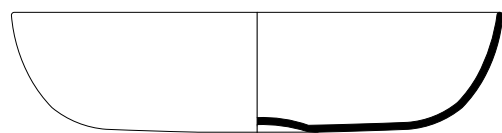
*Exterior**Interior**Profile*

No. 34

Inv. No. MO1167 | Aron 276

Bowl with a flat base and slight internal bulge,
curved wall, and straight rim; black infill in the engravings
India, 18th century

Dimensions: diam. 21.2 cm, h. 5.17 cm, weight 750 g

Condition: Good; a slight crack on the outer bottom.

Decorative Patterns

Exterior: A large band decorated with eight polylobed cartouches formed by a narrow ribbon, skillfully winding in and out, so as to produce a chain with no beginning or end. A circular medallion stands out in the centre (Fig. 1).

Interior: Two concentric bands on the upper part of the wall, an eight-lobed flower around the bottom, a circular medallion in the centre (Fig. 2).

Content: The Throne Verse (Kor. 2:255-256) in Arabic cursive beneath the outer rim. Other Koranic verses and religious expressions in Arabic cursive; isolated Arabic letters.

Comment: The outer and inner surfaces of the bowl, as with other examples, are completely covered with inscriptions, mostly of Koranic content. Another characteristic lies in the varying sizes of the script, which, in turn, is underlined by horizontal lines only in the inscriptions distributed on the outer surface.

References: Unpublished.



Fig. 1



Fig. 2

No. 35

Inv. No. MO1220 | Aron 271

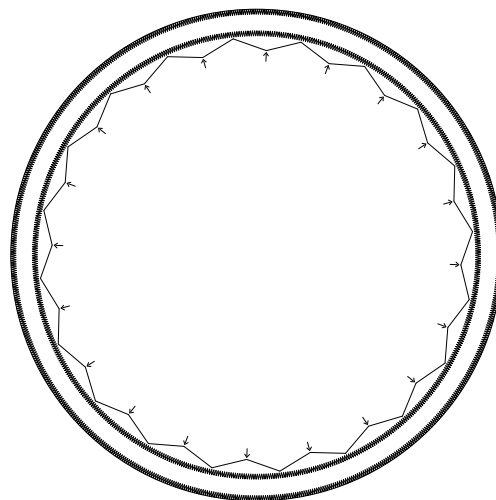
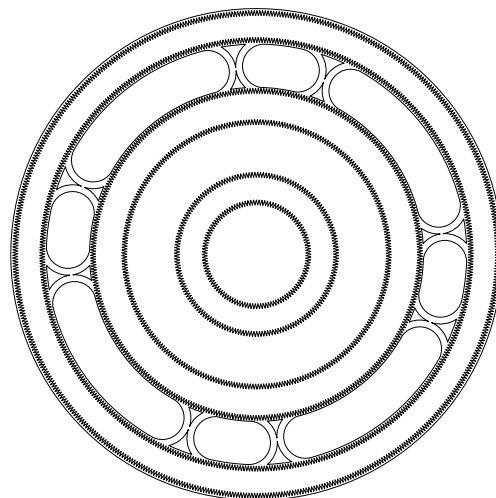
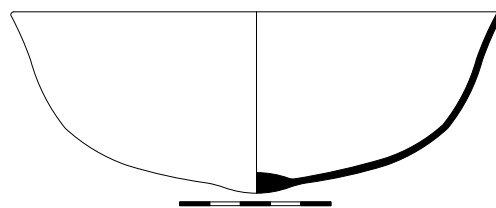
*Exterior**Interior**Profile*

No. 35

Inv. No. MO1220 | Aron 271

Bowl with a slightly pointed base, curved wall, and straight rim;
white/yellow infill in the engravings
Iran, 19th century

Dimensions: diam. 16.26 cm, h. 6 cm, weight 366.3 g

Condition: Fair; highly oxidised. A deep crack between the base and the wall, roughly restored.

Decorative Patterns

Exterior: A double register on the upper part of the wall: the upper register features an epigraphic band, while the lower register consists of a continuous sequence of arches supported by a series of upward-pointing arrows (Fig. 1).

Interior: Concentric bands, with the main one on the wall enclosing four oval cartouches alternated with four small circular medallions. A large circular medallion on the bottom.

Content: Throne Verse (Kor. 2:255-256) in Arabic cursive beneath the inner rim. Other Koranic verses and religious expressions in Arabic cursive. Invocation for 'Alī, *Nādi 'Aliyyan* ("Call upon 'Alī").

Comment: For the distribution and shape of the cartouches on the inner surface, as well as for the style of the cursive script, this specimen can be compared with bowls nos. 17 and 18, from which it differs by the absence of the building that decorates the bottom of these bowls. The invocation in honor of 'Alī, cousin and son-in-law of the Prophet, as well as the last of the Rightly Guided Caliphs, is very common on bowls featuring a central umbo and is generally placed on the bottom around the umbo.

References: Unpublished.



Fig. 1

No. 36

Inv. No. MO1215 | Aron 266

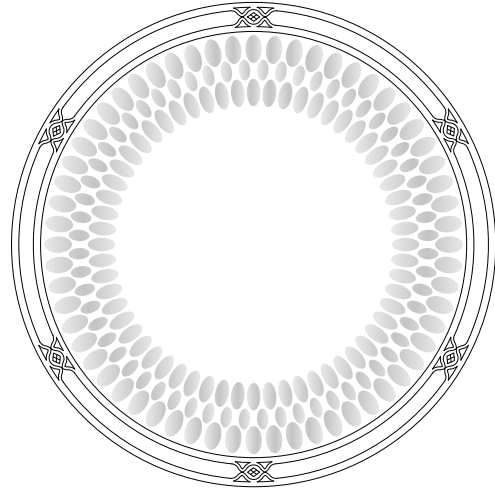
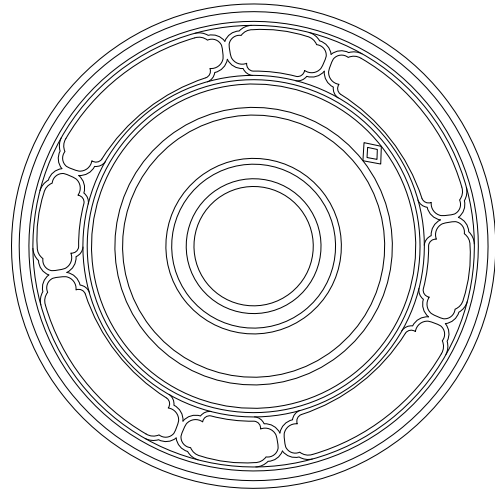
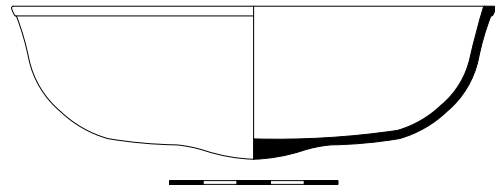
*Exterior**Interior**Profile*

No. 36

Inv. No. MO1215 | Aron 266

Bowl with a slightly pointed base, curved wall, and flat rim
Turkey or Iran, 18th-19th century

Dimensions: diam. 14.4 cm, h. 4.55 cm, weight 250.7 g

Condition: Good; small fracture on the rim.

Decorative Patterns

Exterior: Below the rim, a sequence of six rectangular cartouches separated by a geometric element; on the wall, concentric horizontal sequences of oval-shaped grooves.

Interior: A series of concentric bands, with the uppermost divided into eight cartouches. A circular medallion on the bottom.

Content: Prayers and religious expressions in cursive Arabic; *Chahārdah ma'ṣūm* (God's blessings on "The Fourteen Infallibles"); Koranic verses; name of the owner. In the central medallion, the names of Allāh, Muḥammad, 'Alī, Fāṭima, Ḥasan, and Ḥusayn (Fig. 1).

Comment: In terms of shape, the bowl is comparable to the previous specimen (no. 35); however, regarding the arrangement of the inscriptions on the inner surface, the bowl is more similar to specimens no. 17 and 18. In this case, however, the depiction of the building is replaced by the names of God, the Prophet, 'Alī, his wife Fāṭima, and their two sons Ḥasan and Ḥusayn, names that are frequently attested on Shi'ī magic bowls (see also bowl no. 39).

References: Unpublished.



Fig. 1

No. 37

Inv. No. MO1165 | Aron 282

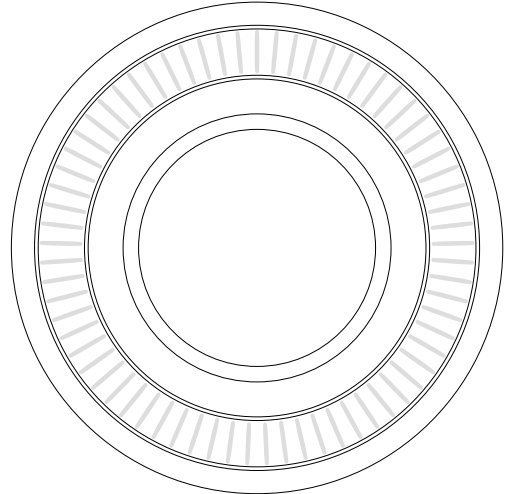
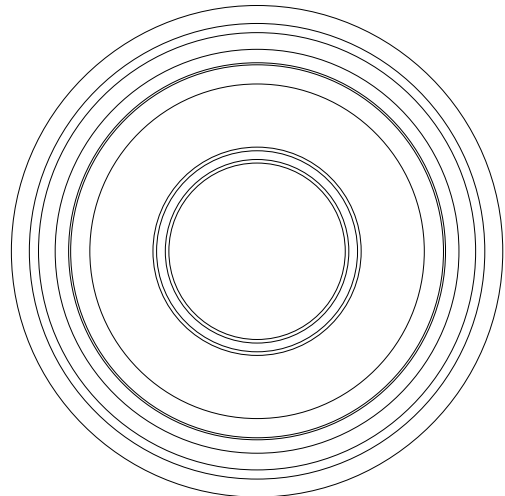
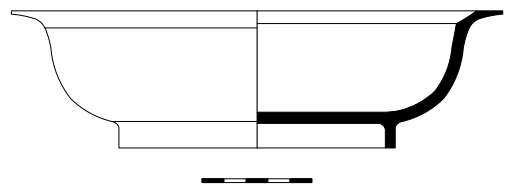
*Exterior**Interior**Profile*

No. 37

Inv. No. MO1165 | Aron 282

Bowl with a flat base on a ring foot, curved wall, and flared rim;
white/yellow infill in engravings
India?, 16th-17th century

Dimensions: diam. 22.41 cm, h. 6.25 cm, weight 1156 g

Condition: Good; infill partially lost.

Decorative Patterns

Exterior: Sequence of vertical grooves.

Interior: Concentric bands on the rim and a circular medallion on the bottom.

Content: Koranic verses and religious prayers and expressions in Arabic cursive.

Comment: The bowl, with a ring foot, has a shape similar to that of specimen no. 38, with which it is also compared for the presence of vertical grooves on the outer wall. In the case of this bowl, each groove contains a brief religious expression written from top to bottom in small characters, unfortunately almost illegible towards the lower part of the wall (Fig. 1). The inscriptions on the inner surface are distributed concentrically on the wall and in horizontal lines within the medallion that stands out on the bottom (Fig. 2).

References: Unpublished.



Fig. 1



Fig. 2

No. 38

Inv. No. MO1175 | Aron 297

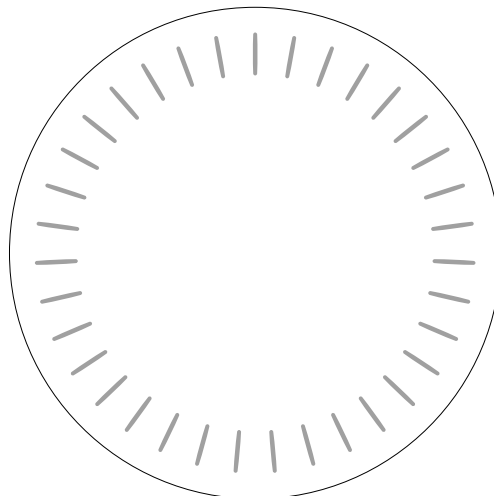
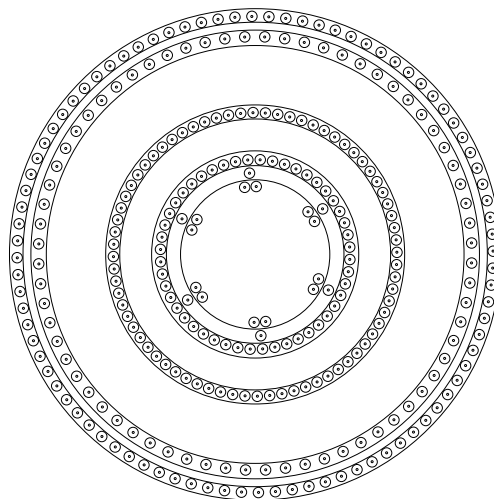
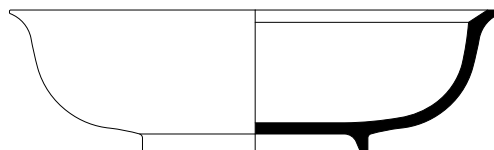
*Exterior**Interior**Profile*

No. 38

Inv. No. MO1175 | Aron 297

Bowl with a flat base on a ring foot, curved wall, and flared rim;
blackish infill in engravings
India?, 16th-17th century

Dimensions: diam. 22.2 cm, h. 6.5 cm, weight 1232 g

Condition: Good; sporadic traces of corrosion and oxidation.

Decorative Patterns

Exterior: Sequence of vertical grooves.

Interior: A series of concentric bands, some of which are filled with sequences of small pierced beads.

Content: Koranic verses and religious expressions in Arabic cursive.

Comment: Beaded bands (Fig. 1) are not frequently attested on this class of objects. Similarly rare is the position of the inscriptions on the inner wall, where the baseline is directed towards the reader (towards the rim rather than towards the bottom). The shape is similar to that of the previous specimen (no. 37), which is also adorned with vertical grooves on the entire outer wall. Form and decoration reveal an Indian production.

References: Unpublished.



Fig. 1

No. 39

Inv. No. MO1219 | Aron 303

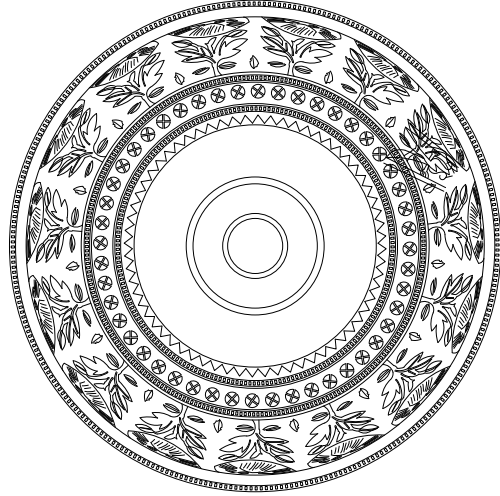
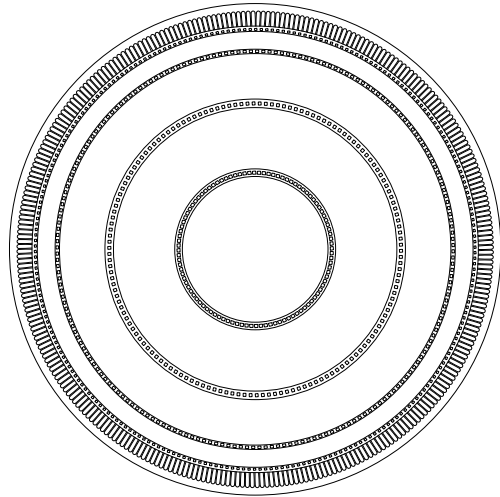
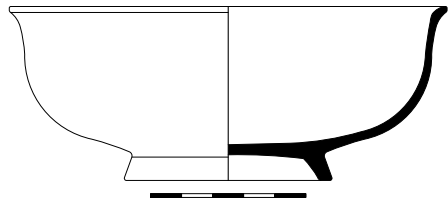
*Exterior**Interior**Profile*

No. 39

Inv. No. MO1219 | Aron 303

Bowl with a flat base on a ring foot, curved wall, and flared rim;
niello and black infill in engravings
India, Deccan, half 19th century

Dimensions: diam. 14.1 cm, h. 5.6 cm, weight 468 g

Condition: Good.

Decorative Patterns

Exterior: A band with a sequence of flowers on the wall, bordered by two strips, each adorned with a sequence of small circular medallions.

Interior: Three concentric bands on the wall, with a circular medallion at the bottom.

Content: Koranic verses and religious expressions in Arabic cursive; names of Allāh, Muḥammad, ‘Alī, Fāṭima, Ḥasan, and Ḥusayn (Fig. 1).

Comment: The bowl is typical of late Indian productions, both in terms of its shape (see also the two previous examples, nos. 37 and 38) and the use of niello, characteristic of the Bidar production, from which the term “Bidri type” or “Bidriware” is derived. Additionally, the flower depicted on the outer wall resembles the Indian poppy (Fig. 2).

References: Unpublished.



Fig. 1



Fig. 2

No. 40

Inv. No. MO1250 | Aron 290

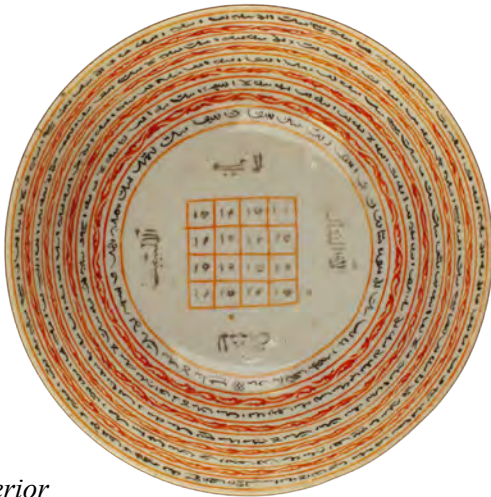
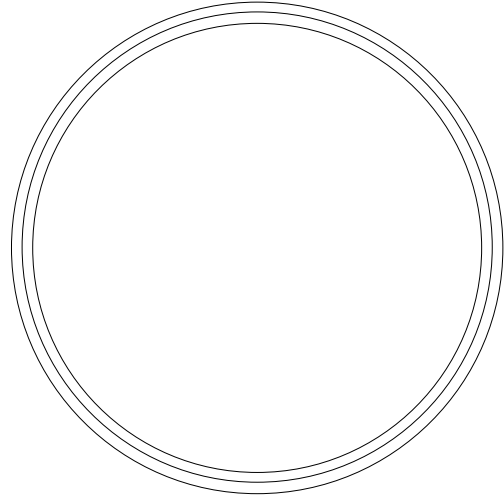
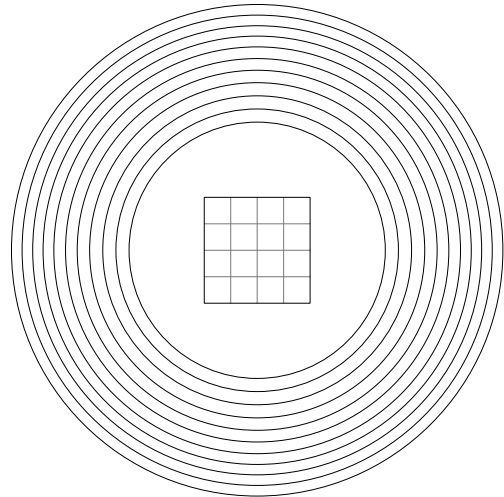
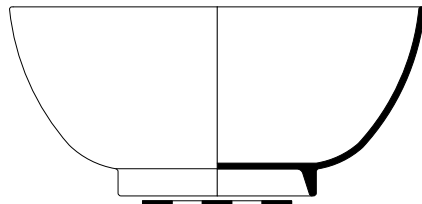
*Exterior**Interior**Profile*

No. 40

Inv. No. MO1250 | Aron 290

Porcelain bowl with a flat base on a ring foot,
curved wall, and straight rim; painted in red and black
China, 18th century

Dimensions: diam. 13.95 cm, h. 6.34 cm, weight 206.8 g

Condition: Good.

Decorative Patterns

Exterior: A horizontal band painted in red beneath the rim, consisting of two parallel lines enclosing a vegetal scroll.

Interior: Nine concentric bands defined by red lines, with five bands featuring black-painted inscriptions alternating with four bands adorned with a red-painted vegetal scroll. A red magic square on the bottom.

Content: Arabic and non-Arabic magical words in cursive script; 4×4 magic square composed of Persian numbers (Fig. 1).

Comment: The collection includes only two magic porcelain bowls, produced in China and mainly exported to Islamic communities in Southeast Asia and India. A considerable number of such bowls are known, dating from the 16th century onwards. Later examples, dating from the 18th century onwards—like the one presented here—are characterised by inscriptions in cursive Arabic script, generally without coherent meaning, and the frequent presence of magic squares. These bowls are generally painted in red and black.

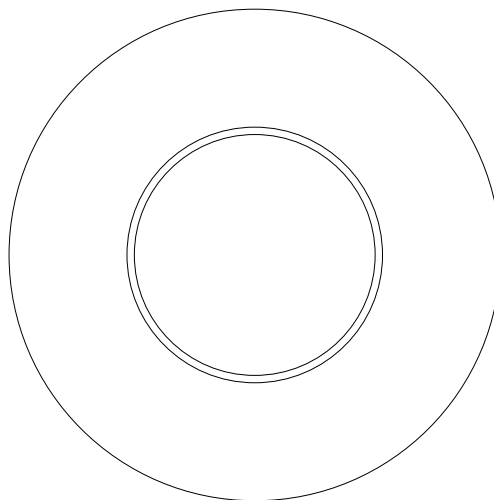
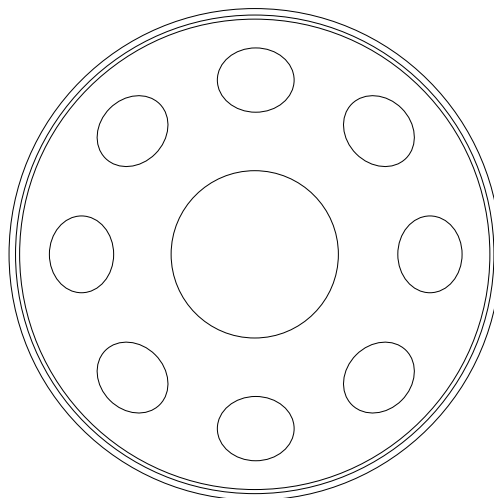
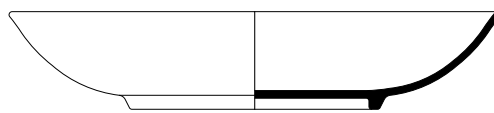

Fig. 1

References: Unpublished.

No. 41

Inv. No. MO1251 | Aron 374

*Exterior**Interior**Profile*

No. 41

Inv. No. MO1251 | Aron 374

Large porcelain bowl with a flat base on a ring foot, curved wall,
and straight rim; painted in black, green and red
China, 17th century

Dimensions: diam. 35.7 cm, h. 6.34 cm

Condition: Good; encrustations on the outer bottom.

Decorative Patterns

Exterior: Devoid of decoration.

Interior: Eight small circular medallions on the wall, one circular medallion on the bottom. Two continuous and parallel lines painted in red below the inner rim.

Content: Koranic verses and religious expressions in Arabic cursive (Figs. 1, 2).

Comment: This bowl is made of a porcelaneous stoneware commonly referred to as “Swatow” ware (from the port of Shantou, in northern Guangdong province), although the exact place of manufacture remains unknown. Like the previous example (no. 40), these bowls were produced for export, with the earliest examples dating from the late 16th century to the following century. These productions feature Arabic inscriptions—mainly concentrated on the inner surface—containing Koranic verses and fairly stereotyped religious formulas, distinguishing them from later productions by the absence of magic squares. Decorative motifs and inscriptions are generally painted in red, blue, black, and green.

References: Unpublished.



Fig. 1



Fig. 2

No. 42

Inv. No. MO1160 | Aron 273

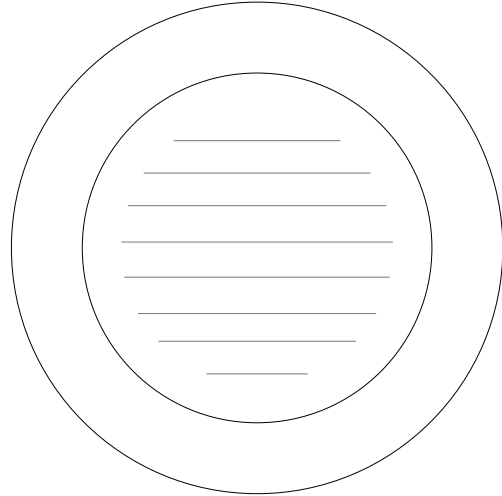
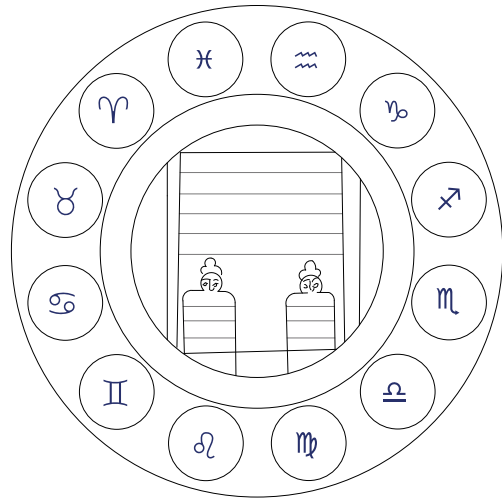
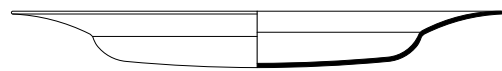
*Exterior**Interior**Profile*

No. 42

Inv. No. MO1160 | Aron 273

Plate with a slightly rounded base and horizontal rim;
blackish infill in the engravings
Iran, 19th century

Dimensions: diam. 17.43 cm, h. 2 cm, weight 217.4 g

Condition: Fair; infill largely lost.

Decorative Patterns

Exterior: Circular medallion.

Interior: Twelve circular medallions on the rim; a rectangular cartouche enclosed within a circle on the bottom.

Content: Numerical sequences, letters, and isolated words in Arabic cursive; a pair of human figures, each wearing a headdress with a trilobed profile (Fig. 1); depiction of the twelve zodiac constellations (Annex II).

Comment: The specimen is the first of five plates and features the absence of Arabic inscriptions, replaced by words, letters and numbers in Arabic. It is also distinguished by the presence of a pair of human figures, most likely male, which are frequently found both on magical plates and metal talismans (see also plates nos. 44 and 45). This type of iconography seems to be used to assure love. The zodiac signs are also attested on the inner wall of the rim of plate no. 46. In both cases, the constellations are enclosed within a circular frame.

References:

Unpublished.



Fig. 1

No. 43

Inv. No. MO1161 | Aron 252



Exterior

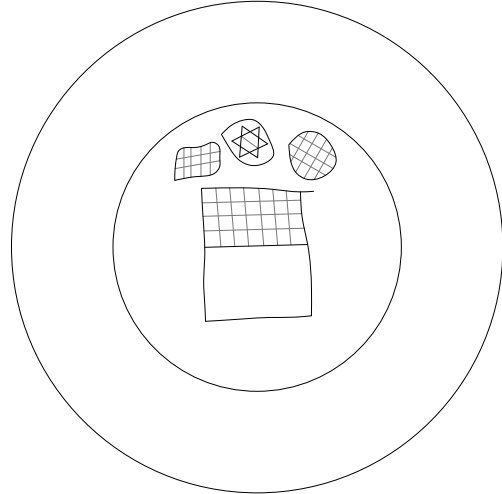

Interior

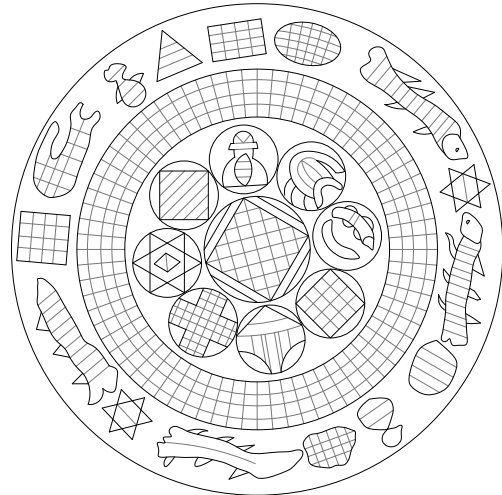

Profile



No. 43

Inv. No. MO1161 | Aron 252

Plate with a flat base and horizontal rim

Iran, 20th century

Dimensions: diam. 17.55 cm, h. 1.45 cm, weight 207.3 g*Condition:* Fair; traces of red and green color in some engravings.*Decorative Patterns**Exterior:* Three irregular circular medallions above a rectangular cartouche.*Interior:* Numerical grid on the wall and on the rim; eight circular medallions arranged around a central medallion on the bottom.*Content:* Six-pointed stars (Fig. 1), grids with numbers and non-Arabic magical characters; anthropomorphic and zoomorphic motifs, including human busts (Fig. 2), fishes, a scorpion and a serpent (Fig. 3).*Comment:* The specimen is the second of five plates and is the only one devoid of Arabic inscriptions. Its magical powers rely solely on Arabic numerals and characters from magical alphabets, enclosed within grids, geometric panels, and anthropomorphic and zoomorphic elements. No similar objects are known. However, it should be noted that the shape of the zoomorphic cartouches resembles that of some arm amulets.*References:* Unpublished.

Fig. 1



Fig. 2



Fig. 3

No. 44

Inv. No. MO1162 | Aron 274



Exterior

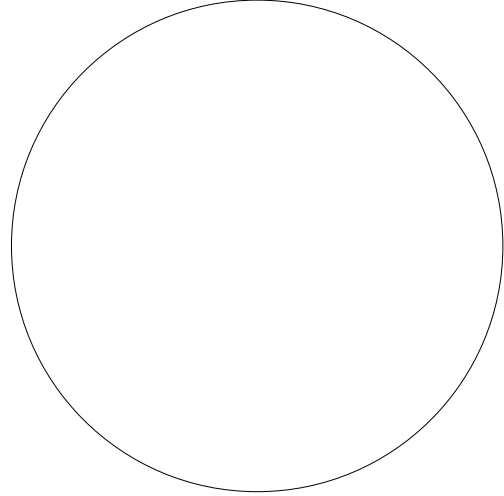

Interior

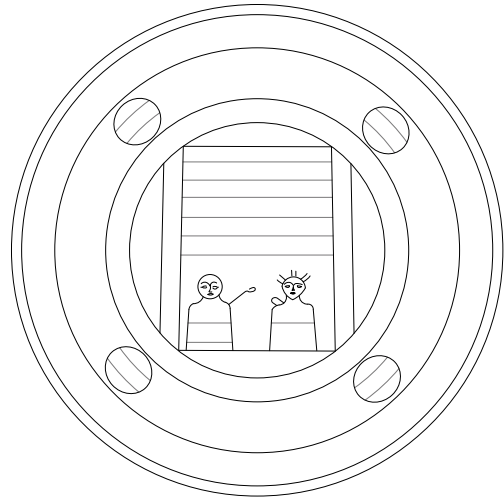

Profile



No. 44

Inv. No. MO1162 | Aron 274

**Plate with a flat base and horizontal rim;
blackish infill in engravings
Iran, 18th-19th century**

Dimensions: diam. 19.33 cm, h. 1.65 cm, weight 401.4 g

Condition: Good.

Decorative Patterns

Exterior: Devoid of decoration.

Interior: Concentric lines on the wall, interrupted by four equidistant circular medallions; rectangular cartouche on the bottom.

Content: Koranic verses, prayers and religious expressions in Arabic cursive; words, letters, and numbers in Arabic; magic symbols; owner's name in Arabic cursive (Fig. 1); anthropomorphic motifs composed of a pair of stylised human figures (Fig. 2), similar to those of plates nos. 42 and 45.



Fig. 1

Comment: Unlike plate no. 42, this specimen features, in addition to numerical sequences and isolated words and letters, many inscriptions in cursive Arabic. Two interesting aspects are the presence of the owner's name, engraved on the exterior below the rim, and the depiction of two human figures, rendered in a stylised manner, which occupy the lower part of the rectangular frame on the inner bottom. This iconography appears to be related to love (see plate no. 42).

References: Unpublished.



Fig. 2

No. 45

Inv. No. MO1163 | Aron 272

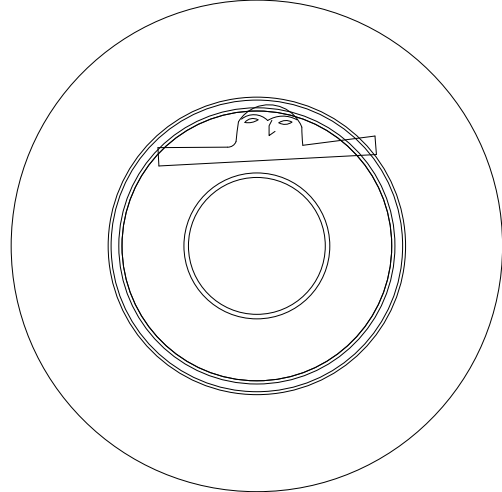
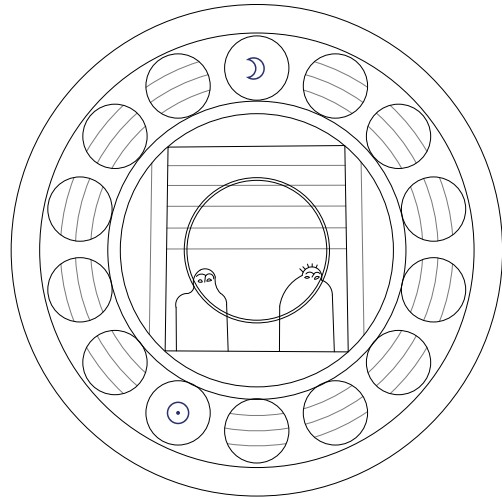
*Exterior**Interior**Profile*

No. 45

Inv. No. MO1163 | Aron 272

Plate with a slightly rounded base and short horizontal rim;
white/yellow infill in engravings
Iran, 17th-18th century

Dimensions: diam. 15.9 cm, h. 1.72 cm, weight 174.3 g

Condition: Fair. Many traces of oxidation.

Decorative Patterns

Exterior: Non-equidistant concentric circles.

Interior: Twelve circular medallions on the rim; large rectangular cartouche on the bottom.

Content: Religious prayers and expressions in Arabic cursive; words, letters, and numbers in Arabic; anthropomorphic motifs composed of the Sun, the Moon, the bust of a stylised male character (Fig. 1), and a pair of stylised human figures (Fig. 2).

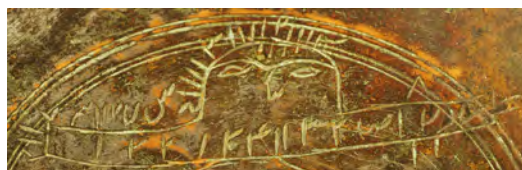

Fig. 1

Comment: The twelve circular medallions on the rim evoke the 12 zodiac constellations (see no. 46). For the depiction of the pair of human figures and their likely meaning, see plates nos. 42 and 44. A hook used for suspension has been added to the outer wall of the rim.

References: Unpublished.



Fig. 2

No. 46

Inv. No. MO1164 | Aron 167



Exterior

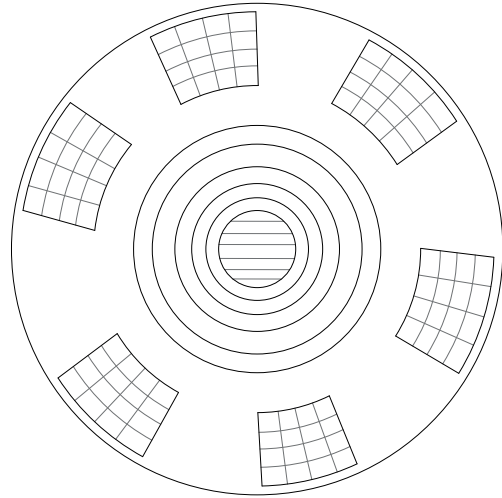

Interior

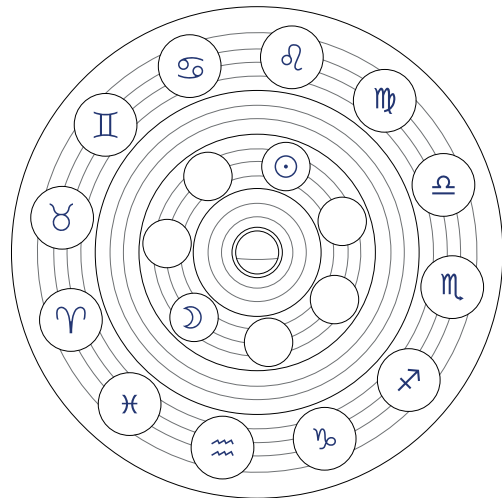

Profile

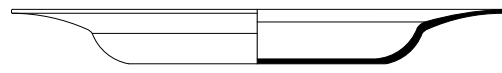

No. 46

Inv. No. MO1164 | Aron 167

Plate with a flat base and wide horizontal rim;
blackish infill in the engravings
Iran, 16th-17th century

Dimensions: diam. 20.32 cm, h. 2.25 cm, weight 511 g

Condition: Fair; infill moderately to heavily worn; some areas of illegible writing. Sporadic oxidations on the outer wall.

Decorative Patterns

Exterior: Six magic squares on the rim and concentric lines enclosed within a circular medallion on the bottom.

Interior: Concentric lines on the rim, the wall, and the bottom. Those on the wall and the bottom are interrupted by twelve and seven circular medallions, respectively. A circular medallion stands out at the center of the bottom.

Content: Koranic verses and religious expressions in Arabic cursive; sequences of Arabic letters and numbers; six alphabetic 4×4 magic squares—five of which are constructed using five of the 99 “Beautiful Names” of God, and one with the magic word *budūh* (Figs. 1, 2); anthropomorphic and zoomorphic motifs, including the Sun and the Moon, as well as the 12 zodiac signs arranged in a clockwise direction (Annex II).

Comment: In terms of shape and weight, the plate compares to specimens nos. 43 and 44, from which it differs in the quality of the engravings and the presence of the 12 zodiac constellations, the depiction of the Sun and the Moon, and the six magic squares. In all cases, the words of the magic squares are readable along the horizontal and vertical lines; the two diagonals contain the repetition of the same letter. All the inscriptions and the alphabetical and numerical sequences on the interior are arranged on concentric lines, executed in engraving. The number 4 is transcribed in the Persian manner.

References: Unpublished.



Fig. 1



Fig. 2



Catalogue – Part Two

MICHELE BERNARDINI



Introduction

The second part of this catalogue, comprising 61 bowls (nos. 47-108), shows the substantial difference between two types of bowls that are both present in the collection: the magical-therapeutic ones and those used for ritual divination. The former are smaller in size, characterised by essential ornamentation and often by a limited use of written texts. The latter are more complex in form, distinguished by a central umbo rising from the centre of the surface, they all feature a curved wall and are entirely covered with written texts over the entire surface. Both types of objects were made over a very long period of time (13th–21st century) and often performed similar functions: in the earliest examples, their use was primarily connected with the treatment of illnesses and discomforts, whereas in more recent ones, other features were added: they were used as gifts, particularly for those making pilgrimages to Mecca or to the holy sites of Shi‘ism. Their use was also of a devotional nature: the bowl could serve the function of a portable “metal book”. Many of the characteristics of older bowls can be found in newer bowls, such as astrological references or even some talismanic formulas. For example, the frequent presence of the zodiac or references to the planets in the earlier bowls reflects a role linked to divinatory practice and astrology. In the more recent examples, however, this symbology becomes increasingly stereotypical and conventional and is in fact a kind of fossilised reference to more ancient and complex practices. The pervasive use of prayers and especially Koranic verses or entire Surahs in the more recent examples is indicative of the spread of new practices, especially from the 15th century onwards. It should be noted that from the 15th century onwards, bowls begin to incorporate formulas and references to the Shi‘ite world, indicating quite conspicuously the success of bowls in that sphere, coinciding with the rise of Shi‘i movements and their doctrine. But the religious formulas of the bowls that spread initially in Iran are later found in many examples throughout Muslim Asia.

The first section of the catalogue is made up of a series of bowls produced in Iran or Mesopotamia from the second half of the 15th to the 16th century (nos. 47–67). In the earliest examples (nos. 47–51) a repertoire of very particular prayers, such as the *du‘ā’ al-Idrīsiyya*, or Idrīs prayer, and often the use of zodiacal signs indicate, on the one hand, the detachment from previous models and, on the other, the introduction of new traditions. These bowls date

from the second half of the 16th century, as evidenced by one example dated 875/1470–71, clearly of Iranian origin, probably made in Yazd or Kāshān, one of the main centres for the production of this type of object. This is the case with the first appearance of the *Chahārdah ma‘šūm*, i.e. the Shi‘i family consisting of Muḥammad, Fāṭima and the 12 imams, each mentioned with a relative epithet (no. 51; Fig. 1).



Fig. 1. Inscription with the the *Chahārdah ma‘šūm* and the Zodiac, no. 51

The repertoire of prayers was consolidated during the Safavid period (nos. 52–67) with the introduction of new formulas and the definitive placement in pre-established positions of some invocations and prayers that mark the beginning and end of the integral reading of the bowl. While almost all of them have the *Chahārdah ma‘šūm* (“The Fourteen Infallibles”), almost always placed beneath the rim, they are also characterised by the prominent position of the Throne Verse (the *Āyat al-Kursī*, Kor. 2:255) generally on the surface of the rim and an invocation, the *Nādi ‘Aliyyan* (“Call upon ‘Alī”) in the part surrounding the umbo of the bowl.

The Throne Verse holds particular importance in magical practices, while *Nādi ‘Aliyyan* constitutes a declaration of adherence to the Shi‘ite faith. This is the case of some bowls produced in Fārs, often signed and dated, such as no. 64 made in 1051/1641–42 by Taqī Šīrāzī, which is characterised by a smaller shape and the use of a turquoise stone set on the upper part of the umbo (Fig. 2).

An important example belonging to this group is signed by Ḥusayn Kāshānī (no. 55, Fig. 3), an artist known for many other examples preserved at the Hermitage in St. Petersburg, at the National Museum of Scotland in Edinburgh and at the Museo delle Civiltà in Rome.

A very particular group of bowls of Syrian or Mesopotamian production (nos. 69–70, 77–78, 83), show a completely different repertoire, excluding almost all Shi‘i references and introducing a series of invocations around the umbo that always include epithets referring to God. These epithets are not part of the conventional use of the *Asmā’ al-ḥusnā* (“The Beautiful Names [of God]”), which are also frequently used in many bowls. This type of bowl was



Fig. 2. The Nādi ‘Aliyyan around the umbo, no. 63



Fig. 3. The signature of Ḥusayn Kāshānī, no. 55

defined by the double invocation that generally introduces a series of four cartouches containing epigraphs arranged around the umbo: *yā Kāfī*, *yā Shāfī* (O Clear! O Sufficient!). First identified in a pioneering study by Canaan (1936), this designation applies to objects from the Syro-Palestinian area (Fig. 4).

Two bowls (nos. 78 and 102) with the names of angels (Jibrā’īl; Mikā’īl; Azrā’īl; Isrāfīl and Dardanīl) reveal the existence of a widespread group that was very common in the Sunni context of the Near East (e.g. no. 78, Fig. 5).

The bowl no. 102 is also characterised by a small plate fixed to the upper end of the umbo that was used to fix keys, following a typology known as *chihil kilīd* “forty keys”, often studied by anthropologists who note that its magical practice continues to the present day.

One of the most widespread practices in the Iranian-Indian area is to insert the entire 36th Surah of the Koran (the Surah *Yā Sīn*) into the bowls. This Surah is dedicated to two letters of the Arabic alphabet, the esoteric meaning of which is known “only to God”. It is also known as the “Heart of the Koran” and is often used in funeral ceremonies and other rituals, including magical ones. It is often reproduced in full, sometimes in complex inscriptions that take up the entire surface of the bowls and form grids and textual “vortexes” (see nos. 79–86; Fig. 6).



Fig. 4. Inscription with the invocation *yā Kāfī*, *yā Shāfī*



Fig. 5. *The Names of the Angels*, no. 78

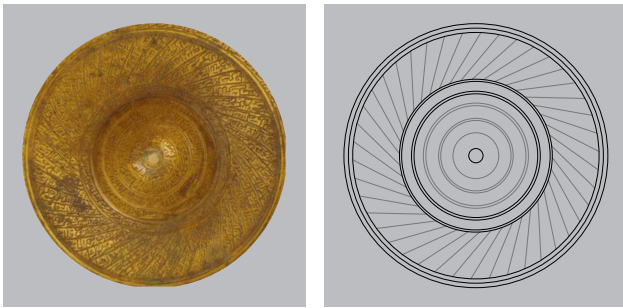

Fig. 6. Example of “vortex” writing, no. 82

A conspicuous group of bowls from Anatolia (nos. 90–100) is distinguished by a different body shape. Equipped with a flat base and rim, these bowls feature a truncated cone-shaped umbo and an epigraphic apparatus limited to a few essential Koranic references—particularly the *Āyat al-kursī*—accompanied by numerous magical inscriptions. These writings are primarily monograms, often containing the names of Allāh and ‘Alī. These specimens date from the 18th to the 19th century.

Other Anatolian bowls characterise the variety of the Ottoman production. For example, there is a bowl dated 1161/1748 that bears the name of the owner ‘Atiya Khātūn (no. 87), produced in Anatolia with the typical stylistic features of the period.

Fig. 7. *The Āyat al-kursī and below the monogram ‘Alī*, no. 96





Fig. 8. The interior of the bowl no. 87

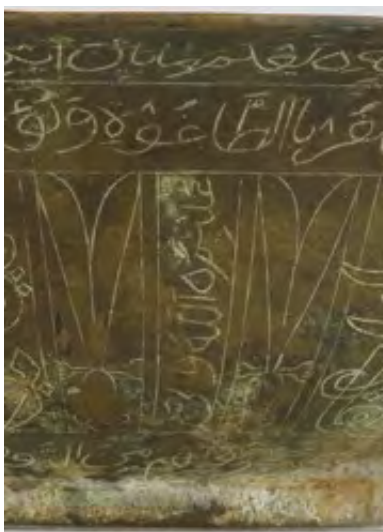
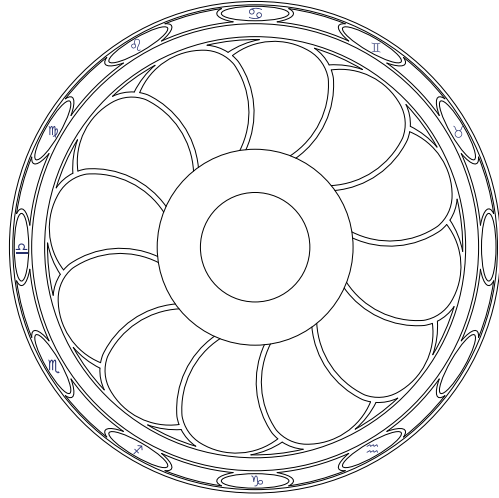
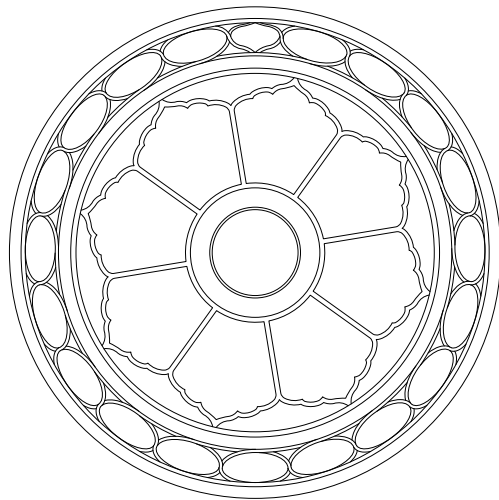
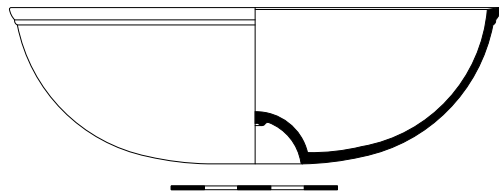

*Fig. 9. The swords of Dhū'l-faqār,
no. 75*

Three bowls from the Indian world are worth mentioning, characterised by their elongated sides and the nature of their texts and illustrations (nos. 74–76). They date from the 18th, although their production continued into the 20th century. While reproducing the textual repertoire of the bowls produced in Iran, these bowls introduce depictions of the so-called swords of *Dhū'l-faqār* together with an invocation dedicated to 'Alī. Bearing distinctive magical texts, they form a category of their own (Fig. 9).

No. 47

Inv. No. MO1235 | Aron 267

*Exterior**Interior**Profile*

No. 47

Inv. No. MO1235 | Aron 267

Bowl with curved wall and hemispherical umbo,
flat base, slightly everted edge and flat rim
Iran, 15th-16th century

Dimensions: diam. 14.83 cm, h. 4.7 cm, weight 320.2 g

Condition: Fair; significant loss of inscriptions on the interior.

Content: A divinatory-ritual bowl with a rich repertoire of Koranic inscriptions, prayers and zodiacal signs, alternating with additional prayers and invocations.

Exterior: An upper band with circular medallions containing the signs of the zodiac (Figs. 1-3) alternated with square cartouches bearing Koranic verses. Below, overlapping cartouches contain the *Asmā' al-husnā* ("The Beautiful Names [of God]"). The band is surmounted by a continuous inscription with Koranic verses.

Interior: In the upper band, 20 side-by-side cartouches containing the *du'ā' al-Idrīsiyya* are arranged beneath the rim; below, eight niche-shaped cartouches with a polylobed upper end, containing the continuation of the *du'ā' al-Idrīsiyya*, are surmounted by a continuous epigraphic band encircling the entire bowl. The umbo, which is very worn, bears no trace of the original inscription.

Comment: Due to its inscriptions and decorative style, this bowl appears to be one of the earlier Persian "Shi'i" specimens within a large family. Its epigraphic apparatus, which covers the entire surface, is limited to various prayers and a few conventional Koranic references.

References: Bernardini in press.



Fig. 1



Fig. 2



Fig. 3

No. 48

Inv. No. MO1229 | Aron 101



Exterior

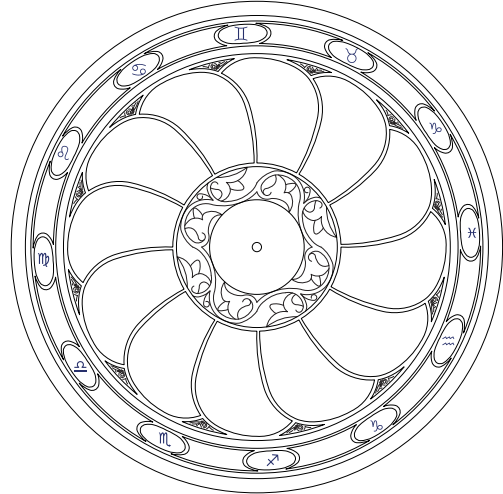

Interior

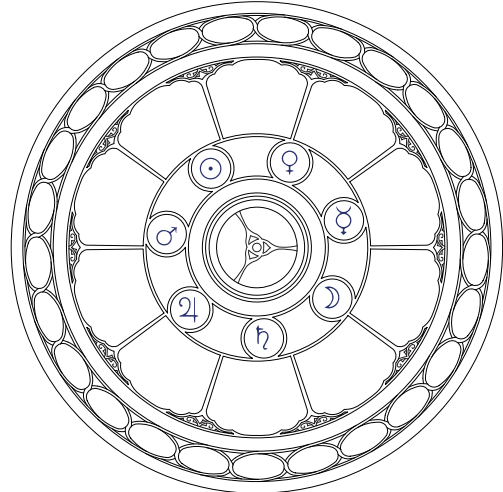

Profile

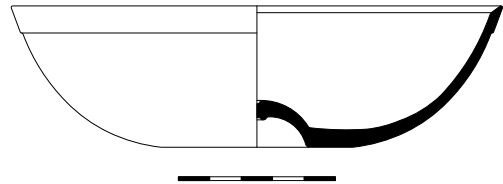

No. 48

Inv. No. MO1229 | Aron 101

Bowl with curved wall and hemispherical umbo,
flat base, and flat rim
Iran, 15th century

Dimensions: diam. 15.65 cm, h 4.5 cm, weight 313.5 g

Condition: Good; a welding on the wall.

Content: A divinatory-ritual bowl with Koranic inscriptions, prayers and Shi'ī invocations.

Exterior: Beneath the rim is a band containing the 12 signs of the zodiac in roundels (Figs. 1–3), alternating with cartouches containing Koranic verses and the *Asmā' al-ḥusnā* (“The Beautiful Names [of God]”). At the centre of the wall is a second continuous inscription with the *Asmā' al-ḥusnā*. In the lower part, 12 oval cartouches, arranged as overlapping niches, contain the prayer to Adam and Eve (*khuṭba Ādam wa Huwwā*). The umbo is surrounded by a palmette scroll.

Interior: The rim bears the *Āyat al-kursī* (the Throne Verse, Kor. 2:255), beneath which are 25 circles containing the *Du'ā' Idrisīyya* (Prayer of Idris). Below this is an inscription continuing the prayer. In the lower part, 12 polylobed niches contain the conclusion of the *Du'ā' Idrisīyya* and the *Jawshan al-Kabīr* (The Greater Armour). Around the umbo, a band with the six planets in roundels alternates with an inscription continuing the *Jawshan al-kabīr*. The umbo itself is encircled by a continuous inscription with the *Jawshan al-kabīr*, ending in the tripartite umbo.

Comment: This bowl is similar to no. 47, and may be one of the earliest known examples of its type.

References:

Bernardini in press.



Fig. 1



Fig. 2



Fig. 3

No. 49

Inv. No. MO1222 | Aron 280



Exterior

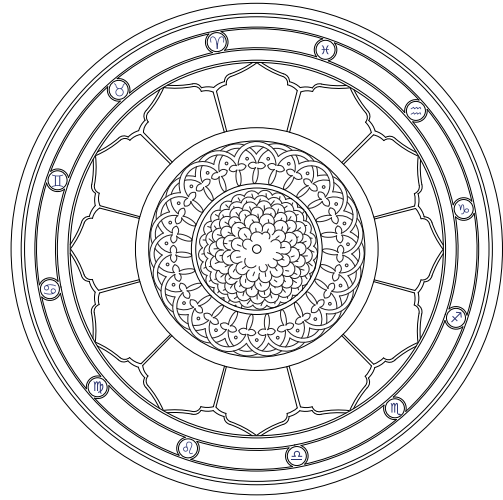

Interior

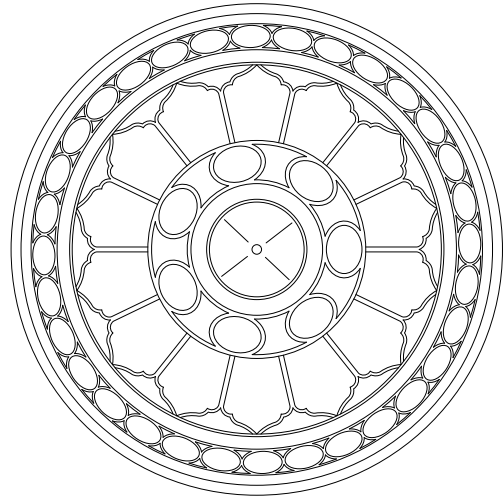

Profile

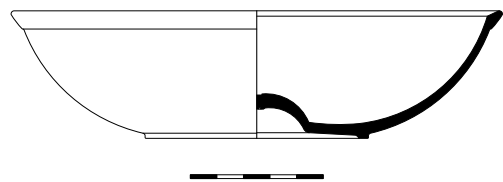

No. 49

Inv. No. MO1222 | Aron 280

Bowl with curved wall, hemispherical umbo,
ring-shaped base, protruding and flat rim
Iran or Mesopotamia, 16th century

Dimensions: diam. 18.5 cm, h 4.8 cm, weight 481.4 g

Condition: Fair; a break at the rim and various signs of use.

Content: A divinatory-ritual bowl with Koranic inscriptions, prayers and Shi'i invocations.

Exterior: The outer part of the rim is decorated with an interlace of silver incrustations (the same technique issued in other parts of the bowl). At the bottom is an inscription with the *Chahārdah ma'šūm* ("The Fourteen Infallibles"; Fig. 1), above which is a band with alternating signs of the zodiac in roundels (Fig. 2) and cartouches with the prayer of Adam and Eve (*khuṭba Ādam wa Huwwā*). In a central band of the wall appears the invocation *Nādi 'Aliyyan* ("Call upon 'Alī"), beneath which are 12 cusped niches containing an illegible inscription, alternating with 12 inverted triangles bearing the *Asmā' al-ḥusnā* ("The Beautiful Names [of God]").



Fig. 1

Interior: An illegible inscription appears on the surface of the rim. Below the rim is the *Āyat al-kursī* (the Throne Verse, Kor. 2:255) in a continuous inscription. Beneath this, 32 side-by-side roundels containing the *Du'ā' al-Idrīsīyya* (Prayer of Idris), above a continuous inscription with Koranic verses. In the lower part of the umbo, 14 cusped cartouches contain the continuation of the *Du'ā' al-Idrīsīyya*. The umbo is further decorated with four illegible cartouches. Around the umbo are the six planets depicted in roundels.

Comment: The bowl is a late variant of the type already described in no. 47. In terms of its textual content, it can be traced back to Safavid period bowls, even though it reproduces a definitely earlier model, featuring the use of incrustation, a technique rare in the bowls after the 15th century (see no. 53).

References: Bernardini in press.



Fig. 2

No. 50

Inv. No. MO1201 | Aron 241



Exterior

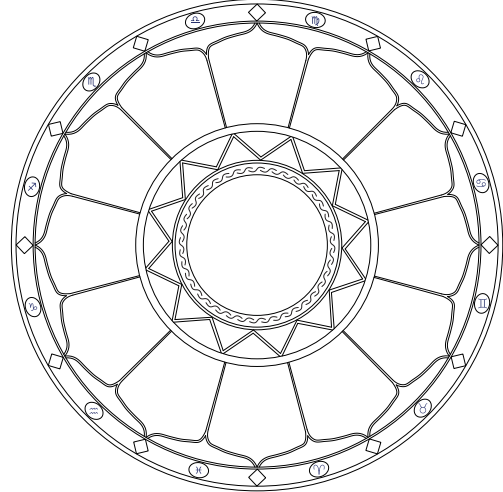

Interior

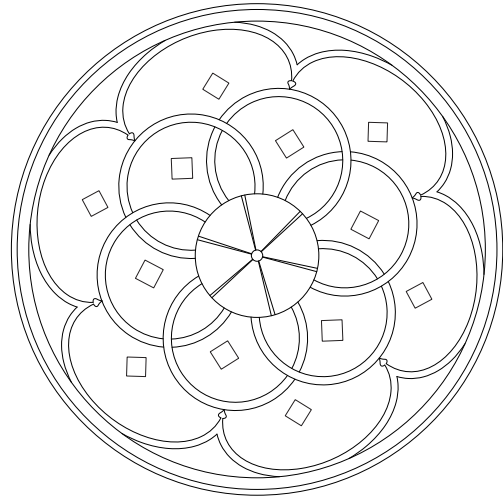

Profile

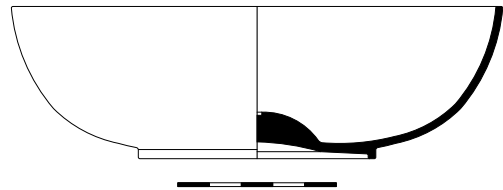

No. 50

Inv. No. MO1201 | Aron 241

Bowl with curved wall and hemispherical umbo,
ring-shaped base, straight and flat rim
Iran, 16th century

Dimensions: diam. 15.5 cm, h 4.91 cm, weight 373.6 g

Condition: Good; on the inside, the umbo has been filled with clay.

Content: A divinatory-ritual bowl.

Exterior: Below the rim, 24 cartouches containing the 12 signs of the zodiac within circular elements alternating with various Koranic verses. Between the cartouches are square Kufic inscriptions that include the monogram Allāh (Fig. 1). The inscriptions continue on the wall with pointed arch motifs entirely filled with inscriptions bearing the *du‘ā’ al-Idrīsīyya*, or Idrīs prayer. At the base is a motif of 24 triangular cartouches containing invocations of forgiveness. The interior of the umbo was filled with cement.

Interior: Below the rim appears an inscription with the *Chahārdah ma‘šūm* (“The Fourteen Infallibles”), and the *Nādi ‘Aliyyan* (“Call upon ‘Alī”). The entire interior wall bears a decoration of 26 overlapping “petal” cartouches (Fig. 2) derived from the interlacing of a circular ribbon motif. Also on the inside, monograms of Allāh in square script appear in the centre of the overlapping petal design. The worn umbo is divided into six triangular segments entirely filled with text.

Comment: This bowl is characterised by a particularly minute cursive script that pervades the entire surface of the object. The bowl is a variant of the type already described in no. 47. On the basis of its inscriptions, it can be traced back to the Safavid period bowls.

References: Bernardini in press.



Fig. 1

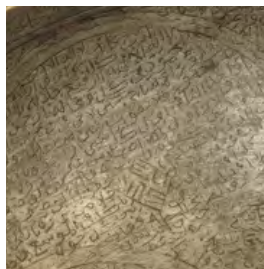

Fig. 2

No. 51

Inv. No. MO1242 | Aron 243



Exterior

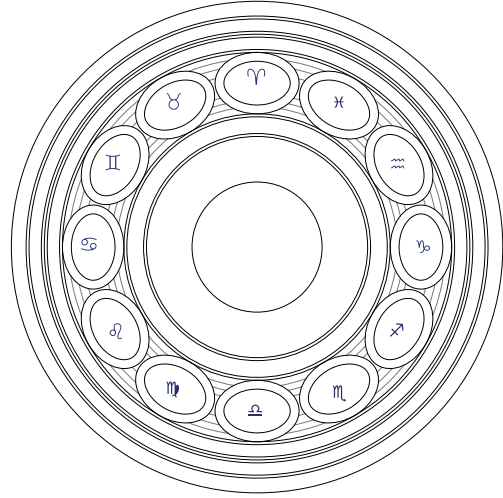

Interior

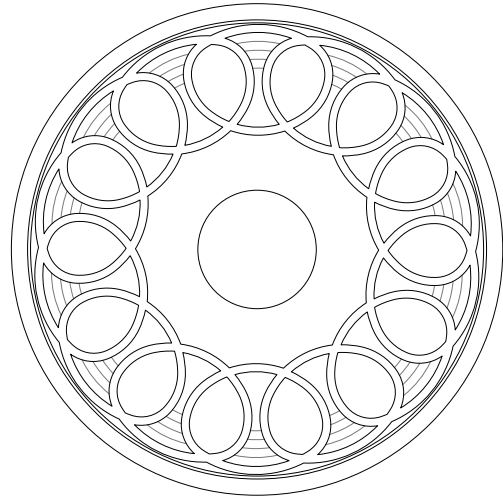

Profile

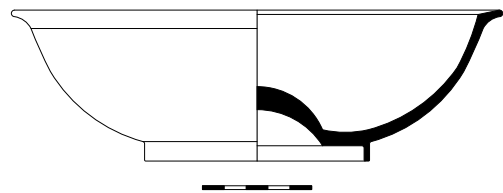

No. 51

Inv. No. MO1242 | Aron 243

Bowl with curved wall and hemispherical umbo,
ring-shaped base, straight and everted horizontal rim
Iran, 875/1470-71

Dimensions: diam. 22.5 cm, h. 6.91 cm, weight 795 g

Condition: Poor; the interior is completely obliterated due to use.

Content: A divinatory-ritual bowl with a rich repertoire of Koranic and Shi'i inscriptions.

Exterior: On the outer surface of the rim, and just below it, are two magical alphanumeric inscriptions. Below the rim, into a continuous profiled inscription is the *Chahārdah ma'sūm* ("The Fourteen Infallibles"). The wall is decorated with 12 roundels with the Zodiacal signs (Fig. 1). Magical alphanumeric inscriptions on four lines are arranged in the interstitial spaces. A continuous Koranic inscription is arranged around the base.



Fig. 1

Interior: On the wall is a continuous inscription with the *Āyat al-kursī* (the Throne Verse, Kor. 2:255-257) and other Koranic Surahs. At the end of the inscription is engraved the date 875/1470-71 (Fig. 2). Due to wear, the interior of the bowl is illegible; nevertheless, it preserves a decorative grid formed by a continuous ribbon forming 14 almond-shaped patterns.

Comment: This elegant specimen, although damaged on the inside, is part of a group of bowls made in Iran between the 15th and 16th centuries. These bowls share common characteristics, starting with the emphasis on the text of the *Chahārdah ma'sūm*. Stylistically, they reflect metalworks of the period (see no. 52).

References: Bernardini in press.



Fig. 2

No. 52

Inv. No. MO1249 | Aron 293



Exterior

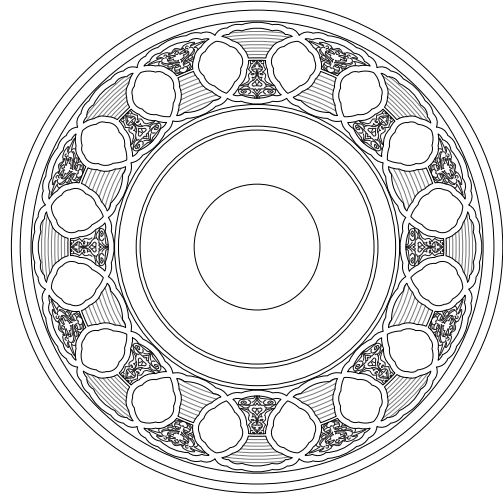

Interior

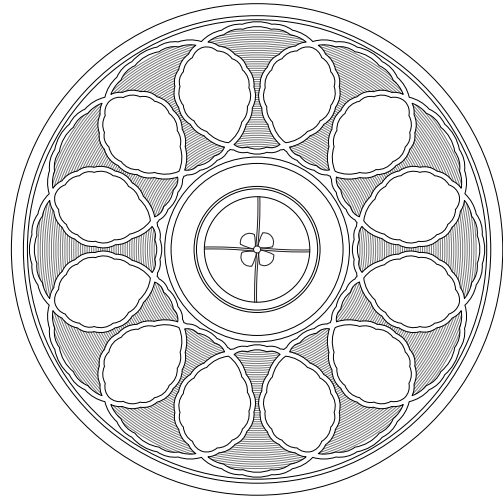

Profile

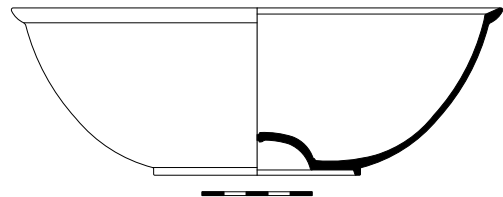

No. 52

Inv. No. MO1249 | Aron 293

Bowl with curved wall and hemispherical umbo with grooves,
ring-shaped base, horizontally everted rim
Iran, 991/1583-84

Dimensions: diam. 22.5 cm, h. 6.91 cm, weight 795 g

Condition: Poor; the interior is partially obliterated from use.

Content: A divinatory-ritual bowl with a rich repertoire of Koranic and Shi'i inscriptions.

Exterior: On the exterior surface of the rim and immediately below are two magical alphanumeric inscriptions. Beneath the rim, into a continuous profiled inscription is the *Chahārdah ma'şūm* ("The Fourteen Infallibles"). The surface of the outer wall is decorated with a grid formed by a continuous ribbon creating 16 almond-shaped patterns, which contains Koranic verses, magical numerical texts, and vegetal decoration (Fig. 1). In a cartouche there is the date 991 (1583-84; Fig. 2). A continuous Koranic inscription is arranged around the base.



Fig. 1

Interior: On the wall is a continuous Koranic inscription. Due to wear, the interior is illegible; nevertheless, it preserves a decorative grid formed by a continuous ribbon creating 12 almond-shaped patterns.

Comment: This specimen, damaged on the inside, is part of a group of bowls made in Iran between the 15th and 16th centuries. These bowls share common characteristics, starting with the emphasis on the text of the *Chahārdah ma'şūm*. Stylistically, they reflect metal objects of the period (see no. 51).

References: Bernardini in press.

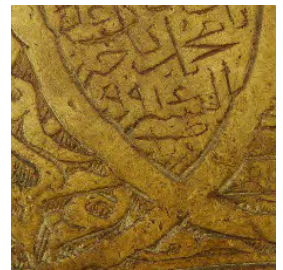

Fig. 2

No. 53

Inv. No. MO1203 | Aron 109



Exterior

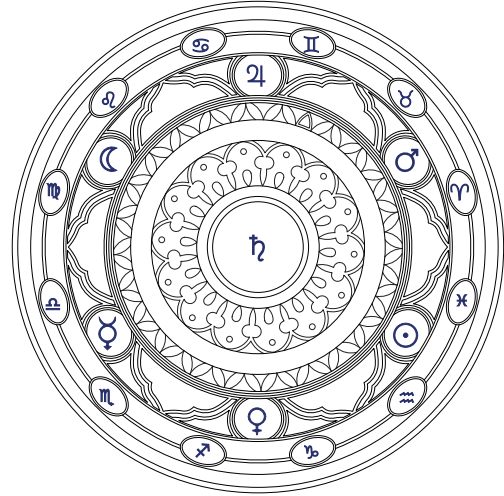

Interior

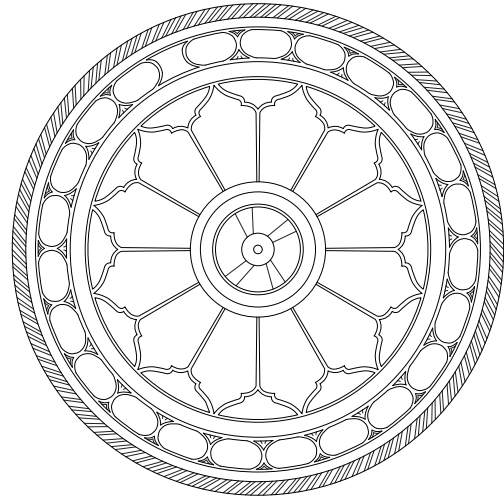

Profile

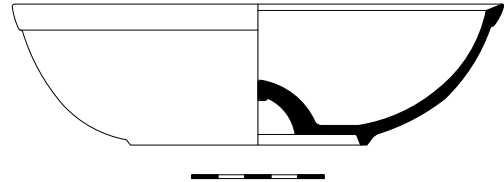

No. 53

Inv. No. MO1203 | Aron 109

Bowl with ring base, hemispherical umbo,
curved wall, slightly everted rim
Iran, 16th century

Dimensions: diam. 18.55 cm, h 5.32 cm, weight 587 g

Condition: Good; a few traces of restorations.

Content: A divinatory-ritual bowl with a rich repertoire of Koranic inscriptions, Shi'i invocations, and priers.

Exterior: At the bottom is a silver-inlaid inscription (Fig. 1) with the *Chahārdah ma'sūm* ("The Fourteen Infallibles"). Above it runs a band with alternating signs of the zodiac in roundels and cartouches—some of them bearing captions—together with the *Nādi 'Aliyyan* ("Call upon 'Alī"). Below are six roundels with the planets Jupiter, Mars (Fig. 2), Venus, Mercury, the Sun, and the Moon, alternating with six mountains-shaped motifs. In the interstitial spaces appear the names of 'Alī, Muḥammad, Allāh and Fāṭima. Two vegetal friezes surround the base of the umbo, which contains the image of Saturn (Fig. 3).

Interior: Below the rim runs a continuous inscription with the *Āyat al-kursī* (the Throne Verse, Kor. 2:255). Beneath it are 23 side-by-side roundels containing the *Du'ā' al-Idrīsīyya* (Prayer of Idrīs), surmounted by a continuous Koranic inscription. In the lower part of the umbo, 12 polylobed cartouches contain the continuation of the *Du'ā' al-Idrīsīyya*. Around the umbo is another continuous Koranic inscription. The umbo surface is decorated with four vertical cartouches with a Koranic verse.

Comment: The bowl is a late variant of the type already described in no. 47. For the texts it contains, it can be traced back to the Safavid period, although it reproduces a markedly earlier model, distinguished by the use of incrustation, a feature that became rare in such bowls after the 15th century.

References: Bernardini in press.



Fig. 1

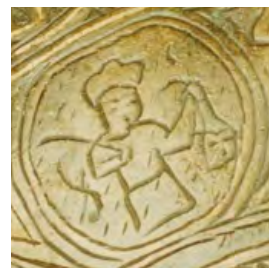

Fig. 2



Fig. 3

No. 54

Inv. No. MO1206 | Aron 253



Exterior

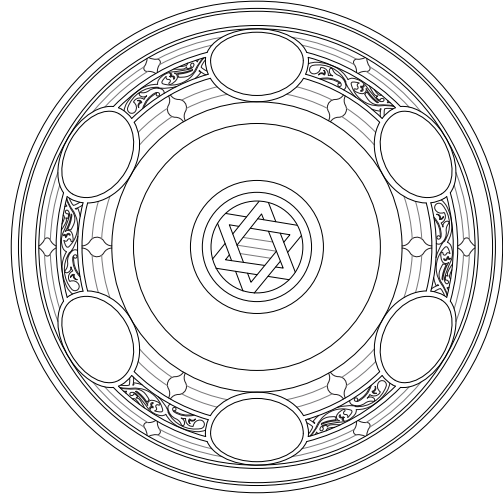

Interior

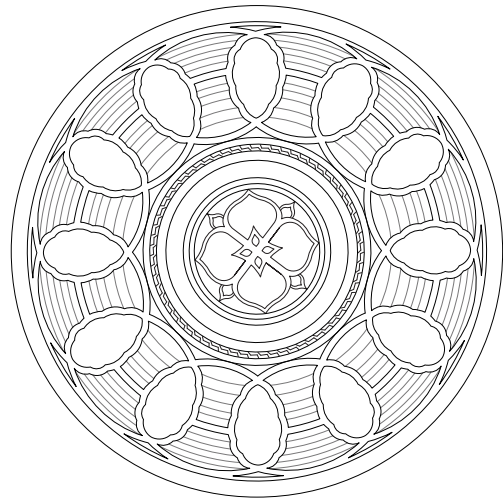

Profile

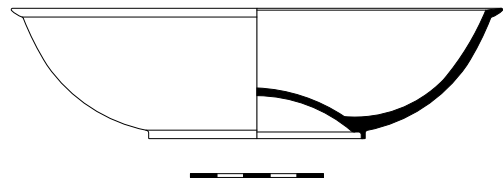

No. 54

Inv. No. MO1206 | Aron 253

Bowl with ring base, hemispherical umbo,
curved wall, everted rim
Iran, mid-16th century

Dimensions: diam. 18.48 cm, h. 4.9 cm, weight 299.8 g

Condition: Good.

Content: A divinatory-ritual bowl with a rich repertoire of Koranic inscriptions, and Shi'i invocations.

Exterior: On the outer surface of the rim is a continuous inscription with the *Āyat al-kursī* (the Throne Verse, Kor: 2:255). Below the rim is an inscription on a dashed background with the *Chahārdah ma'ṣūm* ("The Fourteen Infallibles"; Fig. 1). Below is a frieze consisting of six medallions linked together by a horizontal vegetal frieze. The text in the medallions contains Koranic verses. Magical alphanumeric inscriptions appear in the interstitial spaces. On the base of the umbo appears a seal of Solomon with a numerical inscription on three lines.



Fig. 1

Interior: On the inner surface, within 12 almond-shaped cartouches created by the interlacing of a continuous ribbon, is a Koranic inscription (Fig. 2). In the interstitial spaces formed by the interlacing of 12 overlapping circles, alpha-numerical inscriptions arranged in parallel lines are preserved. The umbo is decorated with a vegetal motif.



Fig. 2

Comment: This bowl belongs to a family of objects produced in central Iran around the mid-16th century.

References: Bernardini in press.

No. 55

Inv. No. MO1205 | Aron 330

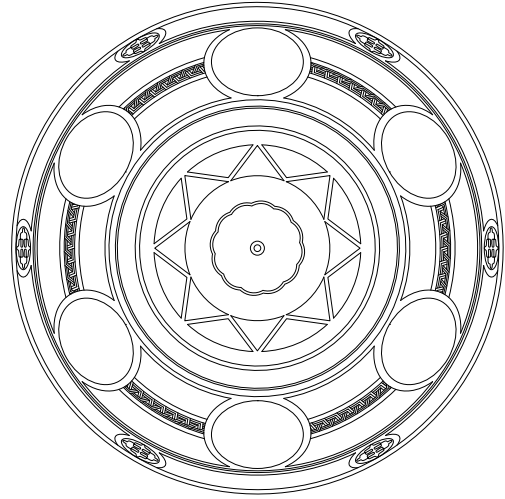
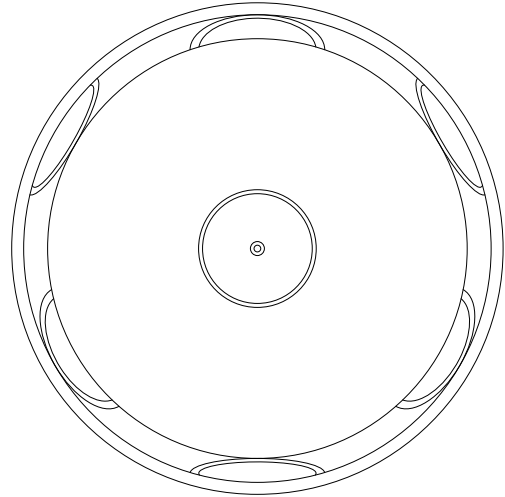
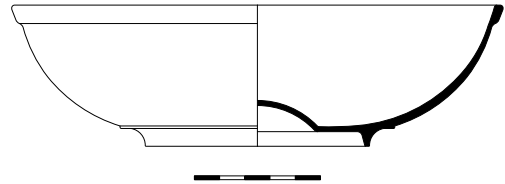
*Exterior**Interior**Profile*

No. 55

Inv. No. MO1205 | Aron 330

Bowl with ring base, hemispherical umbo,
curved wall, bulging rim
Iran, Kāshān, mid-16th century

Dimensions: diam. 19.5 cm, h 5.6 cm, weight 428 g

Condition: Bad; many parts completely obliterated, especially on the interior.

Content: A divinatory-ritual bowl with a rich repertoire of Koranic inscriptions and Shi'i invocations.

Exterior: Below the rim is an inscription with the *Chahārdah ma'sūm* ("The Fourteen Infallibles"; Fig. 1). The inscription, on a background filled with black bitumen, is broken up by circular roundels with a lily-tipped cross inside. Below is a frieze consisting of six medallions linked together by a horizontal geometric frieze. The text in the medallions is illegible. On the base around the umbo, 16 triangular cartouches are arranged inverted to each other with invocations for the owner. On the outer surface of the umbo appears the signature of the craftsman in a polylobed roundel "*'amal Ḥusayn Kāshānī*" (the work of Ḥusayn Kāshānī, Fig. 2).



Fig. 1

Interior: Illegible, with only a faint glimpse of what remains of a geometric pattern.

Comment: The presence of the craftsman's signature allows the specimen to be traced back to a known type found at the Hermitage in St. Petersburg (inv. IR-2191, dated 959/1552; and IR-2192 undated), at the National Museum of Scotland in Edinburgh (inv. 1886-393), and at the Museo delle Civiltà in Rome (inv. 21151).



Fig. 2

References: Bernardini in press.

No. 56

Inv. No. MO1246 | Aron 208



Exterior

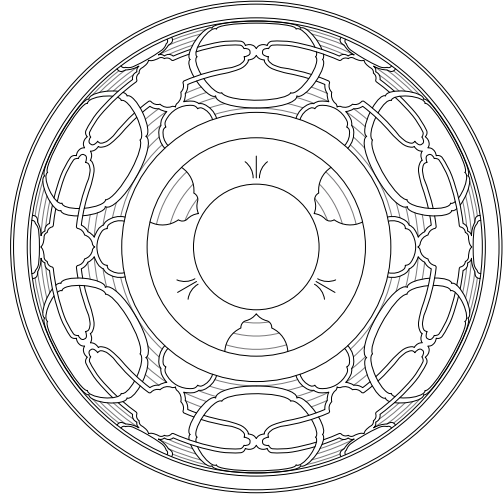

Interior

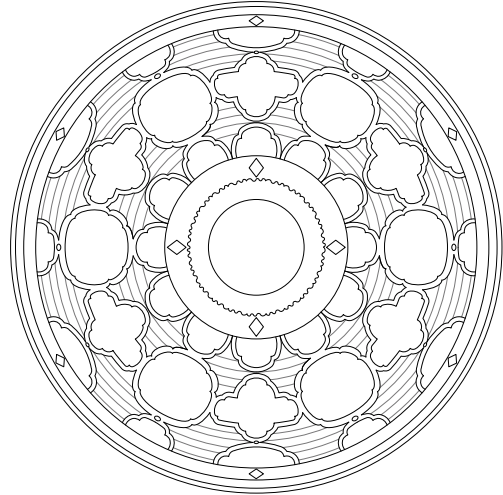

Profile

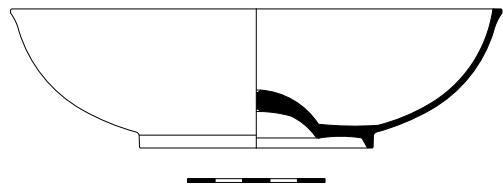

No. 56

Inv. No. MO1246 | Aron 208

Bowl with ring-shaped base, hemispherical umbo, curved wall, straight edge, flat rim
Anatolia, Mesopotamia, 16-17th century

Dimensions: diam. 17.92, h. 5.07 cm, weight 319 g

Condition: Fair; large loss of inscriptions due to use.

Content: A divinatory-ritual bowl with a rich repertoire of Koranic inscriptions and Shi'i invocations.

Exterior: An upper band with a continuous inscription with the *Chahārdah ma'šūm* ("The Fourteen Infallibles"). The wall is decorated with circular cartouches intersected by *tabulae ansatae* motifs (Fig. 1). The cartouches contain Koranic inscriptions within the circular sections, while the remaining areas are decorated with vegetal motifs. All interstitial spaces are filled with magical numerical inscriptions on horizontal lines. Three triangular mountain-shaped motifs (Fig. 2) with numerical inscriptions are arranged in parallel lines on the surface of the base.

Interior: On the upper wall, a continuous inscription with the *Āyat al-kursī* (the Throne Verse, Kor: 2:255) is segmented by rhombus-shaped divisions. In the centre of the wall, a design alternates circular cartouches and four-lobed medallions containing Koranic verses and vegetal motifs. The interstitial spaces are entirely filled with numerical inscriptions arranged in parallel lines. Around the umbo runs a Koranic inscription interspersed with rhombuses motifs. The umbo is covered with a vegetal design (Fig. 3).

Comment: This bowl is part of a group of homogeneous objects with similar shape, weight and decorative types. The main characteristic is the use of alternating numerical magic inscriptions and designs in the form of *tabula ansata* with circular or polylobate cartouches (see nos. 57–60).

References: Unpublished.



Fig. 1



Fig. 2

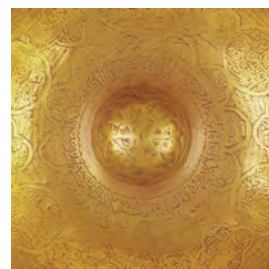

Fig. 3

No. 57

Inv. No. MO1232 | Aron 262



Exterior

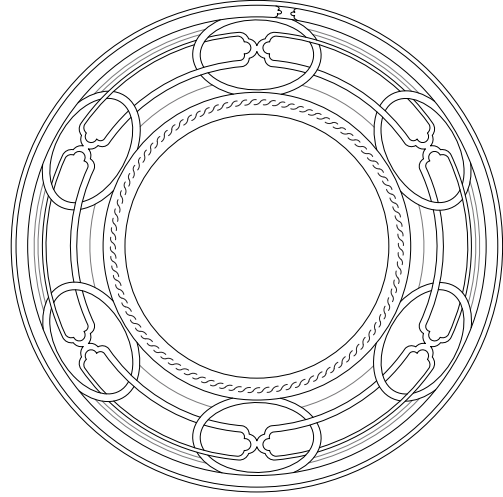

Interior

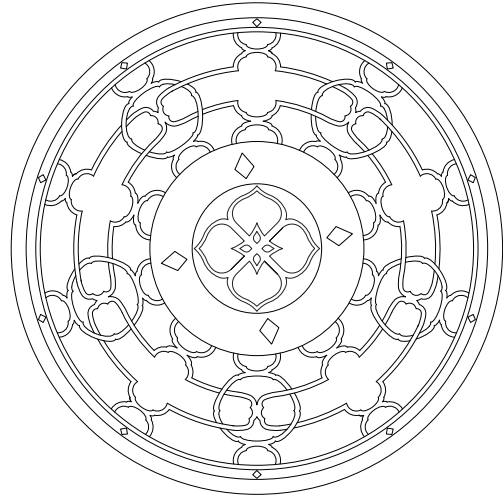

Profile

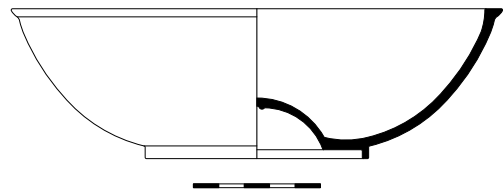

No. 57

Inv. No. MO1232 | Aron 262

Bowl with ring-shaped base, hemispherical umbo,
curved wall, slightly everted rim
Anatolia or Mesopotamia, 16th century

Dimensions: diam. 19.35; h. 5.9 cm, weight 432.1 g

Condition: Poor; interior completely obliterated.

Content: A divinatory-ritual bowl with a rich repertoire of Koranic inscriptions and Shi'i invocations.

Exterior: An upper band features a continuous Koranic inscription on a dotted background. The wall is decorated with six circular cartouches intersected by six *tabulae ansatae* motifs (Fig. 1). The inscriptions in the cartouches are of different shapes and styles. All interstitial spaces are filled with magical alpha-numerical inscriptions on horizontal lines (Fig. 2).



Fig. 1

Interior: The upper band contains 10 cartouches, alternated with rhombus-shaped figures bearing Koranic verses. An inscription enclosed in five cartouches is articulated within a complex grid formed by five circular medallions intersecting with five *tabulae ansatae* and with upper and lower exedras. The surfaces of both the base and the umbo are almost completely worn away.

Comment: This bowl is part of a group of homogeneous objects with similar shape, weight and decorative types. The main characteristic is the use of alternating numerical magic inscriptions and designs in the form of *tabula ansata* with circular or polylobate cartouches (see nos. 55–56, 58–61).

References: Unpublished.



Fig. 2

No. 58

Inv. No. MO1202 | Aron 108



Exterior

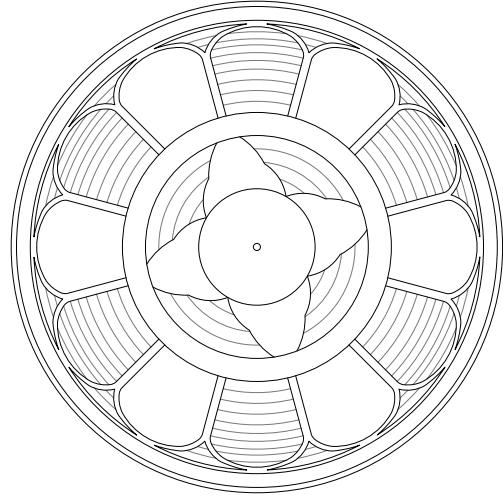

Interior

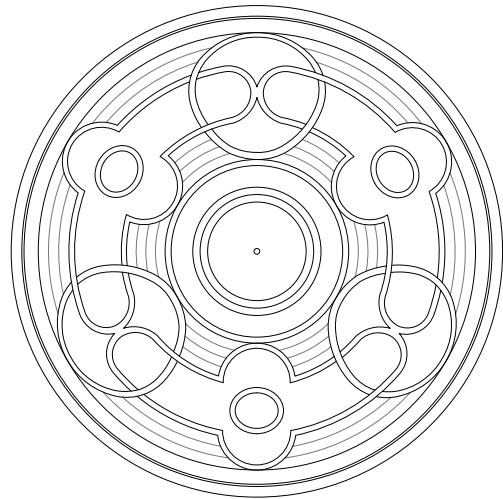

Profile

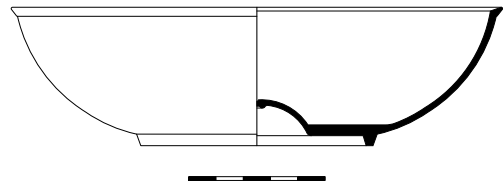

No. 58

Inv. No. MO1202 | Aron 108

Bowl with ring-shaped base, hemispherical umbo;
curved wall, slightly everted rim
Anatolia or Mesopotamia, 16-17th century

Dimensions: diam. 18.04 cm, h. 5.08 cm, 346.2 g

Condition: Fair; interior partially erased, with a hole present.

Content: A divinatory-ritual bowl with a rich repertoire of Koranic inscriptions and Shi'i invocations.

Exterior: An upper band with a continuous Koranic inscription. The wall is decorated with six arched cartouches with a cursive inscription. These cartouches alternate with six arched cartouches which contains the serial repetition of the monogram 'Alī in a squared script (Fig. 1). All interstitial spaces contain the same monogram. Four triangular mountain-shaped motifs are filled with the same monogram. On the base is mentioned the owner 'Arab Khānum bint Jabbāroqlī (Jabbāroghlu; Fig. 2).



Fig. 1

Interior: On the upper wall, a continuous inscription with the *Āyat al-kursī* (the Throne Verse, Kor: 2:255). The wall is decorated with three circular cartouches intersected by three *tabula ansata* motifs containing Koranic inscriptions. The interstitial spaces contains the repetition of the monogram 'Alī. The surfaces around the umbo contains a continuous Koranic inscription. The umbo is almost entirely erased.

Comment: This bowl is part of a group of homogeneous objects with similar shape, weight and decorative types. The main characteristic is the use of alternating numerical magic inscriptions and designs in the form of *tabula ansata* with circular or polylobate cartouches (see nos. 55–57, 59–60).

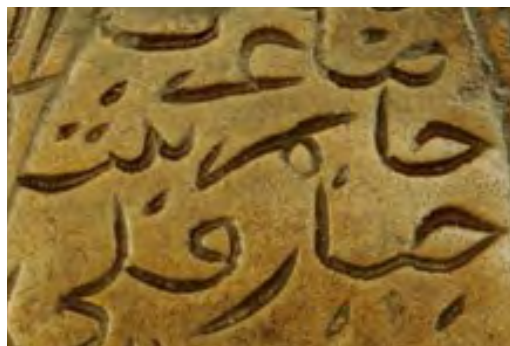

Fig. 2

References: Unpublished.

No. 59

Inv. No. MO1226 | Aron 164



Exterior

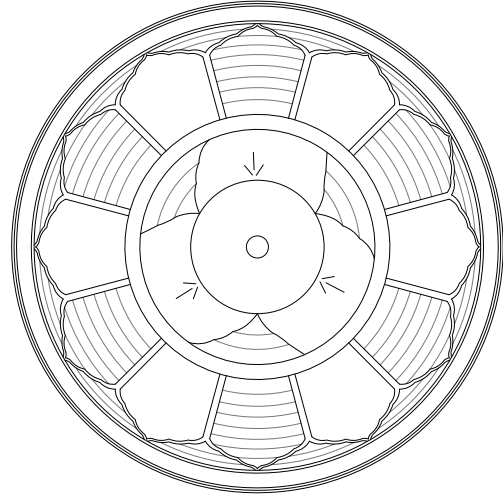

Interior

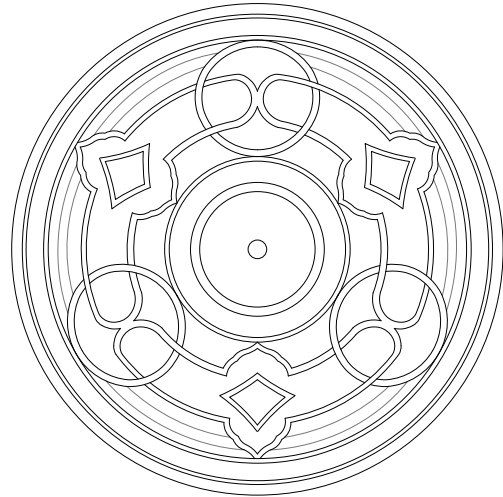

Profile

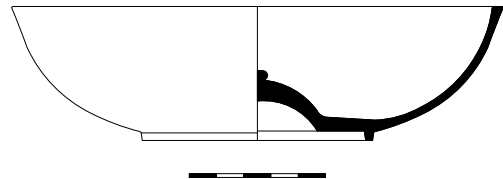

No. 59

Inv. No. MO1226 | Aron 164

Bowl with ring base, hemispherical umbo;
curved wall, straight edge, flat rim
Anatolia or Mesopotamia, 16-17th century

Dimensions: diam. 18.05 cm, h. 4.92 cm, weight 383 g

Condition: Good.

Content: A divinatory-ritual bowl with a rich repertoire of Koranic inscriptions and Shi'i invocations.

Exterior: Below the rim an upper band with a continuous inscription with the *Āyat al-kursī* (the Throne Verse, Kor. 2:255-256). The central part of the wall is decorated with 12 pentagonal “niches”, alternating six magical-numeral texts and six Koranic inscriptions. The interstitial spaces are also filled with magic-numeric inscriptions. Three triangular mountain-shaped motifs filled with numerical inscriptions are arranged in parallel lines on the base (Fig. 1).

Interior: On the upper wall, a continuous inscription formed by the invocation *yā al-Amān yā al-Šamad* (O Safe! O Eternal!), is repeated several times. The central part of the wall is decorated with circular cartouches intersected by *tabula ansata* motifs (Fig. 2). Within these cartouches, the invocation found in the outer pentagonal cartouches is repeated, accompanied by magical-numerical inscriptions. The same texts are also repeated around the umbo and on its surface.

Comment: This bowl is part of a group of homogeneous objects with similar shape, weight and decorative types, albeit with a textual variant consisting of a repeated invocation on the interior surface of the bowl. The main characteristic is the use of alternating numerical magic inscriptions and designs in the form of *tabula ansata* with circular or polylobate cartouches (see nos. 55–58, 60).

References: Unpublished.



Fig. 1



Fig. 2

No. 60

Inv. No. MO1204 | Aron 217

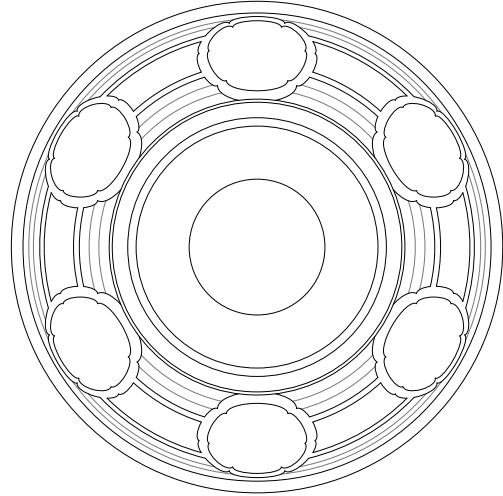
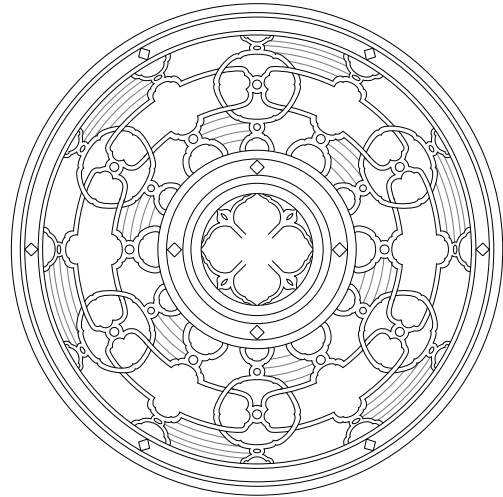
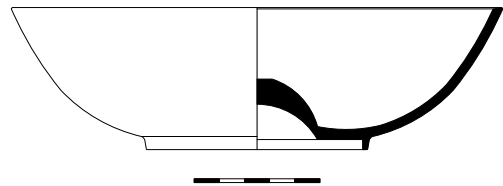
*Exterior**Interior**Profile*

No. 60

Inv. No. MO1204 | Aron 217

Bowl with ring base, hemispherical umbo;
curved wall, straight edge, flat rim
Anatolia or Mesopotamia, 16th century

Dimensions: diam. 17.92 cm, h. 5.07 cm, weight 319 g

Condition: Fair; significant loss of inscriptions due to us.

Content: A divinatory-ritual bowl with a rich repertoire of Koranic inscriptions and Shi'i invocations.

Exterior: An upper band bears the *Āyat al-kursī* (the Throne Verse, Kor. 2:255) in a continuous inscription. The wall is decorated with circular cartouches connected by horizontal bands (Fig. 1). The cartouches contain the continuation of the *Āyat al-kursī*, and within each circle are texts or individual words rendered in larger script. All interstitial spaces feature magical-numerical inscriptions arranged in horizontal lines. On the base, the owner is identified as Muḥammad b. 'Alī.



Fig. 1

Interior: On the upper wall, a Koranic inscription is divided by six rhombuses. Another Koranic inscription, enclosed in five cartouches, is articulated within a complex grid formed by five intersecting circular medallions and six *tabulae ansatae*, with upper and lower exedras. A small human face appears in the centre of each *tabula ansata* (Fig. 2). Around the umbo runs a continuous Koranic inscription, and the umbo itself is decorated with a vegetal motif.

Comment: This bowl is part of a group of homogeneous objects with similar shape, weight and decorative types. The main characteristic is the use of alternating numerical magic inscriptions and designs in the form of *tabula ansata* with circular or polylobate cartouches (nos. 55–59).



Fig. 2

References: Unpublished.

No. 61

Inv. No. MO1239 | Aron 254



Exterior

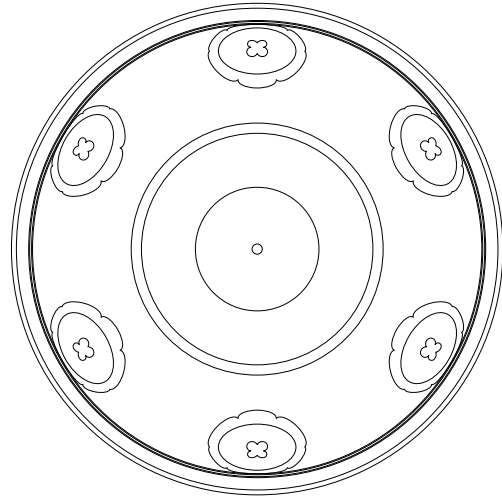

Interior

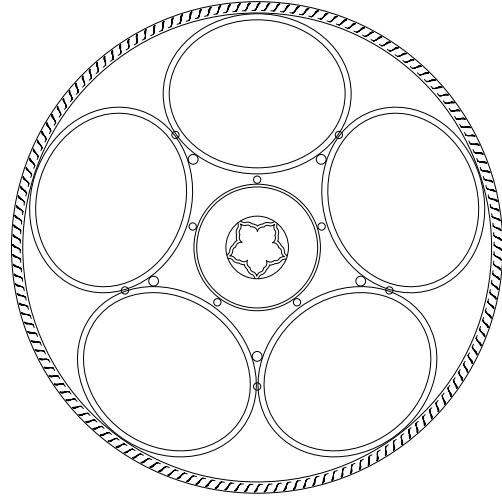

Profile

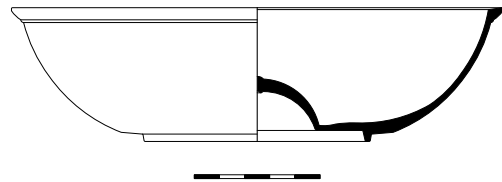

No. 61

Inv. No. MO1239 | Aron 254

Bowl with ring-shaped base, hemispherical umbo;
curved wall, everted horizontal rim
Iran or Mesopotamia, 17th century

Dimensions: diam. 19.55, h. 5.32 cm, weight 445 g

Condition: Good.

Content: A divinatory-ritual bowl with a rich repertoire of Koranic inscriptions and Shi'i invocations.

Exterior: An upper band bearing a continuous inscription invoking the *Chahārdah ma'sūm* ("The Fourteen Infallibles"). The wall is decorated with six roundels, each containing a flower-shaped design formed by four monograms of 'Alī interlacing in the centre (Fig. 1). The interstitial spaces contain Shi'i prayers, which also appear alongside Koranic texts around the base and on the outer surface of the umbo. The writing is always carefully vocalised.

Interior: The entire surface of the interior is dominated by six large roundels (Fig. 2), extending from just below the rim down to the umbo. Inside them are prayers and invocations, which are repeated in the interstitial spaces and on the umbo, at the top of which stands out a flower design (Fig. 3).

Comment: This bowl shows a rare pattern, and is distinguished by the accuracy of the meticulously vocalised cursive script. Although certainly Shi'i-made, it differs from contemporary Iranian examples indicating a probable provenance from Iraq.

References: Unpublished.



Fig. 2

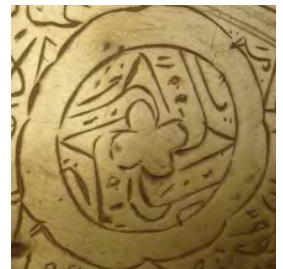

Fig. 1



Fig. 3

No. 62

Inv. No. MO1228 | Aron 286



Exterior

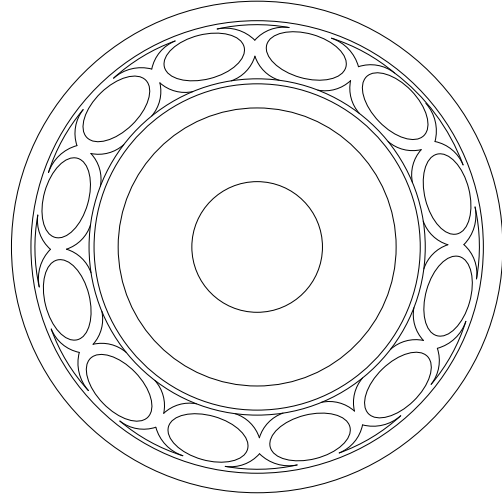

Interior

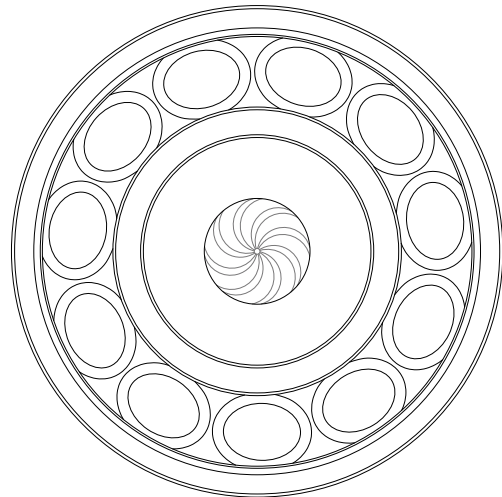

Profile

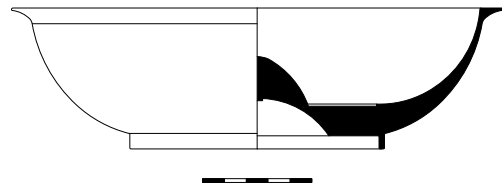

No. 62

Inv. No. MO1228 | Aron 286

Bowl with ring base, hemispherical umbo;
curved wall, everted horizontal rim
Iran, 17th century

Dimensions: diam. 22.5 cm, h. 6.45 cm, weight 785 g

Condition: Fair; some damages along the rim on the body of the bowl.

Content: A divinatory-ritual bowl with a rich repertoire of Koranic inscriptions and Shi'i invocations.

Exterior: On the outer surface of the rim is a continuous Koranic text. Beneath the rim is an inscription within cartouches connected by tasselled knots (Fig. 1). Below is a band consisting of 12 medallions. The text in the medallions contains Koranic verses. The inscription continues in the interstitial spaces. Around the umbo a continuous Koranic inscription.

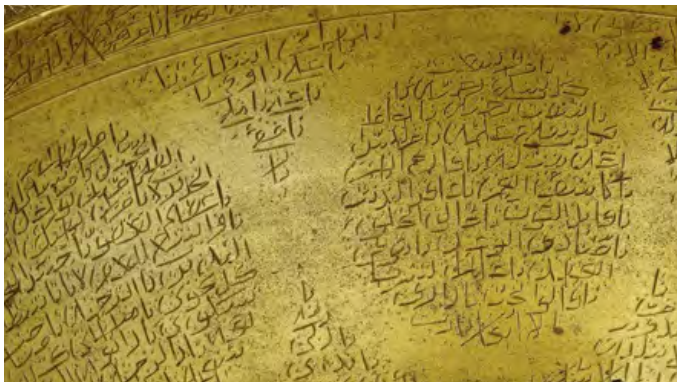

Fig. 1

Interior: The same pattern is repeated in the interior. Around the umbo the *Nādi 'Aliyyan* ("Call upon 'Alī"). The umbo is decorated with a Koranic inscription arranged in vertical radiated bands (Fig. 2).

Comment: This bowl exemplifies the popular imitation of more refined models, as indicated by the repetition of motifs inside and outside and by the crude, rudimentary script, which point to a second-rate production.

References: Unpublished.



Fig. 2

No. 63

Inv. No. MO1196 | Aron 138



Exterior

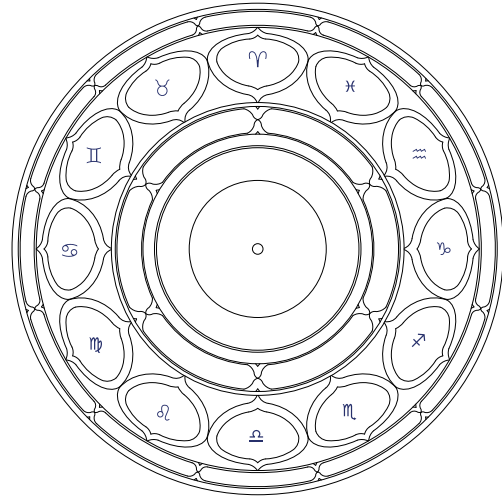

Interior

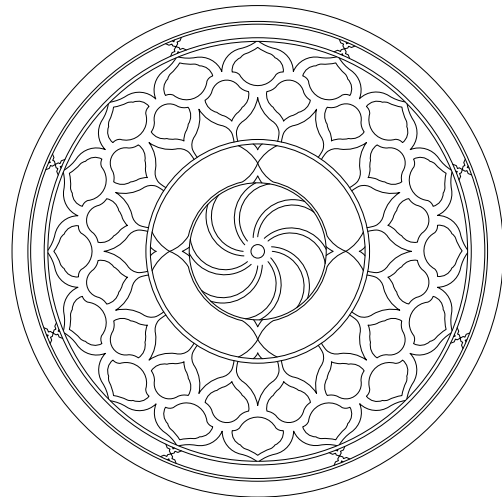

Profile

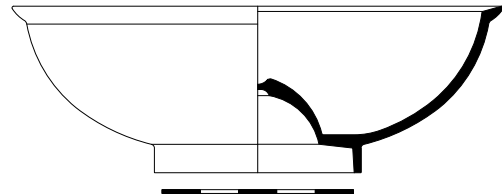

No. 63

Inv. No. MO1196 | Aron 138

Bowl with ring base, hemispherical umbo with grooves;
curved wall, horizontal everted rim
Iran, Fārs, first half of the 17th century

Dimensions: diam. 12.84 cm, h. 4.35 cm, weight 228 g

Condition: Good.

Content: A divinatory-ritual bowl with a rich repertoire of Koranic and Shi'ī inscriptions.

Exterior: On the outer surface of the rim a continuous Koranic inscription. Below the rim, into 12 oval cartouches, the *Chahārdah ma'ṣūm* ("The Fourteen Infallibles") with their attributes. The wall is decorated with 12 oval medallions with pointed ends, each containing one of the 12 zodiacal sign (Fig. 1). Around the base, a second epigraphic band consists of six cartouches containing Koranic verses. On the outer surface of the umbo an inscription bears the name of the owner Muḥammad Rafī' son of Muḥammad Zamān 'Izzābādī ('Izzābādī is a typical name of the Fārs region).



Fig. 1

Interior: On the inner surface of the rim is continuous inscription with the *Āyat al-kursī* (the Throne Verse; Kor. 2:255-256). An inscription with a prayer appears below the rim, set within eight polylobate cartouches. The wall is decorated with 64 lobate cartouches containing the *Asmā' al-ḥusnā* ("The Beautiful Names [of God]") and other Koranic texts which continue in the interstitial spaces. Around the umbo, four cartouches contain the *Nādi 'Aliyyan* ("Call upon 'Alī") written in a profiled *nasta'liq* script. The umbo contains an inscription arranged within eight wavy bands and has a small embedded turquoise at its top (Fig. 2).

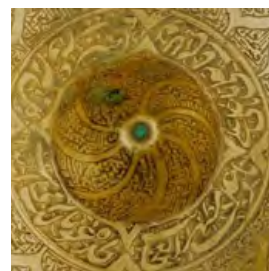

Comment: This small bowl belongs to a group sharing epigraphic, decorative, and formal traits. The umbo bears the *Nādi 'Aliyyan* in *nasta'liq* within a dense layout of minute script. Comparable bowls are signed or dated to the first half of the 17th century and likely originate from Fārs (see also nos. 64–69).

References: Unpublished.

Fig. 2

No. 64

Inv. No. MO1197 | Aron 139



Exterior

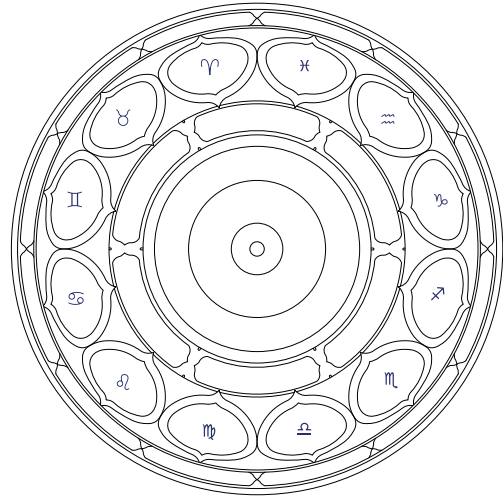

Interior

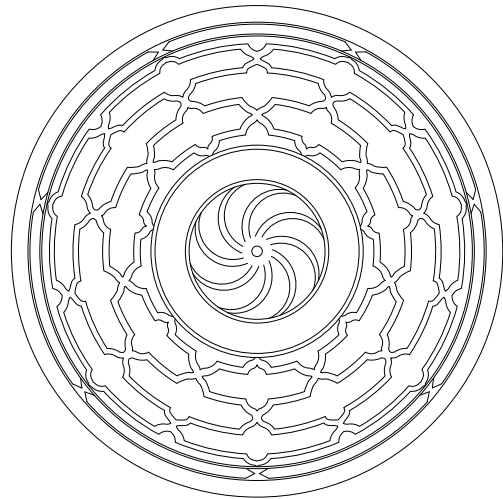

Profile

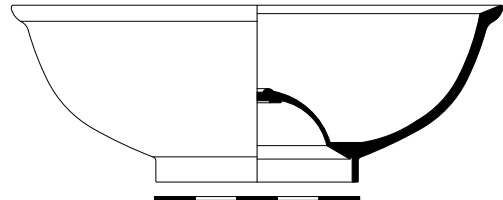

No. 64

Inv. No. MO1197 | Aron 139

Bowl with ring base, hemispherical umbo with grooves;
curved wall, horizontal everted rim
Iran, Fārs, 1051/1641-42

Dimensions: diam. 11.98 cm, h. 4.31 cm, weight 251.2 g

Condition: Good.

Content: A divinatory-ritual bowl with a rich repertoire of Koranic and Shi'i inscriptions.

Exterior: On the outer surface of the rim a continuous inscription, containing the *Asmā' al-ḥusnā* ("The Beautiful Names [of God]"). Below the rim, into 12 oval cartouches the *Chahārdah ma'sūm* ("The Fourteen Infallibles") with their attributes. 12 pointed oval medallions decorate the wall, each bearing a zodiacal sign (Fig. 1). Around the base, a second epigraphic band consists of six cartouches containing Koranic verses. On the outer surface of the umbo an inscription with a distich, the name of the craftsman and the date "Taḳī Šīrāzī during the months of the year thousand and fifty-one of the Hijra of the Prophet, the peace of God on Him and his family. Year 1051 (1641-42)" (Fig. 2).

Interior: On the inner surface of the rim is a continuous inscription with the *Āyat al-kursī* (the Throne Verse; Kor. 2:255-256). It continues below the rim into 6 oval cartouches. The wall is decorated with 35 polylobate cartouches containing various Koranic verses. Around the umbo, a continuous inscription contains the *Nādī 'Aliyyan* ("Call upon 'Alī") written in a profiled *nasta'liq* script. The umbo contains an inscription arranged within eight wavy bands and has a small embedded turquoise at its top (Fig. 3).

Comment: This small bowl belongs to a group sharing epigraphic, decorative, and formal traits. The umbo bears the *Nādī 'Aliyyan* in *nasta'liq* within a dense layout of minute script. Comparable bowls are signed or dated to the first half of the 17th century and likely originate from Fārs (see also nos. 63, 65-69).

References: Bernardini in press.



Fig. 1



Fig. 2

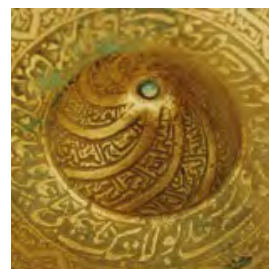

Fig. 3

No. 65

Inv. No. MO1194 | Aron 430



Exterior

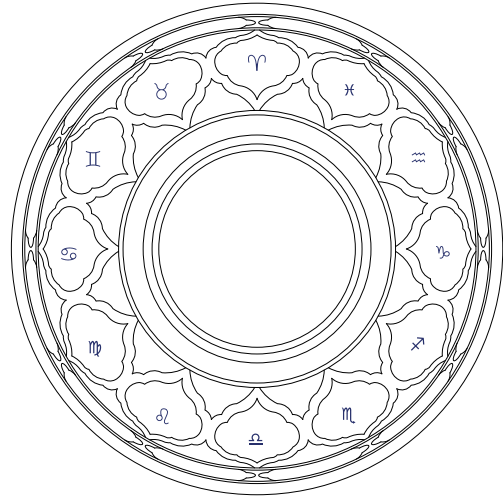

Interior



Profile

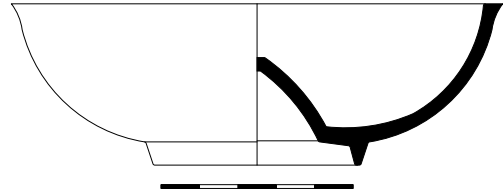

No. 65

Inv. No. MO1194 | Aron 430

Bowl ring base, hemispherical umbo with grooves;
curved wall, horizontal and slightly everted rim
Iran, Fārs, 17th century

Dimensions: diam. 12.70 cm, h. 4.1 cm

Condition: Good.

Content: A divinatory-ritual bowl with a rich repertoire of Koranic and Shi'i inscriptions.

Exterior: On the outer surface of the rim a continuous inscription, the *Asmā' al-ḥusnā* ("The Beautiful Names [of God]"). Below the rim, into 12 oval cartouches the *Chahārdah ma'ṣūm* ("The Fourteen Infallibles") with their attributes. The wall is decorated with 12 oval medallions with pointed ends with the 12 zodiacal signs (Fig. 1). Around the base, a second epigraphic band consists of six cartouches containing Koranic verses.



Fig. 1

Interior: On the inner surface of the rim is a continuous inscription with the *Āyat al-kursī* (the Throne Verse; Kor. 2:255-256). Below the rim an inscription into six oval cartouches. The wall is decorated with 13 polylobate cartouches containing various Koranic verses (Fig. 2). Around the umbo, a continuous inscription contains the *Nādi 'Aliyyan* ("Call upon 'Alī") written in a profiled *nasta'liq* script.



Fig. 2

Comment: This small bowl belongs to a group sharing epigraphic, decorative, and formal traits. The umbo bears the *Nādi 'Aliyyan* in *nasta'liq* within a dense layout of minute script. Comparable bowls are signed or dated to the first half of the 17th century and likely originate from Fārs (see also nos. 63–64, 66–69).

References: Bernardini in press.

No. 66

Inv. No. MO1195 | Aron 147



Exterior

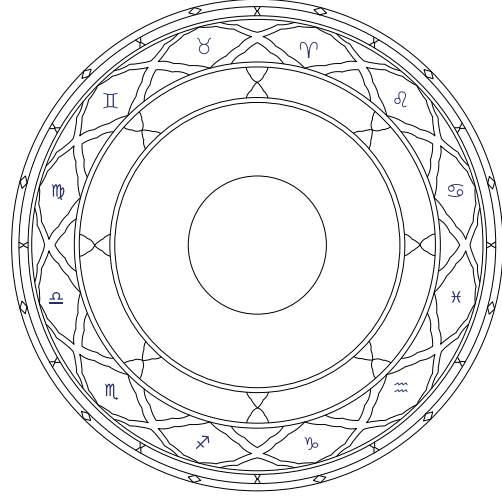

Interior

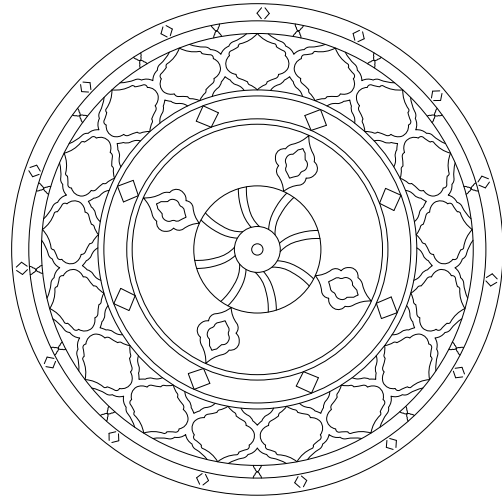

Profile

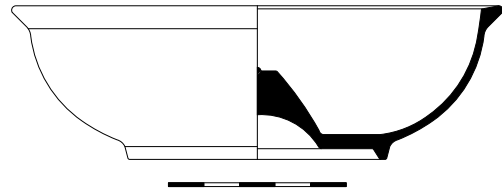

No. 66

Inv. No. MO1195 | Aron 147

Bowl with ring base, hemispherical umbo with flat top;
curved wall, horizontally everted rim
Iran, 17th-18th century

Dimensions: diam. 15.03 cm, h. 4.95 cm, weight 370.9 g

Condition: Good.

Content: A divinatory-ritual bowl with a rich repertoire of Koranic and Shi'i inscriptions.

Exterior: On the outer surface of the rim a continuous inscription, containing the *Āyat al-kursī* (the Throne Verse; Kor. 2:255-256). Below the rim, into 12 oval cartouches, the *Chahārdah ma'šūm* ("The Fourteen Infallibles") with their attributes. The wall is decorated with 12 oval medallions with pointed ends with the 12 Zodiacal signs (Fig. 1). Around the base, a second epigraphic band consists of six cartouches containing Koranic inscriptions.



Fig. 1

Interior: On the inner surface of the rim is a Koranic inscription enclosed in 15 cartouches. Below another Koranic inscription. In the central section of the wall 15 almond-shaped medallions with a Koranic inscription. Around the umbo, a continuous inscription contains the *Nādi 'Aliyyan* ("Call upon 'Alī"). The umbo bears an inscription arranged within six wavy bands and has a small embedded turquoise at its top (Fig. 2).

Comment: This small bowl is a later evidence of a group united by epigraphic and decorative aspects as well as form, including the inscription around the umbo containing the *Nādi 'Aliyyan* as well as the dense epigraphic layout in minute characters. Several such bowls are signed or dated around the first half of the 17th century and various elements point to their provenance from Fars (see also nos. 63–65, 67–69).

References: Bernardini in press.



Fig. 2

No. 67

Inv. No. MO1193 | Aron 256



Exterior

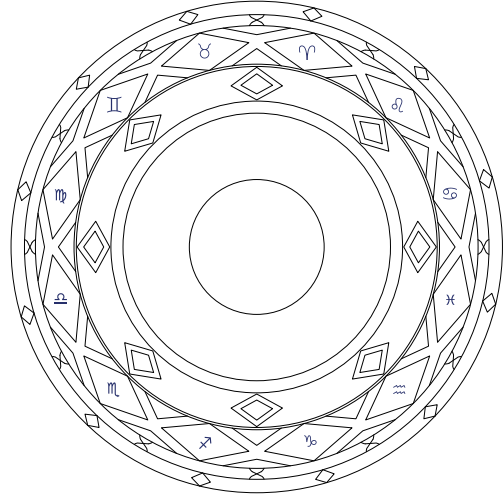

Interior

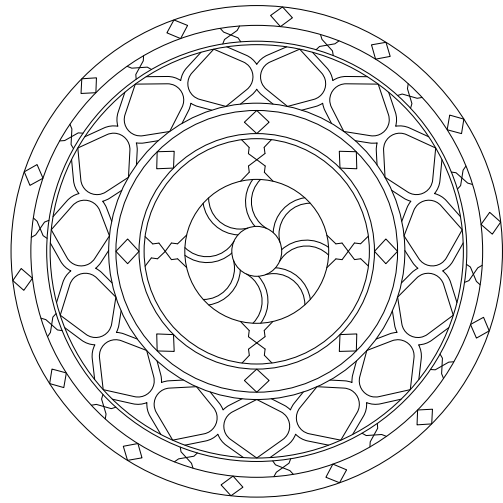

Profile

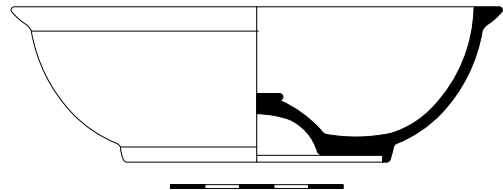

No. 67

Inv. No. MO1193 | Aron 256

Bowl with ring base, hemispherical umbo with flat top;
curved wall, horizontal everted rim
Iran, Fārs, 17th century

Dimensions: diam. 14.24 cm, h. 4.5 cm, weight 492.9 g

Condition: Good.

Content: A divinatory-ritual bowl with Koranic and Shi‘i inscriptions.

Exterior: On the outer surface of the rim is an inscription with the *Āyat al-kursī* (the Throne Verse, Kor. 2:255-256) in 12 cartouches. Below the rim, into 12 oval cartouches, the *Chahārdah ma ‘šūm* (“The Fourteen Infallibles”) with their attributes. The wall is decorated with 12 squared cartouches each bearing a zodiacal sign (Fig. 1). Around the base, a second epigraphic band consists of eight cartouches containing Koranic inscriptions.



Fig. 1

Interior: On the inner surface of the rim is an inscription with the *Āyat al-kursī*. Below the rim a Koranic inscription in 12 cartouches. The lower part of the wall is decorated with 15 polylobate cartouches containing various Koranic Surahs. Around the umbo, a continuous inscription contains the *Nādi ‘Aliyyan* (“Call upon ‘Alī”). The umbo bears an inscription arranged within eight wavy bands (Fig. 2).

Comment: This small bowl belongs to a group sharing epigraphic, decorative, and formal traits. The umbo bears the *Nādi ‘Aliyyan* in *nasta‘līq* within a dense layout of minute script. Comparable bowls are signed or dated to the first half of the 17th century and likely originate from Fārs (see also nos. 63–66, 68–69).

References: Bernardini in press.



Fig. 2

No. 68

Inv. No. MO1248 | Aron 245



Exterior

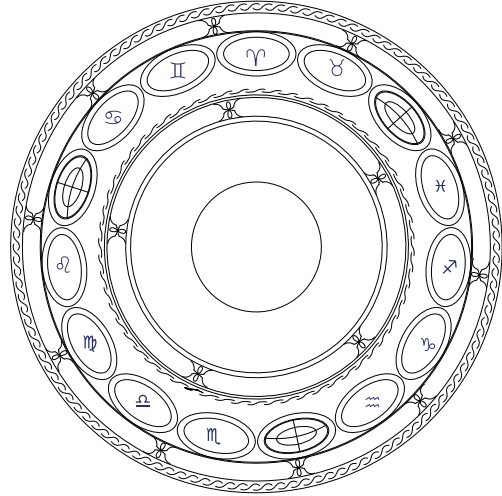

Interior

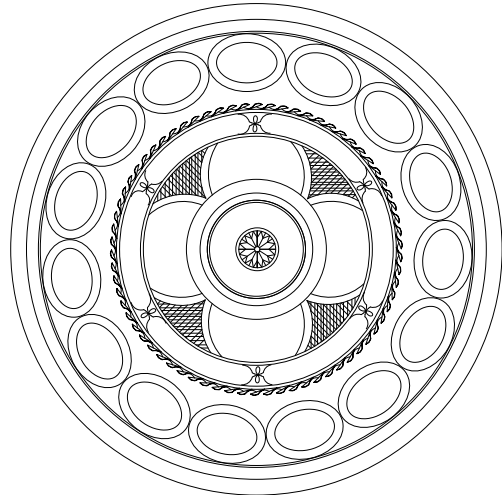

Profile

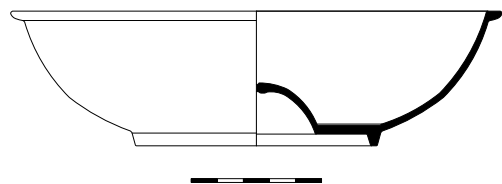

No. 68

Inv. No. MO1248 | Aron 245

Bowl with ring base, hemispherical umbo;
curved wall, everted horizontal rim
Ottoman Syria or Iraq, 17th century

Dimensions: diam. 18.87 cm, h. 5.17 cm, weight 533 g

Condition: Fair; the interior is partially worn.

Content: A divinatory-ritual bowl with a rich repertoire of Koranic inscriptions, Shi'i inscriptions, and invocations. *Yā Kāfī, yā Shāfī* type.

Exterior: An upper epigraphic band, containing the *Chahārdah ma'sūm* ("The Fourteen Infallibles"), divided into eight cartouches connected by a bow knot, a feature characteristic of all these bowls (Fig. 2). The wall is decorated with 15 roundels—each bearing a zodiacal sign—, and three magic numeric diagrams (Fig. 1). Around the base, a second epigraphic band consists of six cartouches with the same characteristics as the upper one, containing Koranic verses.

Interior: The upper section features a continuous Koranic band, which extends into 15 roundels below. Magical numerical inscriptions appear in the interstitial spaces, four cartouches around the umbo contain the invocations: "O Judge of needs!" (*yā Qādī al-ḥājjāt*); "O Sufficiency of necessary things!" (*yā Kāfī al-muḥimmat*); "O Sublime degree!" (*yā Raḥī' al-darajāt*); "O Prince of good deeds!" (*yā Walī al-ḥasanāt*). The umbo is decorated with four lines containing a magical numerical inscription, an invocation and a star motif at the top (Fig. 3).

Comment: Part of a group sharing epigraphic and decorative features, this bowl displays a four-sided pattern of cartouches around the umbo with similar inscriptions. The repeated formula *yā Kāfī yā Shāfī* points to a homogeneous, well-known group (see also nos. 69 and 70).

References: Unpublished.



Fig. 1



Fig. 2



Fig. 3

No. 69

Inv. No. MO1211 | Aron 204



Exterior

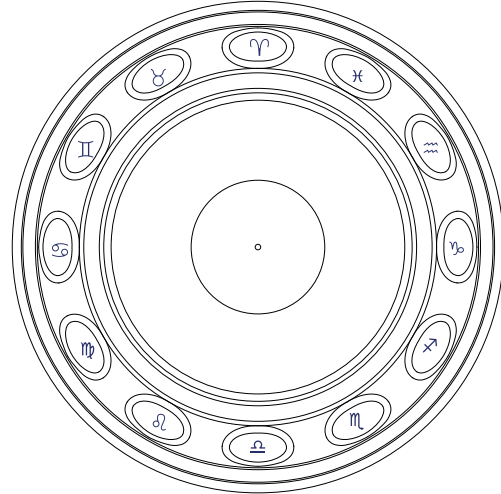

Interior



Profile

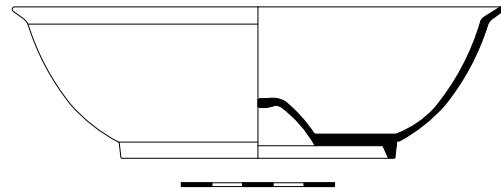

No. 69

Inv. No. MO1211 | Aron 204

Bowl with ring base, hemispherical umbo with flat top,
curved wall, horizontal everted rim
Syria or Mesopotamia, 19th century

Dimensions: diam. 16.04 cm, h. 4.94 cm, weight 492 g

Condition: Good.

Content: A divinatory-ritual bowl with a rich repertoire of Koranic inscriptions, Shi'i inscriptions, and invocations. *Yā Kāfī, yā Shāfī* type.

Exterior: Below the rim is the *Chahārdah ma'sūm* ("The Fourteen Infallibles") in a continuous inscription. On the wall are the 12 signs of the Zodiac (Fig. 1). Around the base, a Koranic inscription.



Fig. 1

Interior: Below the rim a continuous inscription with the *Āyat al-kursī* (the Throne Verse, Kor. 2:255). On the wall the same pattern of the exterior is repeated with 44 "clove" cartouches containing a Koranic inscription. Around the base a continuous Koranic inscription. Four cartouches around the umbo contain the invocations of the type *yā Kāfī yā Shāfī*. On the umbo are two magic numerical inscriptions on two parallel lines. A flower design adorns the truncated umbo.

Comment: Part of a group sharing epigraphic and decorative features, this bowl displays a four-sided pattern of cartouches around the umbo with similar inscriptions. The repeated formula *yā Kāfī yā Shāfī* points to a homogeneous, well-known group (see nos. 68, 70, 77–78, 83).

References: Unpublished.

No. 70

Inv. No. MO1237 | Aron 255

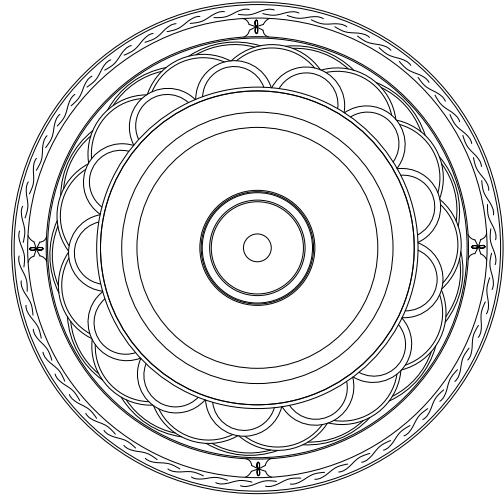
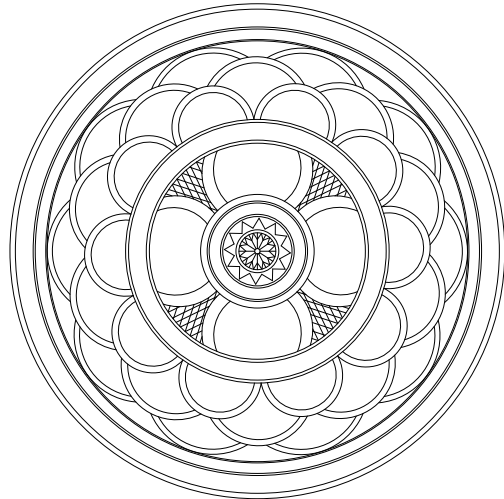
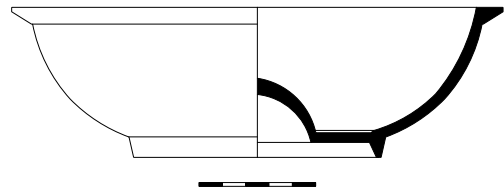
*Exterior**Interior**Profile*

No. 70

Inv. No. MO1237 | Aron 255

Bowl with ring base, hemispherical umbo;
curved wall, everted rim. Pendant attached
Iran, 1171/1757-58

Dimensions: diam. 21.1 cm, h. 6.44 cm, weight 934 g

Condition: Good.

Content: A divinatory-ritual bowl with a rich repertoire of Koranic inscriptions, and Shi'ī invocations. *Yā Kāfī*, *yā Shāfī* type.

Exterior: An upper epigraphic band, containing the *Chahārdah ma'sūm* ("The Fourteen Infallibles"), arranged in four cartouches connected by a bow knot, a feature characteristic of all these bowls. The wall is decorated with 39 "wedge" cartouches where the text of the *Chahārdah ma'sūm* continues. Around the base, a second continuous Koranic band. The drop-shaped pendant was used to hang the bowl (Fig. 1).

Interior: A continuous Koranic text runs on the surface of the rim, ending with the date [1]171 (1757-58; Fig. 2). Below the rim a continuous inscription contains the *Āyat al-kursī* (the Throne Verse, Kor. 2:255). The surface of wall is decorated with 30 "wedge" cartouches containing Koranic texts. Around the umbo, a continuous Koranic inscription surrounds four cartouches with invocations: "O Clear!" (*yā Shāfī*); "O Sufficiency of necessary things!"; "O Judge of needs!" (*yā Qādī al-hājjāt*); "O Sufficiency /of necessary things!" (*yā Kāfī /al-muhimmat*). The umbo bears an engraved star (Fig. 3).

Comment: This bowl is a late example of the *yā Kāfī*, *yā Shāfī* group (see nos. 68–69, 77-78, 83).

References: Unpublished.



Fig. 1



Fig. 2



Fig. 3

No. 71

Inv. No. MO1223 | Aron 261



Exterior

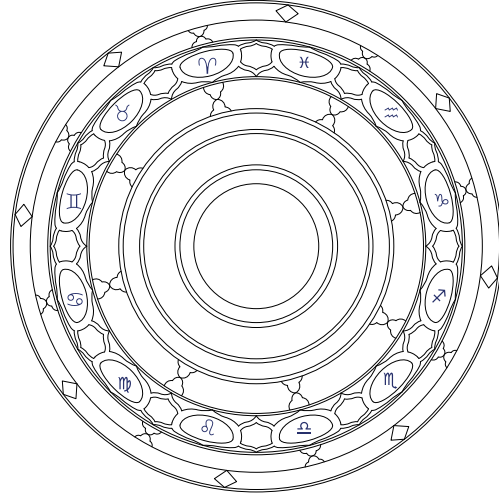

Interior

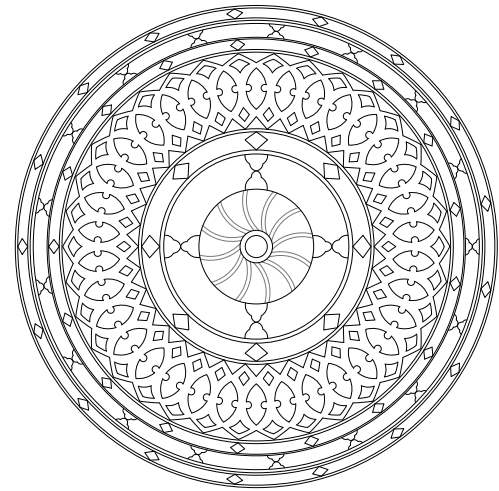

Profile

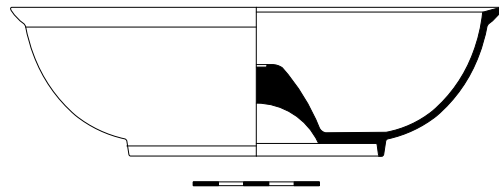

No. 71

Inv. No. MO1223 | Aron 261

Bowl with ring base, hemispherical umbo with flat top,
curved wall, oblique and flat rim
Iran, 18-19th century

Dimensions: diam. 19.5 cm; h. 5.9 cm; weight 693 g

Condition: Good.

Content: A divinatory-ritual bowl with a rich repertoire of Koranic and Shi'i inscriptions.

Exterior: 12 cartouches on the rim bearing Koranic verses. 11 cartouches on the upper band with a Koranic verse. The wall features 12 rhomboidal epigraphic medallions, alternating with twelve Zodiac signs (Fig. 1). Eight cartouches in the band around the base contain Koranic inscriptions.



Fig. 1

Interior: 16 cartouches on the rim contain the *Chahārdah ma'sūm* ("The Fourteen Infallibles"). Below, a band consists of 16 cartouches containing Koranic inscriptions. At the centre, 34 almond-shaped cartouches are formed by the intersection of an upper and a lower grid of 34 lozenge-shaped cartouches, also containing Koranic inscriptions. Eight cartouches surround the base, while four cartouches around the umbo bear the "Call upon 'Alī".

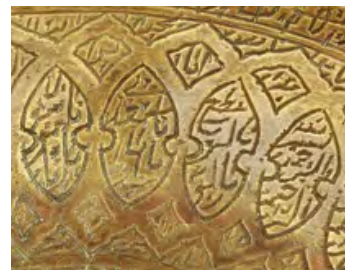

Fig. 2

Comment: This bowl is a late example from a group of bowls that enjoyed particular popularity during the Safavid period. Executed in a rudimentary manner, it appears to originate from provincial areas of India or Iran. This attribution is further supported by the inscription around the umbo, which contains the *Nādi 'Aliyyan*.

References: Unpublished.

No. 72

Inv. No. MO1207 | Aron 391



Exterior

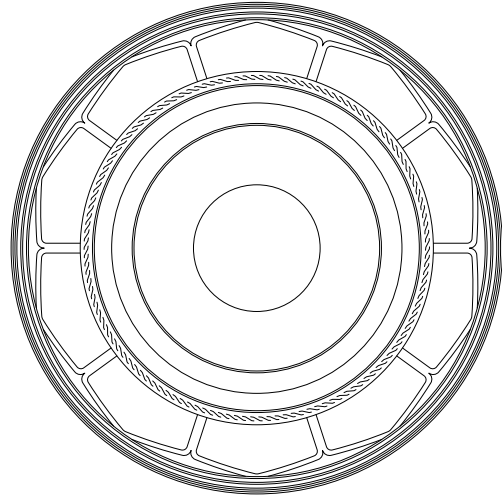

Interior

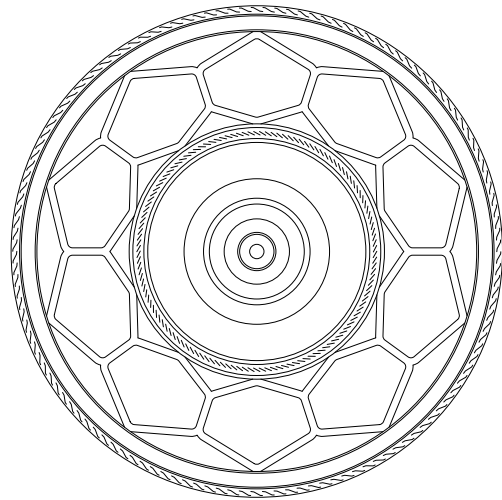

Profile

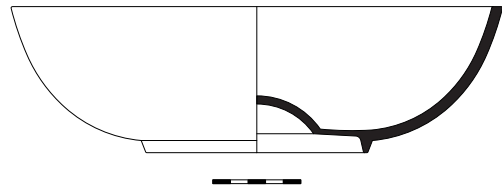

No. 72

Inv. No. MO1207 | Aron 391

Bowl with ring base, hemispherical umbo,
curved wall, straight edge, flat rim
India, 17th century

Dimensions: diam. 18.40 cm, h. 5.25 cm, weight 585 g

Condition: Good

Content: A divinatory-ritual bowl with a repertoire of Koranic verses and invocations.

Exterior: An upper band bears a continuous Koranic inscription. The wall is decorated with a sequence of 10 pentagonal cartouches containing Koranic inscriptions (Fig. 1). Around the umbo a continuous Koranic inscription on two lines.

Interior: On the upper wall, a continuous inscription with the *Āyat al-kursī* (the Throne Verse, Kor.: 2:255). In the centre of the wall, 10 hexagonal cartouches containing invocations (Fig. 2). In the interstitial spaces at the top of the hexagons are magic numerical inscriptions.

Comment: This bowl exhibits Indian characteristics in terms of shape, execution technique, and decorative motifs.

References: Unpublished.



Fig. 1



Fig. 2

No. 73

Inv. No. MO1224 | Aron 289



Exterior

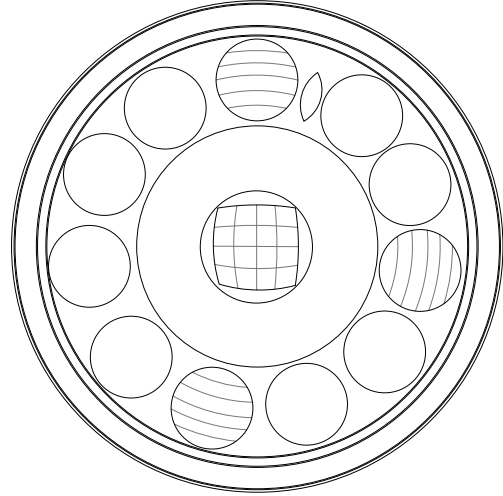

Interior

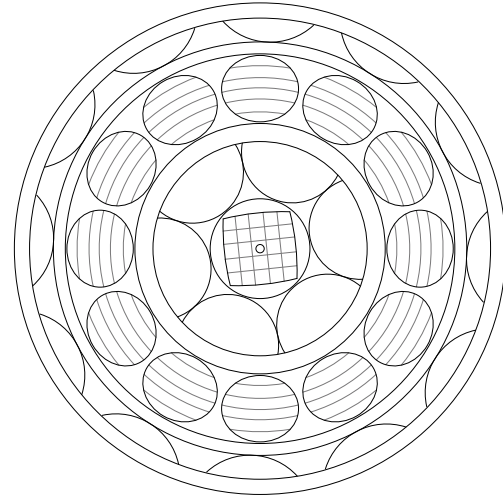

Profile

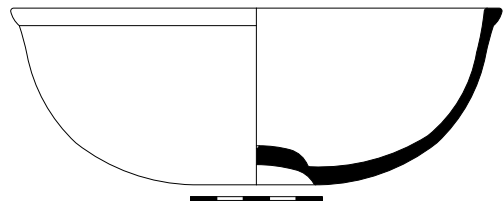

No. 73

Inv. No. MO1224 | Aron 289

Bowl with flat base, hemispherical umbo,
curved wall, swollen edge, flat rim
Anatolia or Mesopotamia, 18th century

Dimensions: diam. 18.64 cm, h. 6.7 cm, weight 675.5 g

Condition: Poor; most of the text is illegible due to extensive wear.

Content: A divinatory-ritual bowl with a rich repertoire of Koranic inscriptions and Shi'i invocations.

Exterior: The upper part of the wall bears a continuous inscription in five horizontal lines, oriented inversely to the surface of the bowl (Fig. 1). The inscription consists of an invocation that includes the “Beautiful Names” of God and the prophets, and venerates the *Āl-i ma'sūm*, i.e. the family of 'Alī. Strongly atypical. Below are 12 circular medallions with 24 upper and lower interstitial spaces. The medallions contain alphanumeric inscriptions, which are illegible, as is another epigraphic band situated below. The umbo features a 4 × 4 numeric square (Fig. 2).



Fig. 1

Interior: In the middle band, there are 12 circular medallions with 24 interstitial spaces between them. The inscription is illegible. Around the base are 15 exedra-shaped medallions with 15 interstitial spaces containing the “Beautiful Names” of God, which differ from the canonical ones.

Comment: This bowl represents a rare example of its type. The inverted inscription is also found in other examples. The form is rather atypical, although the absence of a foot and certain other features suggest a connection with the Anatolian context.

References: Unpublished.



Fig. 2

No. 74

Inv. No. MO1233 | Aron 317



Exterior

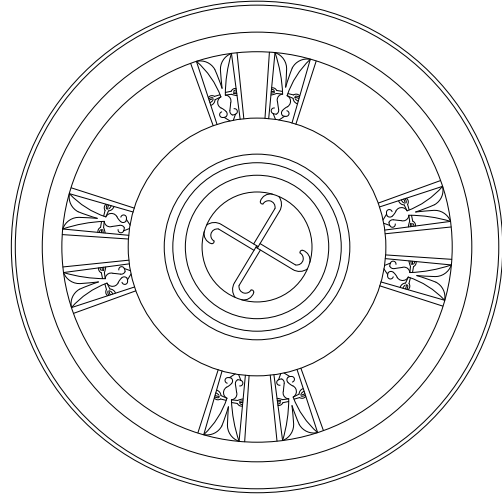

Interior

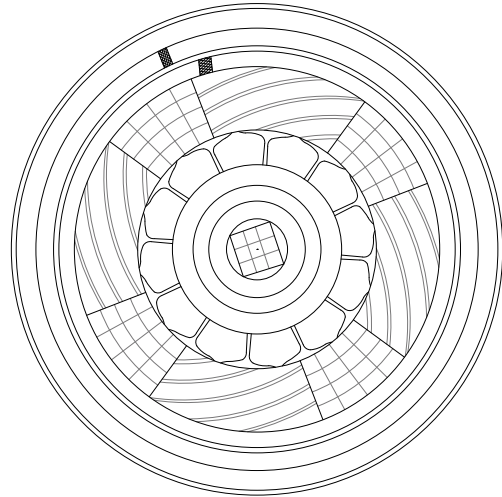

Profile

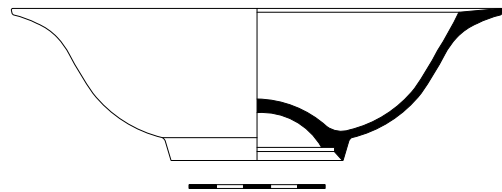

No. 74

Inv. No. MO1233 | Aron 317

Bowl with ring base, hemispherical umbo,
flared wall, horizontally everted rim
India, 18th century

Dimensions: diam. 18.1 cm, h. 5.6 cm, weight 546 g

Condition: Medium; some metal fractures and areas of erosion.

Content: A divinatory-ritual bowl with Koranic inscriptions and various depictions of the sword of *Dhū'l-faqār*.

Exterior: An inscription on the outer surface of the rim continues below with the *Āyat al-kursī* (the Throne Verse, Kor. 2:255). Below, a wide band characterised by square panels houses large-format epigraphs, with the motto *Lā fatā illā 'Alī lā ṣayf illā Dhū'l-faqār* (There is no hero but 'Ali, no sword but *Dhū'l-faqār*) and depictions of eight two-bladed swords of *Dhū'l-faqār* (Fig. 1). A continuous Koranic inscription surrounds the ring of the base. Monograms with invocations appear on the outer surface of the umbo.

Interior: On the rim's surface, inscribed in two lines, is a Koranic quotation accompanied by the magical formula *Kafkafiyya*. Below the rim runs a continuous Koranic inscription. At the centre of the inner wall are four square panels featuring inscriptions arranged along five diagonal lines (Fig. 2), alongside four squares containing 16 numbered boxes each. Around the base, 12 niche-shaped cartouches display magical numerical inscriptions. The umbo is decorated with a "fire square" composed of nine smaller squares at its apex.



Fig. 1



Fig. 2

Comment: This type of Indo-Persian craftsmanship, marked by Shi'ite influences, is distinguished by the depiction of the sword of *Dhu'l-Faqār* and the inclusion of magical inscriptions such as magic squares (see also nos. 75 and 76).

References: Unpublished.

No. 75

Inv. No. MO1231 | Aron 240

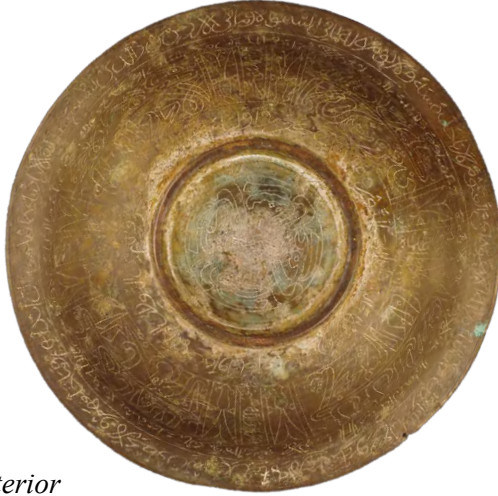
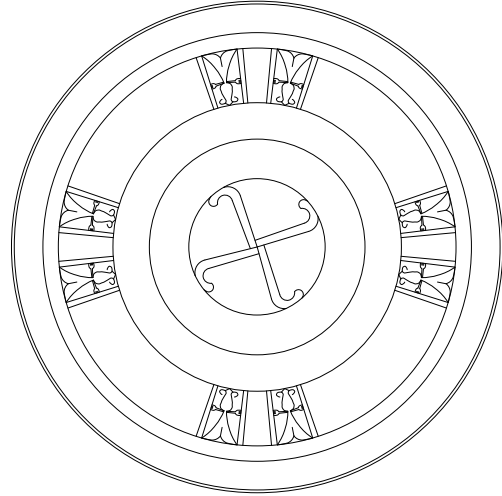
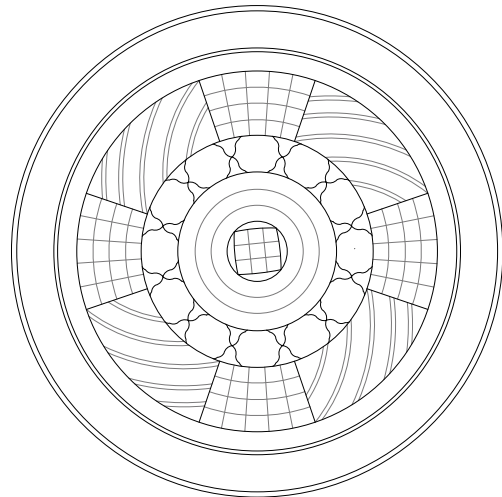
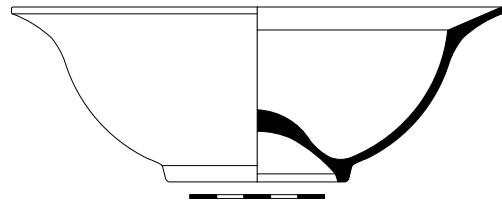
*Exterior**Interior**Profile*

No. 75

Inv. No. MO1231 | Aron 240

Bowl with ring base, hemispherical umbo,
flared wall, horizontally everted rim
India, 18th century

Dimensions: diam. 18.24 cm, h. 6.49 cm, weight 436 g

Condition: Good.

Content: A divinatory-ritual bowl with Koranic inscriptions and various depictions of the sword of *Dhū'l-faqār*.

Exterior: A continuous inscription on the outer surface of the rim is followed by the *Āyat al-kursī* (the Throne Verse, Kor. 2:255). Beneath this, a wide band composed of square panels contains large-format epigraphs bearing the motto *Lā fatā illā 'Alī lā ṣayf illā Dhū'l-faqār* ("There is no hero but 'Alī, no sword but *Dhū'l-faqār*"), together with depictions of eight two-bladed swords of *Dhū'l-faqār* (Fig. 1). A continuous Koranic inscription surrounds the ring of the base. Four monograms with invocations appear on the outer surface of the umbo (Fig. 2).

Interior: On the surface of the rim is a Koranic quotation with the magic formula *Kaṣṣafīyya*. Below the rim a continuous Koranic inscription. In the centre of the wall is a series of four square panels containing inscriptions on five diagonal lines, and four squares with 16 boxes containing numbers. 12 niche panels cartouches with magical numerical inscriptions are arranged around the base. The umbo has a "fire square" with nine squares at its top (Fig. 3).

Comment: This type of Indo-Persian workmanship, distinguished by its style and Shi'ite elements, is characterized by depictions of the sword of *Dhū'l-Faqār* and by the presence of magical inscriptions, including magic squares (see also nos. 74 and 76).

References: Unpublished.



Fig. 1

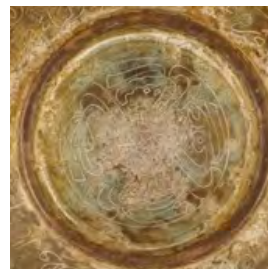

Fig. 2

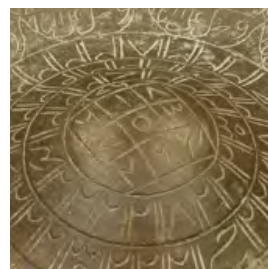
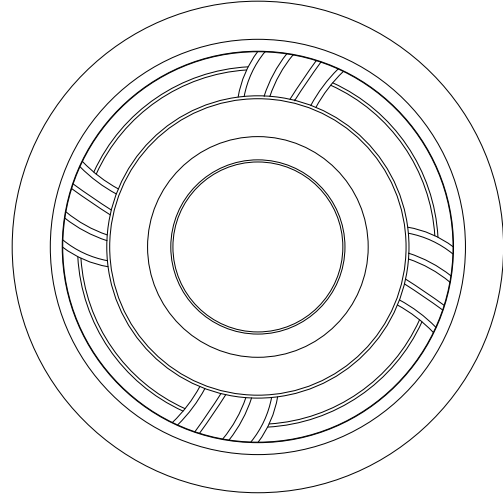
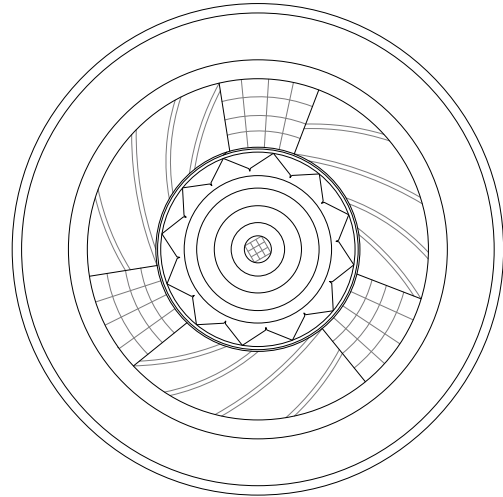
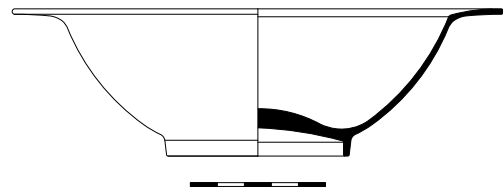

Fig. 3

No. 76

Inv. No. MO1238 | Aron 277

*Exterior**Interior**Profile*

No. 76

Inv. No. MO1238 | Aron 277

Bowl with ring-shaped base, hemispherical umbo,
curved wall, everted horizontal rim
India, 20th century

Dimensions: diam. 18.2 cm, h. 5.45 cm, weight 354.5 g

Condition: Good.

Content: A divinatory-ritual bowl with Koranic inscriptions and symbolic figurations of the sword of *Dhū'l-faqār*.

Exterior: A continuous inscription on the outer surface of the rim is followed by the *Āyat al-kursī* (the Throne Verse, Kor. 2:255). Beneath this, a wide band composed of square panels contains large-format epigraphs bearing the motto *Lā fatā illā 'Alī lā ṣayf illā Dhū'l-faqār* ("There is no hero but 'Alī, no sword but *Dhū'l-faqār*"), together with depictions of eight two-bladed swords of *Dhū'l-faqār* (Fig. 1). A continuous Koranic inscription surrounds the ring of the base. Four monograms with invocations appear on the outer surface of the umbo.

Interior: On the surface of the rim is the Surah *Yā Sīn* which continues on the upper part of the wall in a continuous inscription (Kor. 36). In the centre of the wall is a series of three square panels containing inscriptions on five diagonal lines, and four squares with 16 boxes containing numbers. 12 niche panels cartouches with magical numerical inscriptions are arranged around the base. Invocations around the umbo.

Comment: This late example of the type of Indo-Persian workmanship, in style and with elements of the Shi'ite world, is characterised by the schematic reproduction of the sword of *Dhū'l-faqār* and magical inscriptions (see nos. 74 and 75).

References:

Unpublished.



Fig. 1

No. 77

Inv. No. MO1236 | Aron 244



Exterior

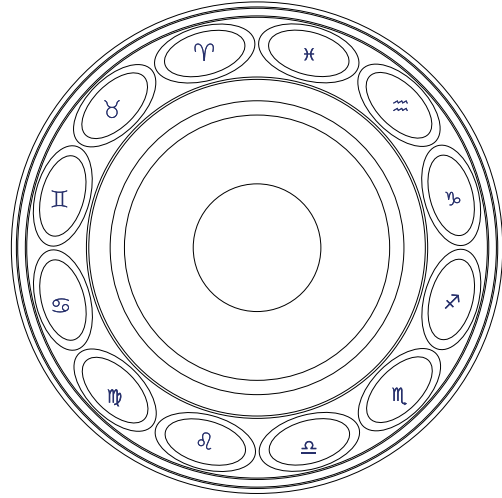

Interior

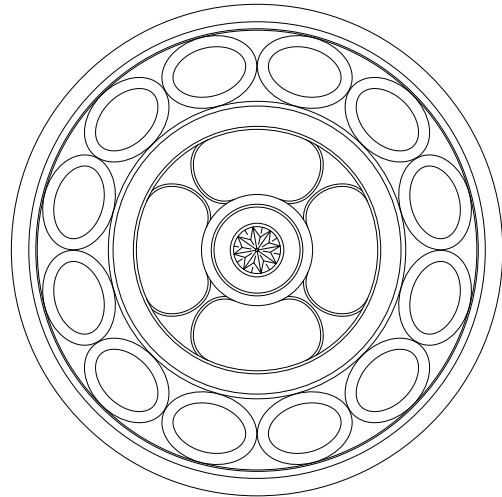

Profile

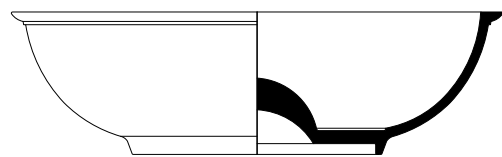

No. 77

Inv. No. MO1236 | Aron 244

Bowl with ring base, hemispherical umbo,
curved wall, everted horizontal rim
Mesopotamia, 1225/1810-11

Dimensions: diam. 20.5 cm, h. 5.94 cm, weight 901 g

Condition: Good.

Content: A divinatory-ritual bowl with a rich repertoire of Koranic inscriptions and Shi'ī invocations. *Yā Shāfi yā Kāfi* type.

Exterior: On the upper part of the wall there is a continuous inscription, containing the *Chahārdah ma'sūm* ("The Fourteen Infallibles"). The central part of the wall is decorated with the 12 zodiacal signs (Fig. 1), next to each of which appears a Koranic inscription divided word by word. Around the ring of the base runs a Koranic inscription. On the base appears a deed to the *waqf* and the name of the owners with the date: "Sons of Nahūr-i Mashhadī Muḥammad Raḥīm Walīd Karbalā'ī. 1225" (1810-11; Fig. 2).

Interior: On the rim surface a magic numeric inscription. In the upper part of the wall, a continuous inscription with the *Āyat al-kursī* (the Throne Verse, Kor. 2:255) that continues below within 12 roundels together with other Koranic verses. Around the base a Koranic continuous inscription. Four cartouches around the umbo contain the invocations: "O Clear! O Sufficient!" (*yā Shāfi yā Kāfi*); "O Sincere! O Exempted!" (*yā Wāfi yā Mu'āfi*); "O Well Done! O Richest!" (*yā Hāyī! yā Aghnā*); "O Judge! O Satisfied!" (*yā Qādī! yā Rādī*). The umbo is decorated with two lines containing a magical numerical inscription, and a star motif at the top (Fig. 3).

Comment: This bowl constitutes a later example within a group defined by epigraphic, decorative, and formal features. A characteristic element is the four-sided arrangement of cartouches around the umbo, each containing similar inscriptions. The recurrence of the formula *yā Kāfi yā Shāfi* further attests to the existence of a homogeneous group of bowls (see nos. 69–70, 78, 83).

References: Unpublished.



Fig. 1



Fig. 2



Fig. 3

No. 78

Inv. No. MO11184 | Aron 302

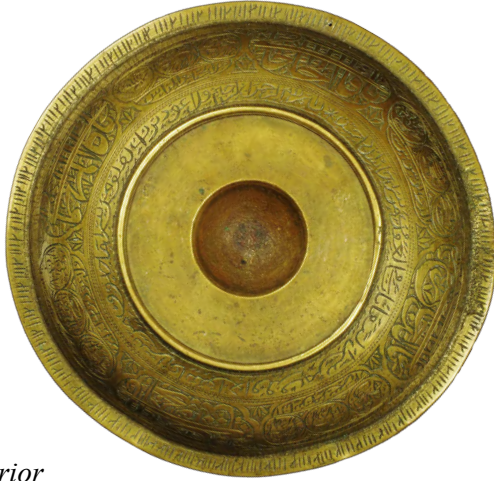

Exterior

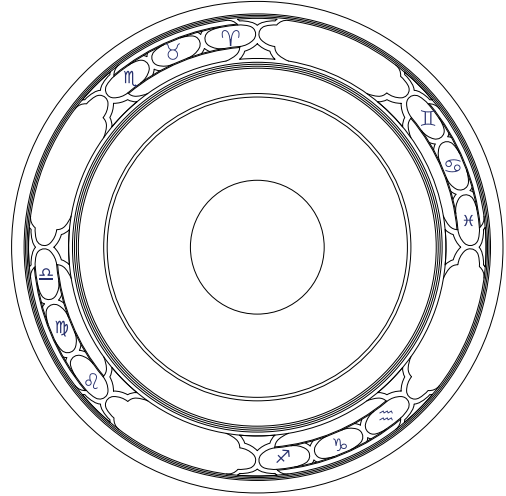

Interior

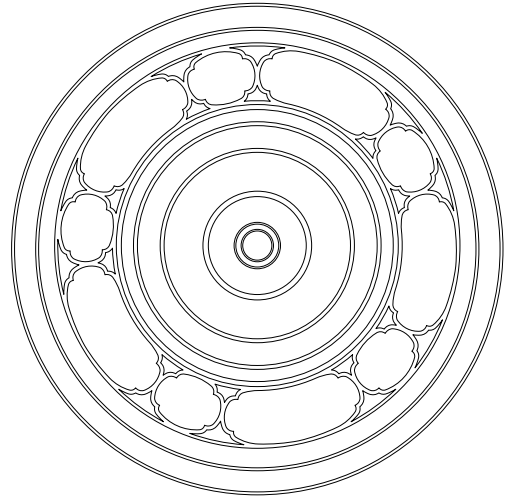

Profile

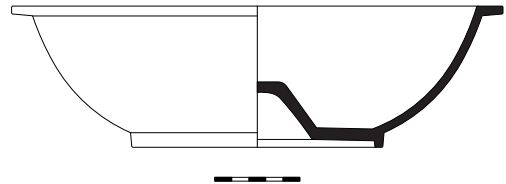

No. 78

Inv. No. MO1184 | Aron 302

Bowl with ring base, hemispherical umbo with flat top;
curved wall, horizontal and everted rim
Mesopotamia or Syria, 19th century

Dimensions: diam. 15.35 cm , h. 5.65 cm; weight 343.8 g

Condition: Good.

Content: A divinatory-ritual bowl with a rich repertoire of Koranic inscriptions and Shi'i invocations. *Yā Kāfī yā Shāfī* type variant.

Exterior: On the outer surface of the rim is a numerical magical inscription, with an inverted Koranic inscription just below. At the centre are eight oval cartouches, divided into two groups: the first contains a single large text featuring invocations such as *yā Kāfī yā Shāfī*, while the second consists of three bands—the upper and lower bands bear Koranic inscriptions, and the middle band displays the signs of the zodiac (Fig. 1). The base is encircled by a continuous Koranic text.



Fig. 1

Interior: A continuous Koranic text runs along the outer surface of the rim. Below, it is another continuous inscription featuring the *Āyat al-kursī* (the Throne Verse, Kor. 2:255), followed by the *sab'a khawātim* ("the Seven Seals"). The central section is decorated with 10 medallions—five oval and five circular—containing Koranic texts outlined in a larger format, along with magical numerical scripts. The oval medallions feature Koranic verses, while the circular ones bear invocations to the angels Jibrā'īl, Mikā'īl (Fig. 2), Azrā'īl, Isrāfīl, and Dardanīl. Two parallel bands with Koranic inscriptions run below the medallions, and around the umbo appears the *Chahārdah ma'sūm*. The umbo itself holds a quadripartite cartouche with additional Koranic texts..

Comment: This bowl of great complexity features a wide repertoire of texts. The inverted Koranic inscription indicates its specific function (see nos. 69–70, 77, 83).

References: Unpublished.



Fig. 2

No. 79

Inv. No. MO1234 | Aron 99

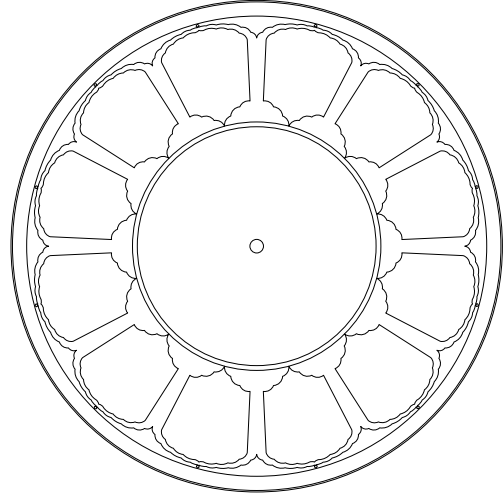
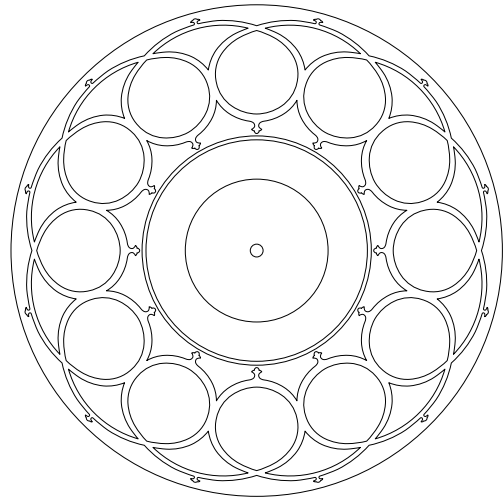
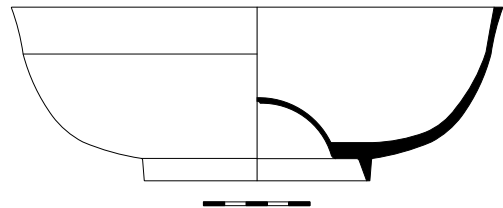
*Exterior**Interior**Profile*

No. 79

Inv. No. MO1234 | Aron 99

Bowl with ring base, hemispherical umbo;
curved wall, straight edge, flat rim
Iran, 1055/1645-46

Dimensions: diam. 22.07 cm, h. 8.15 cm, weight 706.5 g

Condition: Good.

Content: A divinatory-ritual bowl with a rich repertoire of Koranic and Shi'i inscriptions. *Yā Sīn* type.

Exterior: Below the rim is a continuous profiled inscription featuring the *Chahārdah ma'sūm* ("The Fourteen Infallibles") with their attributes, followed by the date of the bowl (1055/1645-46; Fig. 1). The decoration is characterised by 12 "arches" containing the entire Surah *Yā Sīn* (Kor. 36), which continues into the interstitial spaces. Around the base is a magical numeric inscription.



Fig. 1

Interior: Below the rim, a continuous ribbon decoration forms teardrop-shaped cartouches containing the continuation of the exterior Koranic text, along with additional Koranic verses woven into the interstitial spaces (Fig. 2). The umbo features a Koranic inscription arranged in seven parallel lines.

Comment: This finely crafted bowl is distinguished by the complete reproduction of the Surah *Yā Sīn*, a feature also found in other Iranian bowls from the Safavid period.

References: Bernardini in press.



Fig. 2

No. 80

Inv. No. MO1210 | Aron 176



Exterior

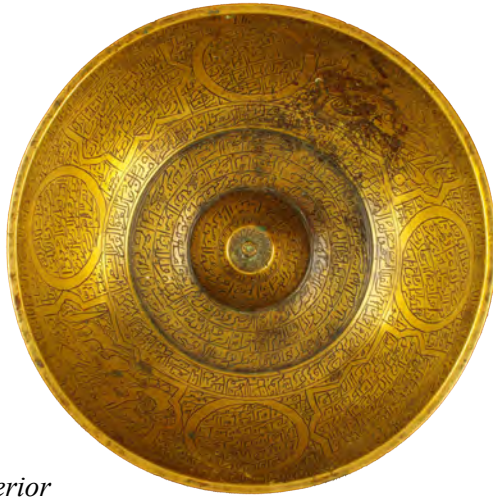
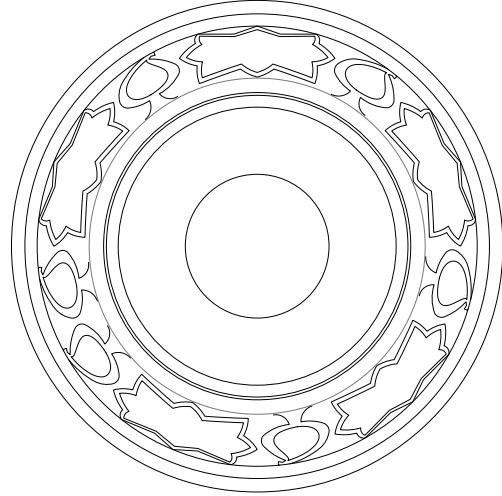

Interior



Profile

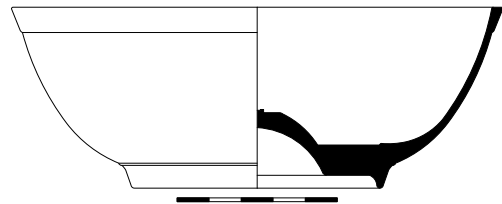

No. 80

Inv. No. MO1210 | Aron 176

Bowl with ring base, hemispherical umbo;
curved wall, straight edge, flat rim
India, 19th century

Dimensions: diam. 15.35 cm, h. 5.65 cm, weight 343.8 g

Condition: Good.

Content: A divinatory-ritual bowl with the whole Surah *Yā Sīn*, Shi‘i invocations and a “Table of Contents”.

Exterior: Below the rim, there is a continuous magical numeric inscription. The central area of the outer surface features a large decorative grid containing both star-shaped and cypress-shaped cartouches (Fig. 1). The entire surface of the bowl is inscribed with the Surah *Yā Sīn* (Kor. 36), along with other Surahs. Invocations dedicated to the Shi‘a family appear inside the cartouches, written in a large script. On the outer surface of the base, a table lists the contents of the bowl (Fig. 2).



Fig. 1

Interior: A continuous inscription runs along the top, with the Surah *Yā Sīn* continuing across the rest of the bowl. Below, star-shaped panels alternate with circular medallions, containing further verses from the same Surah, along with various invocations. The text concludes, accompanied by additional Surahs, on the surface of the base and the umbo.

Comment: This Indian-made bowl is distinguished by the use of original decorative motifs, such as star-shaped panels and cypress-shaped cartouches. While the extensive use of Surah *Yā Sīn* is a common feature, in this case it departs from the traditional epigraphic canon of divinatory-ritual bowls, offering a different treatment of the theme of “The Fourteen Infallibles” and the Koranic Surahs most frequently employed in such objects. The inclusion of a table of contents is another distinctive feature, although it is also found on other similar bowls.

References: Unpublished.

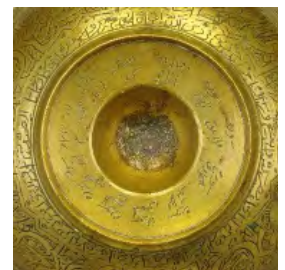
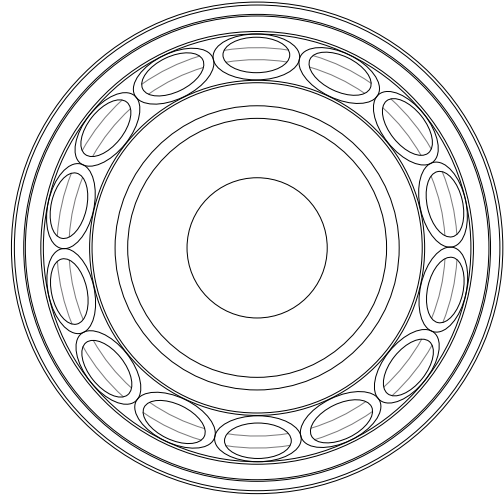
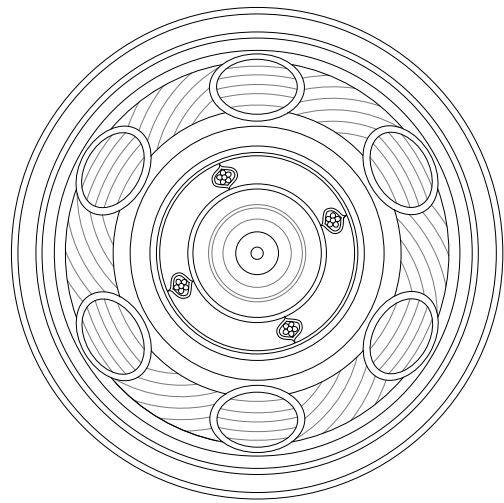
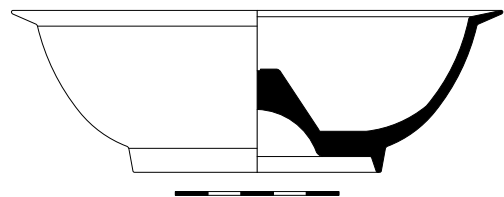

Fig. 2

No. 81

Inv. No. MO1198 | Aron 227

*Exterior**Interior**Profile*

No. 81

Inv. No. MO1198 | Aron 227

Bowl with ring base, hemispherical umbo with flat top,
curved wall, horizontal and everted rim
India, 18th century

Dimensions: diam. 15.03 cm, h. 4.95 cm, weight 370.9 g

Condition: Fair; traces of oxidation and abrasion.

Content: A divinatory-ritual bowl with the whole Surah *Yā Sīn*, Shi'ī invocations and a "Table of Contents".

Exterior: On the outer surface of the rim is a continuous magical numeric inscription. Below the rim, a continuous epigraphic band contains the Surah *Yā Sīn* (Kor. 36). Beneath this is another continuous



Fig. 1

inscription invoking the *Chahārdah ma 'šūm* ("The Fourteen Infallibles"). On the central part of the wall, 16 circular medallions bear Koranic inscriptions (Fig. 1). Around the base and on the foot ring are two continuous Koranic inscriptions with talismanic content. On the outer surface of the base is a table listing the bowl's contents (Fig. 2).

Interior: A continuous Koranic inscription runs along the rim surface. Below the rim, another continuous Koranic inscription is present. The central band features an inscription composed of six circular cartouches containing Koranic verses, interspersed with six additional cartouches bearing texts arranged diagonally over five to six lines. Below this band, a continuous Koranic text encircles the base. Surrounding the umbo, four cartouches contain the *Nādī 'Aliyyan* ("Call upon 'Alī"). On the umbo itself, six horizontally overlapping inscriptions feature additional Koranic verses.



Fig. 2

Comment: This Indian-made bowl is characterised by the use of Surah *Yā Sīn*, a feature commonly found in both Indian and Iranian traditions.

References: Unpublished.

No. 82

Inv. No. MO1240 | Aron 225



Exterior

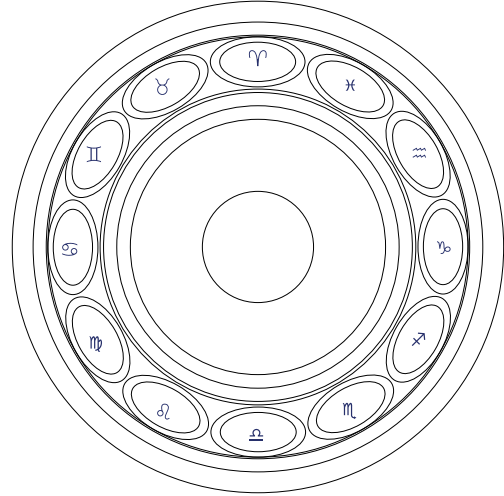

Interior

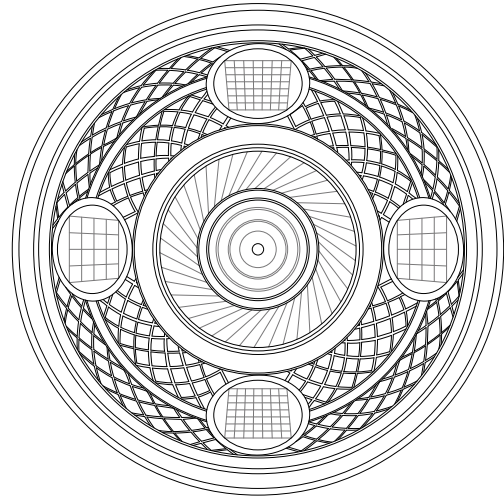

Profile

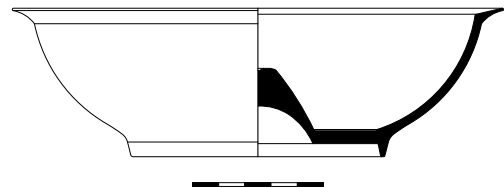

No. 82

Inv. No. MO1240 | Aron 225

Bowl with ring base, hemispherical umbo;
curved wall, horizontally everted rim
Iran, 17th century

Dimensions: diam. 15.03 cm; h 4.95 cm, weight 370.9 g

Condition: Good.

Content: A divinatory-ritual bowl with a rich repertoire of Koranic and Shi'i inscriptions and a "Table of Contents". *Yā Sīn* type.

Exterior: On the rim surface is a magical numeric inscription. Below the rim, a Koranic inscription is distributed across five cartouches. Further down, on the central wall, the 12 signs of the zodiac appear within circular medallions (Fig. 1). Around the base, a Koranic inscription is set within four cartouches. On the base surface is a table listing the bowl's contents (Fig. 2).

Interior: On the outer surface of the rim, the *Āyat al-kursī* (the Throne Verse, Kor. 2:255-257). The epigraphic layout of the interior is almost entirely for the Surah *Yā Sīn* (Kor. 36). The text begins immediately below the rim within two overlapping bands separated by large circular medallions containing number grids, each with 16 squares (Fig. 3). The two bands are separated horizontally by a continuous inscription, and on the inside they form a pattern consisting of a grid of 138 rhombuses containing one or two words each. The Surah *Yā Sīn* continues on the surface of the base in a halo of 14 scrolls arranged in a ragged pattern. Around the umbo appears the *Nādi 'Aliyyan* ("Call upon 'Alī"). The umbo has five cartouches superimposed on horizontal parallel rows.

Comment: This bowl, of high quality of execution, has as its main feature the complete reproduction of the Surah *Yā Sīn*, an element that also appears in other Iranian bowls of the Safavid period.

References: Bernardini in press.



Fig. 1

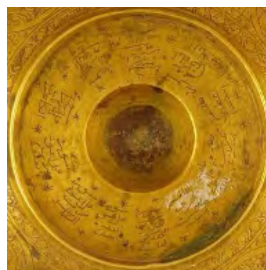

Fig. 2



Fig. 3

No. 83

Inv. No. MO1200 | Aron 226



Exterior

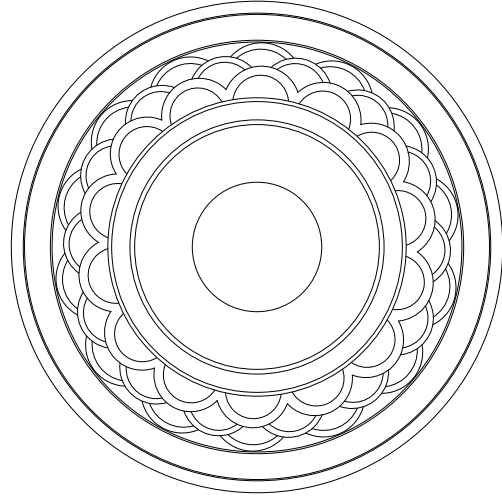

Interior

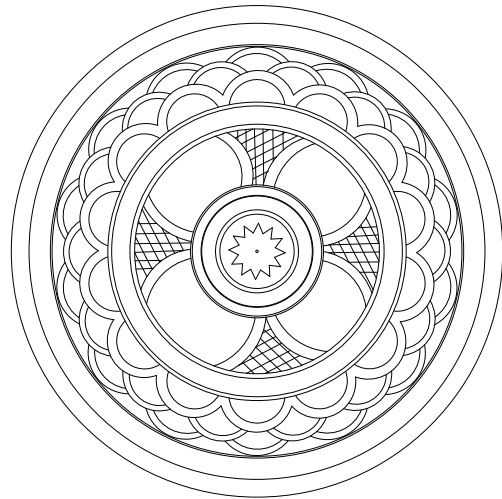

Profile

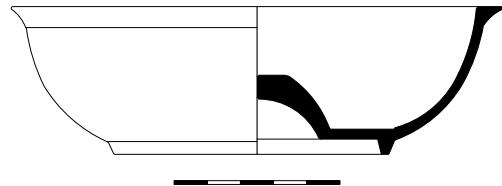

No. 83

Inv. No. MO1200 | Aron 226

Bowl with ring base, hemispherical umbo with flat top,
curved wall, horizontal and everted rim
Syria or Mesopotamia, 18th century

Dimensions: diam. 14.84 cm, h. 4.46 cm, weight 371.4 g

Condition: Fair; losses of inscription due to surface wear and the presence of several small holes.

Content: A divinatory-ritual bowl with a rich repertoire of Koranic verses, Shi'i inscriptions, and invocations. *Yā Kāfi, yā Shāfi* type.

Exterior: Below the rim is the *Chahārdah ma 'šūm* ("The Infallible Fourteen"), divided into four cartouches connected by a bow knot, a characteristic feature of all such bowls (Fig. 1). The *Chahārdah ma 'šūm* continues on the wall in 37 clove-shaped cartouches. Around the base is a magical numeric inscription.

Interior: A magical numeric inscription runs along the surface of the rim. Below the rim is a continuous Koranic inscription. The same exterior pattern is repeated on the wall with 41 clove-shaped cartouches containing Koranic verses (Fig. 2). Around the base is another continuous Koranic inscription. Four cartouches surrounding the umbo bear invocations such as *yā Kāfi, yā Shāfi*. On the umbo itself are two magical numeric inscriptions arranged in parallel lines. A star design surmounts the truncated umbo.

Comment: This bowl belongs to a group united by epigraphic and decorative features, as well as by its form. A characteristic element is a four-sided pattern of four cartouches arranged around the umbo,

each containing similar inscriptions. The recurring formula *yā Kāfi, yā Shāfi* indicates the existence of a well-known, homogeneous group of bowls.

References: Unpublished.



Fig. 1



Fig. 2

No. 84

Inv. No. MO1199 | Aron 331



Exterior

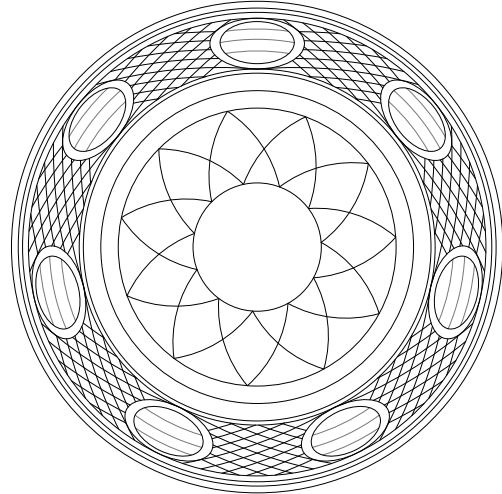

Interior

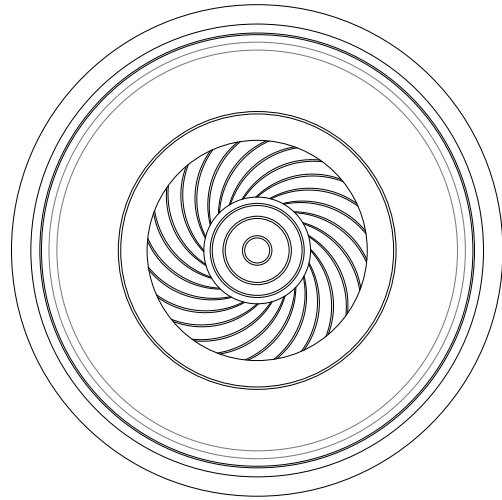

Profile

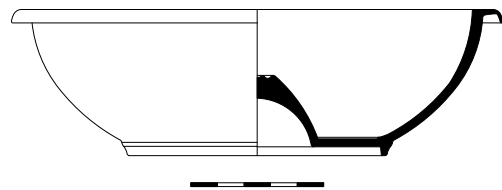

No. 84

Inv. No. MO1199 | Aron 331

Bowl with ring base, hemispherical umbo with flat top;
curved wall, horizontal and everted rim
Iran, 17th century

Dimensions: diam. 18.5 cm, h. 5.5 cm, weight 473 g

Condition: Bad; damaged, showing traces of wear and material loss.

Content: A divinatory-ritual bowl with a rich repertoire of Koranic and Shi'i inscriptions and a "Table of Contents". *Yā Sīn* type.

Exterior: Below the rim is a continuous *Nādī 'Aliyyan* inscription ("Call upon 'Alī"). In the central part of the wall are seven circular medallions containing Koranic inscriptions arranged in four lines, with seven spaces between the medallions divided into oblique squares of 35 compartments each (Fig. 1). Within these squares are repeated groups of invocations bearing the "Beautiful Names" of God. Around the base runs a continuous Koranic text. On the surface of the base is a table of the bowl's contents, set within a star design (Fig. 2).



Fig. 1

Interior: On the outer surface of the rim is the *Āyat al-Kursī* (the Throne Verse, Kor. 2:255–257). The epigraphic layout of the interior consists almost entirely of various Koranic Surahs, particularly the Surah *Yā Sīn* (Kor. 36). The text is arranged in the interstitial spaces between six large circular medallions, each containing alphanumeric squares with 48 cells. Some of these spaces contain the *Chahārdah ma 'šūm* ("The Fourteen Infallibles") and the "Beautiful Names" of God. A continuous Koranic inscription surrounds the base. A swirling inscription decorates the surface of the base within 24 parallel diagonal bands. The umbo features three continuous parallel inscriptions.

Comment: This heavily damaged bowl is primarily distinguished by the inscription of the Surah *Yā Sīn*, a feature also found on other Iranian bowls from the Safavid period.

References: Bernardini in press.



Fig. 2

No. 85

Inv. No. MO1227 | Aron 166



Exterior

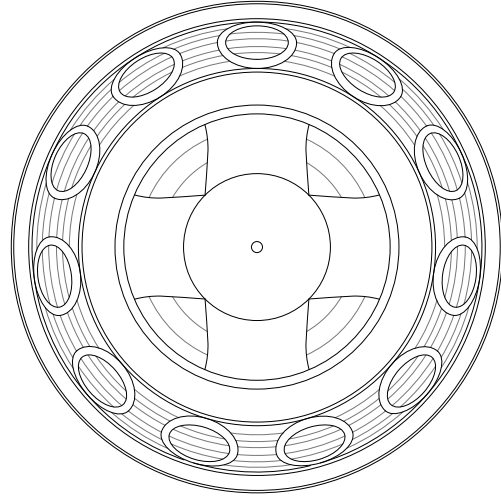

Interior

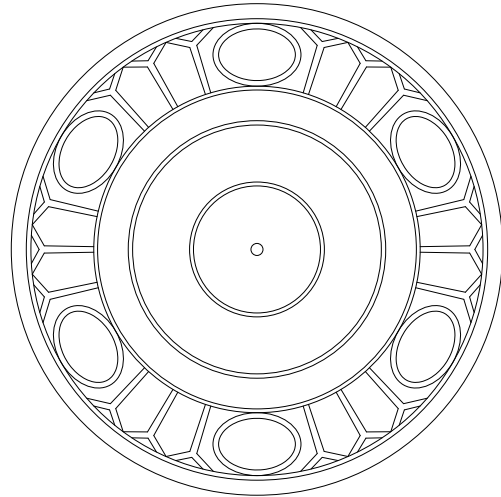

Profile

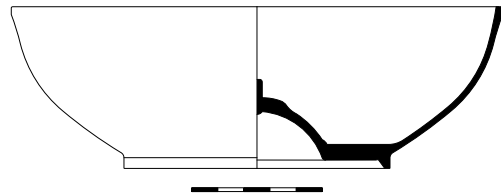

No. 85

Inv. No. MO1227 | Aron 166

Bowl with ring base, hemispherical umbo;
curved wall, straight edge, flat rim
India, 20th century

Dimensions: diam. 18.85 cm; h. 6.2 cm, weight 625 g

Condition: Good; traces of wear.

Content: A divinatory-ritual bowl with the whole Surah *Yā Sīn*, and Shi'ī invocations.

Exterior: Below the umbo is a continuous inscription featuring the *Āyat al-Kursī* (Throne Verse, Kor. 2:255). The same text continues in an inscription around the ring of the base. In the central part of the bowl are 12 circular cartouches containing various Koranic verses and invocations (Fig. 1). Numerical series are arranged on several lines in the interstitial spaces.



Fig. 1

On the base are four triangular, mountain-shaped motifs with numerical inscriptions arranged in parallel lines (Fig. 2).

Interior: Below the rim, a continuous inscription begins with the opening of Surah *Yā Sīn* (Kor. 36), which continues throughout the rest of the bowl's interior. On the wall are 20 pentagonal architectural cartouches, some containing circular medallions with invocations in the form of monograms, as well as two continuous circular inscriptions located in the lower part and around the umbo. The umbo itself is unreadable.

Comment: This Indian-made bowl is characterised by the use of Surah *Yā Sīn*, a feature commonly found in both Indian and Iranian contexts.



Fig. 2

References: Unpublished.

No. 86

Inv. No. MO1243 | Aron 401



Exterior

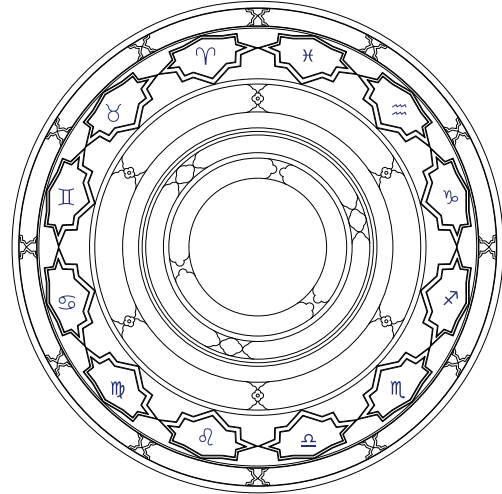

Interior

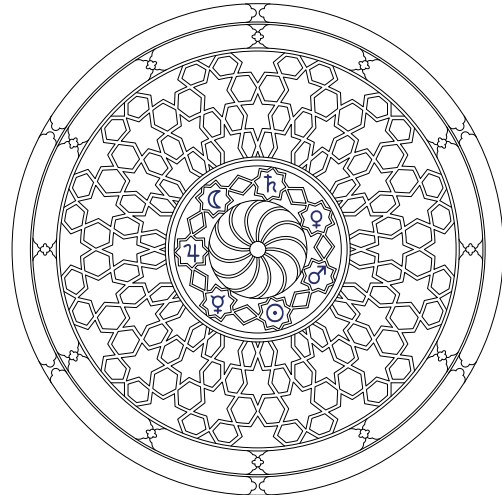

Profile

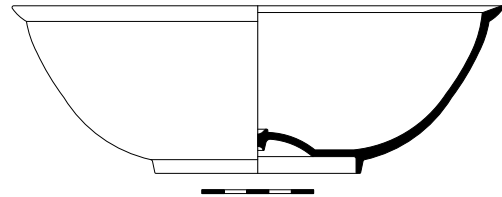

No. 86

Inv. No. MO1243 | Aron 401

Bowl with ring base, hemispherical umbo;
curved wall, slightly everted rim
Iran, 1020/1611

Dimensions: diam. 22 cm, h 7.5 cm, weight 930 g

Condition: Good.

Content: A divinatory-ritual bowl featuring the entire Surah *Yā Sīn*, Shi'ī invocations, and a “Table of Contents”.

Exterior: On the outer surface of the rim, a continuous inscription features Surah *Yā Sīn* (Kor. 36). Below the rim, 12 cartouches contain the *Chahārdah ma 'šūm* (“The Fourteen Infallibles”). The central part of the wall is decorated with 12 star-shaped medallions enclosing the signs of the zodiac (Fig. 1). The spaces between them continue with the Surah *Yā Sīn*. An epigraphic band, divided into three cartouches, bears the *Nādi 'Aliyyan* (“Call upon 'Alī”). Around the base appears the name of the owner, Muḥammad Taqī Ibn Qanbar 'Alī Beyg, alongside the date of the beginning and completion: *Ramaḍān-Rabī' al-Awwal*, year 1020 (May 1611).



Fig. 1

Interior: On the rim, within six lobed cartouches, is the *Āyat al-Kursī* (the Throne Verse, Kor. 2:255-258). Below the rim, within 12 cartouches, appears the *Du 'ā' ajrahu 'azīm 'an al-nabī (Du 'ā' al-qadh)*, known as the “Prayer Supreme Reward of the Prophet” (the Prayer of the Bowl). The wall is adorned with 145 cartouches arranged in an interwoven pattern of rhombuses and six-pointed stars, containing the continuation of Surah *Yā Sīn* (Fig. 2). The surface around the umbo features 21 cartouches formed by an interlacing of star-shaped figures and square panels. Every third cartouche depicts a planetary figure (Saturn, Venus, Mars, Sun, Mercury, Jupiter, Moon). The continuation of Surah *Yā Sīn* completes the inscription on the umbo.



Fig. 2

Comment: The extensive use of the Surah *Yā Sīn* is a common feature in many bowls from the Safavid period.

References: Bernardini in press.

No. 87

Inv. No. MO1247 | Aron 265



Exterior

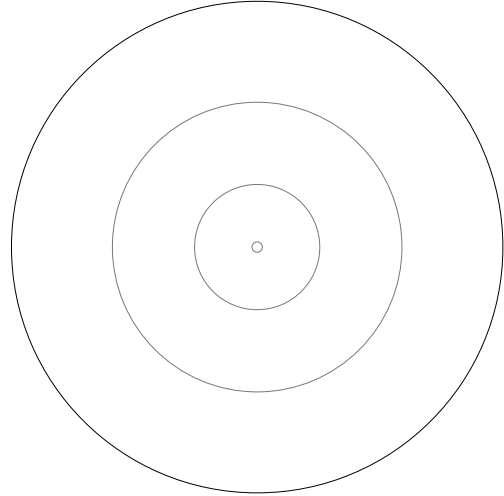

Interior

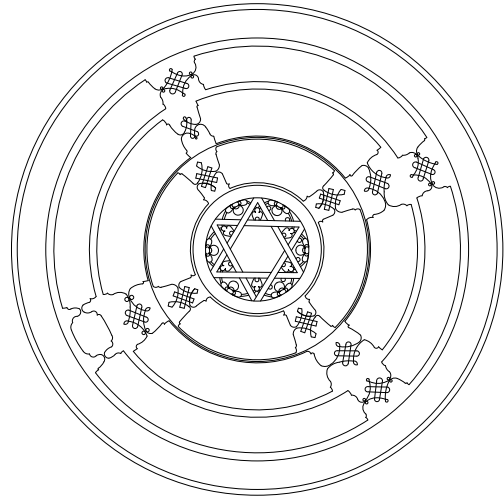

Profile

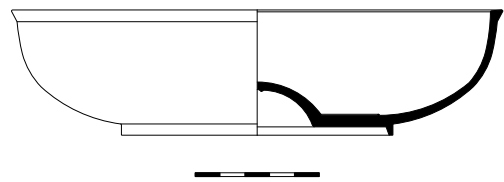

No. 87

Inv. No. MO1247 | Aron 265

**Bowl with ring-shaped base, hemispherical umbo,
curved wall, slightly everted horizontally edge
Anatolia, 1161/1748**

Dimensions: . diam. 19.82 cm, h. 5.05 cm, weight 657 g

Condition: Good; some traces of metal erosion.

Content: A divinatory-ritual bowl.

Exterior: Devoid of decoration.

Interior: Four concentric epigraphic bands adorn the interior, featuring elegant cursive script with typically Sunni content. Following the *Āyat al-Kursī* (the Throne Verse) is a curse against Satan, the names of the four Rashīdūn caliphs, and at the centre of the umbo surface, a Seal of Solomon (Fig. 1). In a cartouche—apparently retouched—appears the owner's name, 'Atiya Khātūn, along with the date 1161/1748 (Fig. 2).

Comment: This Ottoman bowl appears to have been crafted for a high-ranking patron. It fully embodies the Ottoman Baroque style of its era, while also showing strong similarities in shape to bowls traditionally used in hammams.

References: Unpublished.



Fig. 1



Fig. 2

No. 88

Inv. No. MO1225 | Aron 452



Exterior

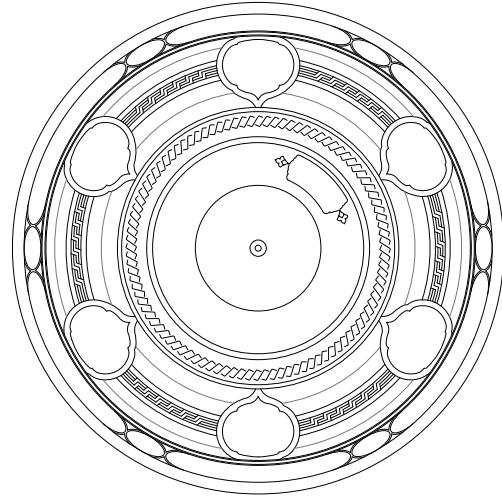

Interior

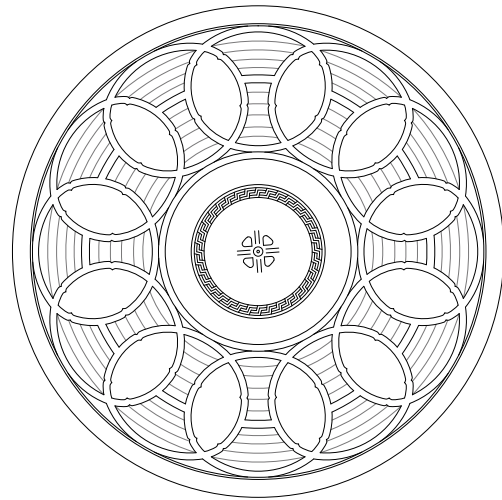

Profile

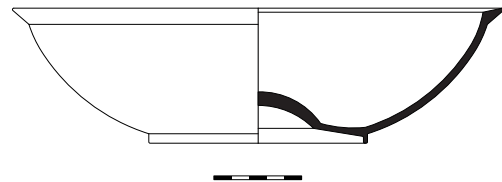

No. 88

Inv. No. MO1225 | Aron 452

Bowl with ring-shaped base, hemispherical umbo,
curved wall, horizontally everted rim
Iran, 15th–16th century

Dimensions: diam. 22.5 cm, h. 6.91 cm, weight 795 g

Condition: Poor; the interior surface is partially worn due to use.

Content: A divinatory-ritual bowl with a rich repertoire of Koranic and Shi'i inscriptions.

Exterior: Below the rim, six cartouches contain the *Chahārdah ma'sūm* ("The Fourteen Infallibles"), alternating with six roundels featuring peony flowers (Fig. 1). The wall of the bowl is decorated with six circular medallions containing Koranic verses, connected by four horizontal incised lines, two of which also bear Koranic texts. On the base, within a cartouche, appears the name of the owner (Fig. 2).

Interior: On the rim surface of the bowl is a continuous Koranic inscription. Inside, a decorative grid formed by a continuous ribbon creates 12 almond-shaped patterns, each containing Koranic verses.

Comment: This specimen, damaged on the inside, belongs to a group of bowls made in Iran between the 15th and 16th centuries. These bowls share common features, notably the prominent use of the *Chahārdah ma'sūm* text.

References: Unpublished.



Fig. 1



Fig. 2

No. 89

Inv. No. MO1230 | Aron 453



Exterior

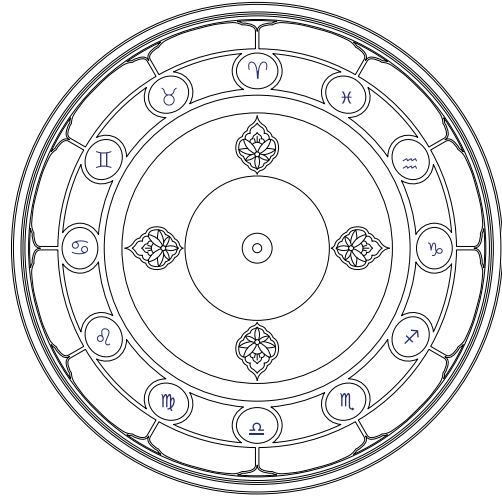

Interior

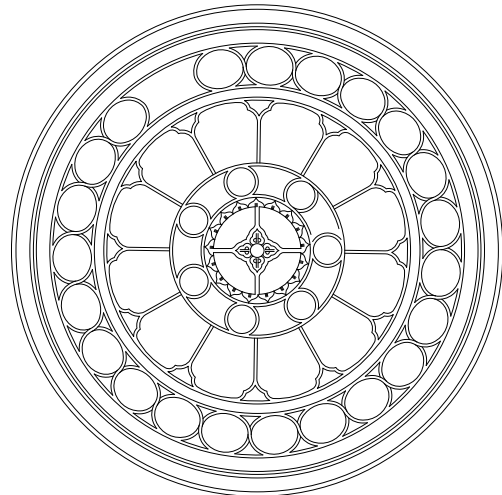

Profile

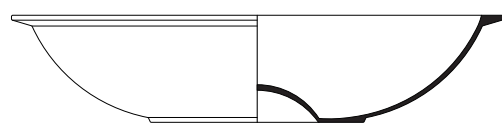

No. 89

Inv. No. MO1230 | Aron 453

**Bowl with ring base, hemispherical umbo,
curved wall, slightly everted rim
Iran, 16th century**

Dimensions: diam. 28.3 cm; h. 6.15 cm

Condition: Good.

Content: A divinatory-ritual bowl with the Koranic inscriptions and Shi'i invocations.

Exterior: On the outer surface of the rim is a continuous Koranic inscription, mirrored by another just below the rim. The upper section of the wall features a Koranic inscription enclosed within 12 arched cartouches. Below these are 12 circular medallions containing the signs of the zodiac. In the interstitial spaces, additional Koranic inscriptions are present. On the base, four invocations alternate with four cartouches decorated with peony-flower motifs.

Interior: On the rim is a continuous Koranic inscription, which continues below the rim within 12 cartouches. On the wall, 22 medallions contain Koranic inscriptions, extending further down into 12 arched cartouches. Around the umbo are depictions of the planets (Fig. 1). The umbo itself contains a quadripartite inscription arranged within triangular panels.

Comment: This bowl is similar to several examples from the Safavid period.

References: Unpublished.



Fig. 1

No. 90

Inv. No. MO1208 | Aron 165

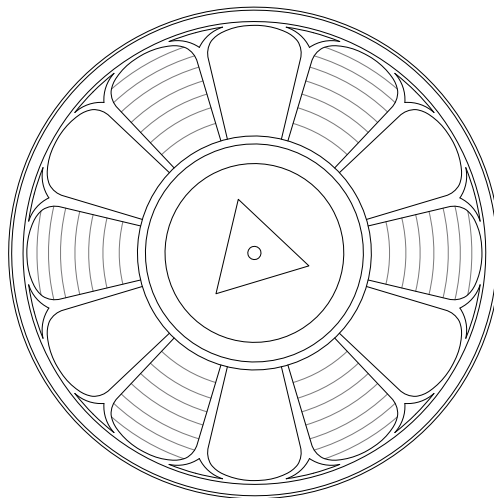
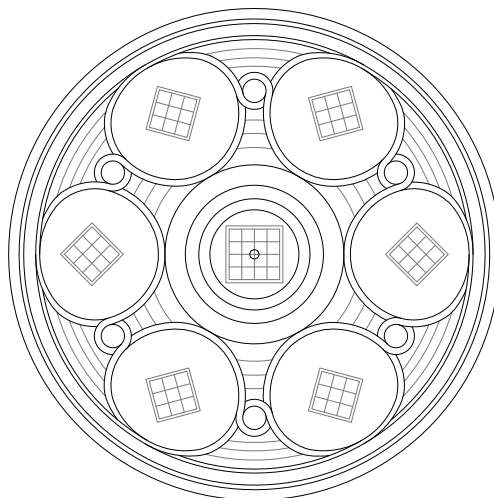
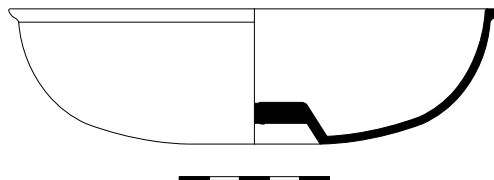
*Exterior**Interior**Profile*

No. 90

Inv. No. MO1208 | Aron 165

Bowl with flat base, truncated umbo,
curved wall, straight edge, flat rim
Anatolia or Mesopotamia, 18th century

Dimensions: diam 16.36 cm; h. 4.5 cm; weight 379.4 g

Condition: Bad; very worn especially on the inside.

Content: A divinatory-ritual bowl with a repertoire of Koranic verses and Shi'i invocations.

Exterior: Below the rim, a continuous inscription features an invocation and passages from the Koran. At the center of the wall, 12 arch-shaped cartouches contain six Koranic inscriptions alternating with six alphanumeric grids (Fig. 1). Around the umbo an unreadable continuous inscription.

Interior: On the rim surface, there is the *Chahārdah ma'sūm* ("The Fourteen Infallibles"). Below the rim a Koranic continuous inscription appears alongside the *Nādi 'Aliyyan* ("Call upon 'Alī"). On the upper wall, cartouches formed by the intersection of a continuous band create smaller and larger circles, but they are difficult to read due to wear (Fig. 2). Around the umbo a continuous Koranic inscription. At the top of the umbo, a square grid spells out the name of Muḥammad, with one letter—M, Ḥ, M, and D—in each box.

Comment: This bowl has characteristics similar in shape to a large group of Anatolian specimens (see nos. 91–100). However, in terms of content, it is more reminiscent of bowls commonly found in Iraq and Iran.

References: Unpublished.

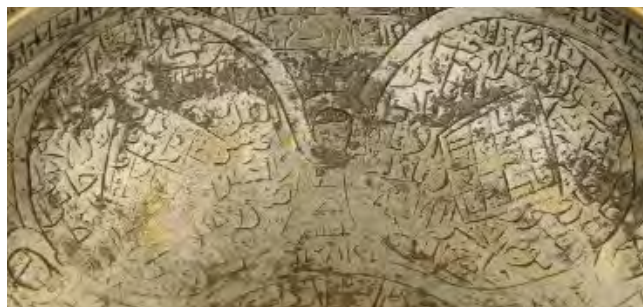

Fig. 1



Fig. 2

No. 91

Inv. No. MO1187 | Aron 275



Exterior

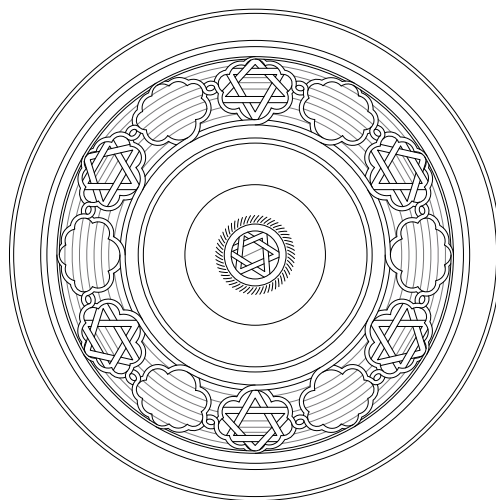

Interior

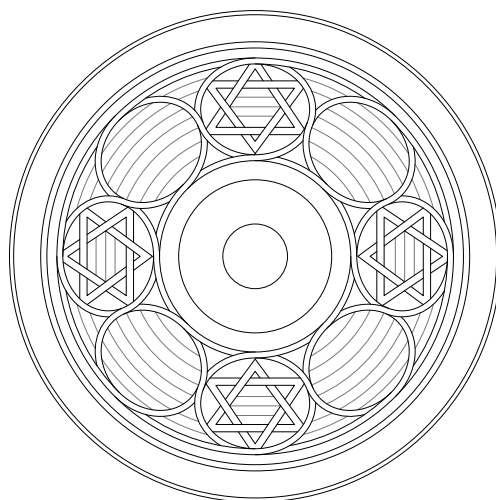

Profile

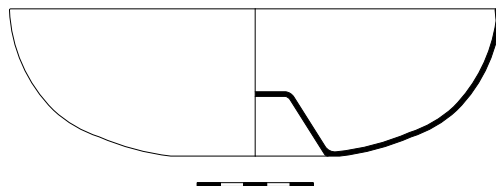

No. 91

Inv. No. MO1187 | Aron 275

**Bowl with flat base, truncated umbo,
curved wall, straight edge, flat rim**
Anatolia, 18th century

Dimensions: diam. 21.2 cm, h. 6.35 cm, 410.3 g

Condition: Bad; signs of wear, especially on the inside.

Content: A divinatory-ritual bowl with a repertoire of Koranic verses and invocations.

Exterior: Below the rim, a continuous inscription features the *Āyat al-Kursī* (Throne Verse, Kor. 2:255–257). Beneath this, a continuous band displays arranged Koranic inscriptions (Fig. 1). In the middle of the wall, 12 polylobed medallions are divided into six bearing Koranic texts, alternating with six others containing magical numeric inscriptions within the “Seal of Solomon” (Fig. 2). Below these, there is a continuous Koranic inscription.



Fig. 1

Interior: Below the rim, a continuous circular inscription contains the continuation of *Āyat al-Kursī*. Beneath it is a continuous Koranic inscription. In the middle of the wall, there are four cartouches with seven lines each, alternating with four “Seal of Solomon” motifs featuring three lines each. The latter part, as well as the umbo and base, are unreadable due to abrasion of the text.

Comment: This bowl, along with several others (nos. 90, 92–100), belongs to a fairly homogeneous group distinguished by predominantly Sunni magical inscriptions and invocations. Many examples are found throughout the Anatolian region, where they enjoyed considerable popularity.

References: Unpublished.



Fig. 2

No. 92

Inv. No. MO1209 | Aron 431

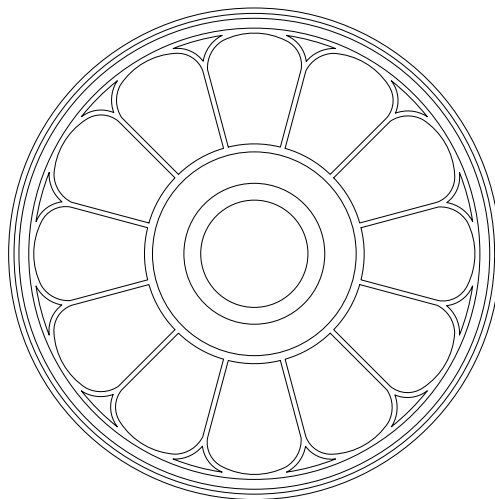
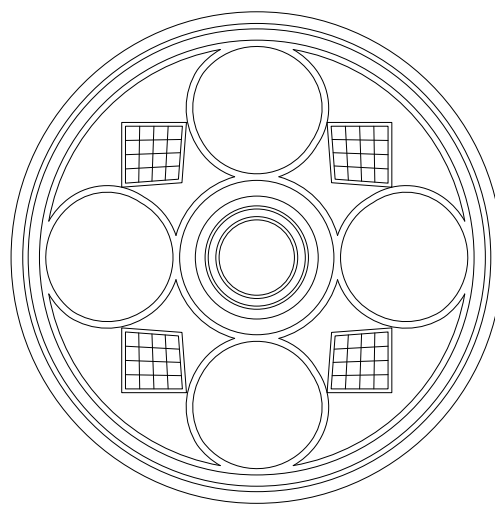
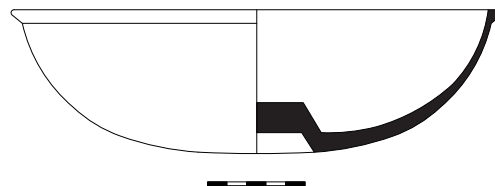
*Exterior**Interior**Profile*

No. 92

Inv. No. MO1209 | Aron 431

Flat base, truncated umbo, curved wall, straight edge, flat rim
Anatolia or Mesopotamia, 18th century

Dimensions: diam. 16.36 cm, h. 4.5 cm, weight 379.4 g

Condition: Bad; very worn especially on the inside.

Content: A divinatory-ritual bowl with a repertoire of Koranic verses and Shi'i invocations.

Exterior: Below the rim, a continuous inscription features an invocation and passages from the Koran. In the middle of the wall, 12 arch-shaped cartouches enclose six Koranic verses. The spaces between them contain the names of the 12 zodiac signs. On the surface of the umbo is the name of the owner.

Interior: On the rim surface, the *Chahārdah ma'sūm* ("The Fourteen Infallibles") are inscribed. Below the rim, a continuous Koranic inscription appears alongside the *Nādi 'Aliyyan* ("Call upon 'Alī"). On the upper part of the wall, cartouches formed by the intersection of a continuous band create smaller and larger circles containing Koranic inscriptions. Around the umbo, there is a continuous Koranic inscription. At the top of the umbo, a square grid contains the word "Budūh" and the name of Muḥammad, with each box holding one of the letters M, Ḥ, M, and D.

Comment: This bowl shares similar characteristics, especially in shape, with a large group of Anatolian specimens (see nos. 90–91, 93–100); however, in terms of content, it is more reminiscent of bowls commonly found in Iraq and Iran.

References: Unpublished.



Fig. 1

No. 93

Inv. No. MO1188 | Aron 86

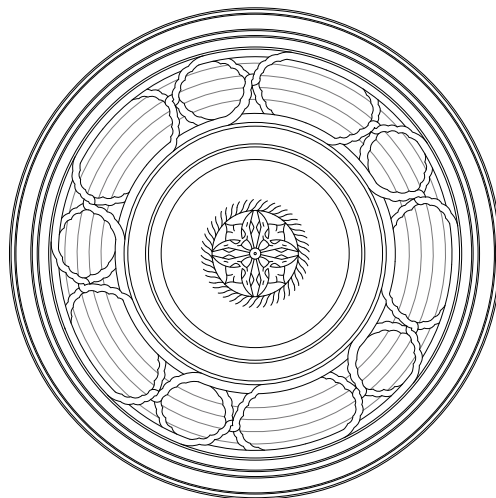
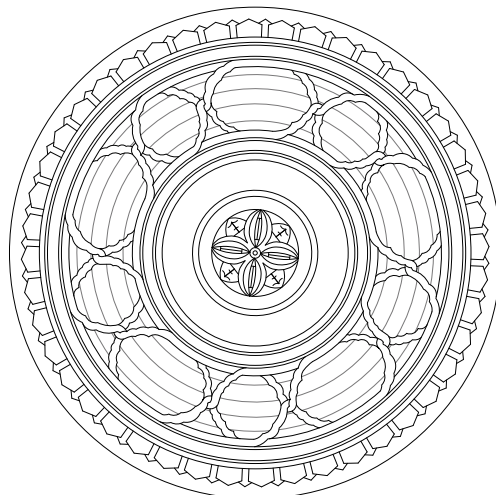
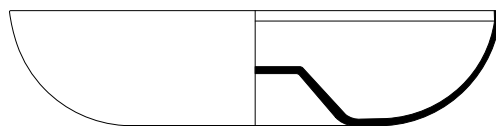
*Exterior**Interior**Profile*

No. 93

Inv. No. MO1188 | Aron 86

Bowl with flat base, truncated umbo;
curved wall, straight edge, flat rim
Anatolia, 18th century

Dimensions: diam. 21.27 cm, h. 4.97 cm, weight 541 g

Condition: Good.

Content: A divinatory-ritual bowl with a repertoire of Koranic verses and invocations. *Yā Kāfī, yā Shāfī* type.

Exterior: Below the rim, a continuous profiled inscription features the *Āyat al-Kursī* (the Throne Verse, Kor. 2:255–257), followed by another continuous inscription with repeated monograms in square script bearing the invocation *yā Kāfī yā Shāfī* (O Sufficient! O Pure!). In the middle of the wall, 10 cartouches—five round and five oval—display repeated the monogram *ya 'Alī* in square script. Below these, a continuous inscription again repeats the monograms *yā Kāfī yā Shāfī* in square script. On the base, within the hollow of the umbo, an invocation is written in profiled letters. At the centre of the umbo, there is a flower.

Interior: Below the rim, there are 44 pentagonal architectural cartouches with the monogram *yā 'Alī* repeated in square script inside each. The same monogram appears below, repeated in a continuous inscription. In the middle of the wall, 10 cartouches—five round and five oval—also display the monogram *yā 'Alī* in square script (Fig. 1). Around the umbo, a continuous inscription repeats the monograms *yā Kāfī yā Shāfī* in square script. On the surface of the umbo, an invocation is written in profiled script. A four-petaled flower stands out on the top of the umbo. (Fig. 2).

Comment: This bowl, along with several others (nos. 90–92, 94–100), belongs to a relatively homogeneous group distinguished by predominantly Sunni magical inscriptions and invocations. Numerous examples have been found throughout the Anatolian region, where they achieved significant popularity.

References: Allan 1986: 42-47.



Fig. 1



Fig. 2

No. 94

Inv. No. MO1182 | Aron 281



Exterior

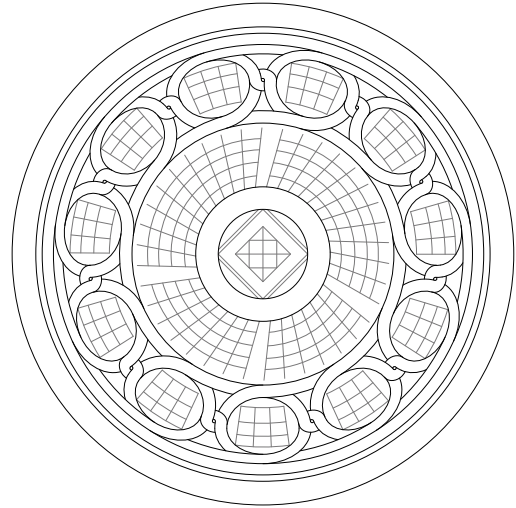

Interior

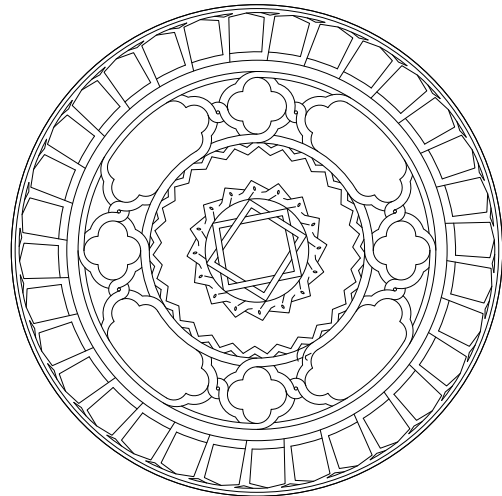

Profile

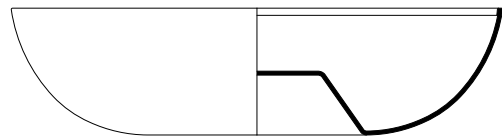

No. 94

Inv. No. MO1182 | Aron 281

Bowl with flat base, truncated umbo;
curved wall, straight edge, flat rim
Anatolia, 18th century

Dimensions: diam. 18.8 cm, h. 4.85 cm, weight 323 g

Condition: Good; slight signs of damages.

Content: A divinatory-ritual bowl with a repertoire of Koranic verses and invocations.

Exterior: Below the rim is a continuous profiled inscription featuring the *Āyat al-Kursī* (Throne Verse, Kor. 2:255-257; Fig. 1), followed by a continuous inscription containing the “Beautiful Names” of God (*Asmā’ al-Ḥusnā*). Around the base are 11 circular medallions enclosing magic squares. In the recess of the umbo are four alphanumeric grids, each with 24 spots. At the centre is a quadripartite square containing isolated letters.

Interior: In the upper band, there are 32 magic squares shaped like pentagonal niches, alternating between 16-square grids and four-row tables. Below this is a continuous Koranic inscription ending with a curse against Satan. Four magic squares within four-lobed medallions are intertwined with four alphanumeric cartouches that alternate Koranic verses and numerical sequences. On the umbo surface is an invocation in profiled script. At the inner top of the umbo is a Seal of Solomon with the word *Allāh* at its centre.

Comment: This bowl, together with several others (nos. 90–93, 95–100), forms a rather homogeneous group characterized mainly by Sunni magical texts and invocations. Many of these are found in the Anatolian region, where they were particularly popular..

References: Unpublished.



Fig. 1

No. 95

Inv. No. MO1181 | Aron 264

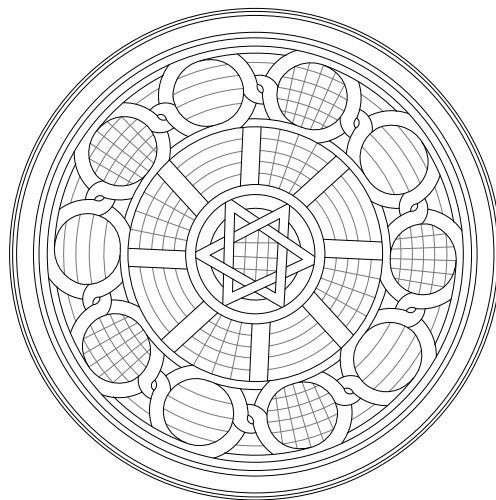
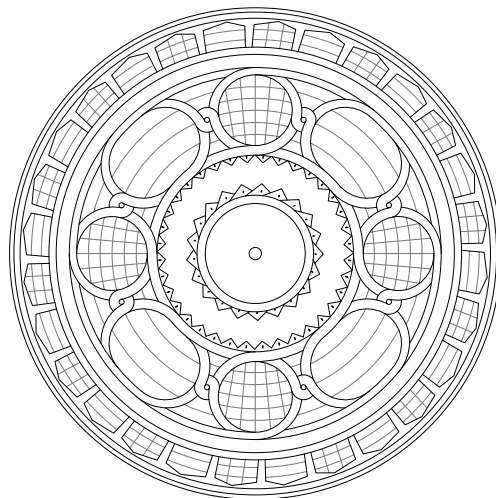
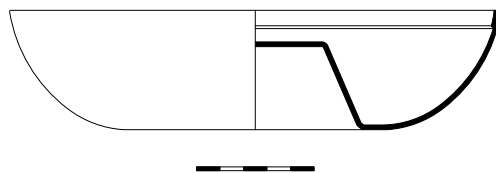
*Exterior**Interior**Profile*

No. 95

Inv. No. MO1181 | Aron 264

Bowl with flat base, truncated umbo;
curved wall, straight edge, flat rim
Anatolia, 19th century

Dimensions: diam. 20.92 cm, h. 5.08 cm, weight 453.4 g

Condition: Good.

Content: A divinatory-ritual bowl with a repertoire of Koranic verses and invocations.

Exterior: Below the rim is a continuous profiled inscription featuring the *Āyat al-Kursī* (Throne Verse, Kor. 2:255-257), followed by a continuous magical numeric inscription. Around the base are 10 circular medallions containing magic squares (Fig. 1). In the hollow of the umbo are eight alphanumeric grids, each with 20 spots. At the centre is a Seal of Solomon surrounded by numerical inscriptions, containing a magic square within.

Interior: In the upper band, there are 26 magic squares shaped like pentagonal niches, alternating between nine-square grids and numerical tables arranged in three lines. Below this runs a continuous inscription featuring the “Beautiful Names” of God. Further down, four magic squares within four-lobed medallions are intertwined with four alphanumeric cartouches that alternate Koranic verses and numerical sequences. On the umbo surface is an invocation in profiled script. At the inner top of the umbo are four invocations (Fig. 2).

Comment: This bowl, together with several others (nos. 90–94, 96–100), forms a rather homogeneous group characterized mainly by Sunni magical texts and invocations. Many of these are found in the Anatolian region, where they were particularly popular.

References: Unpublished.



Fig. 1



Fig. 2

No. 96

Inv. No. MO1180 | Aron 216



Exterior

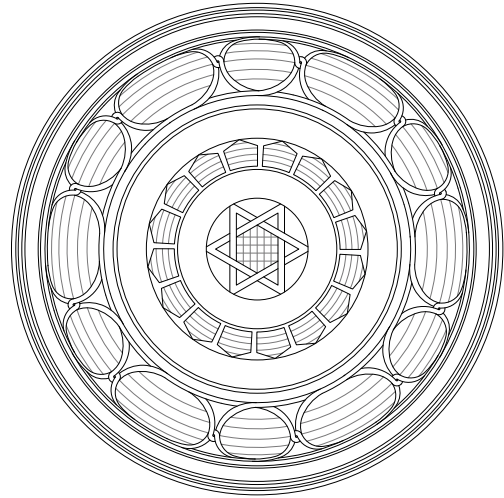

Interior

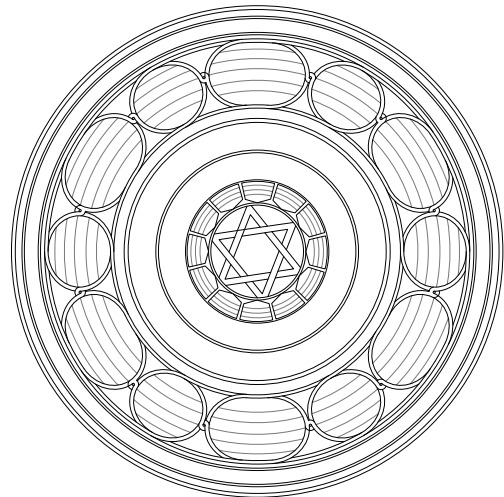

Profile

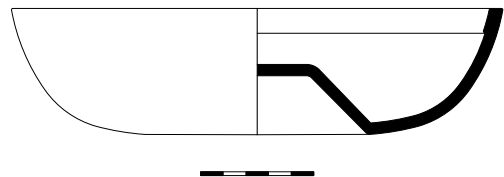

No. 96

Inv. No. MO1180 | Aron 216

Bowl with flat base, truncated umbo,
curved wall, straight edge, flat rim
Anatolia, 18th century

Dimensions: diam. 21.7 cm, h. 5.58 cm, weight 681.5 g

Condition: Good.

Content: A divinatory-ritual bowl with a repertoire of Koranic verses and invocations. *Yā Kāfī, yā Shāfī* type.

Exterior: Beneath the rim runs a continuous profiled inscription of the *Āyat al-Kursī* (Throne Verse, Kor. 2:255-257; Fig. 1), followed by another continuous inscription repeating *yā Kāfī yā Shāfī* (O Sufficient! O Pure!). At the centre of the base are 12 circular and oval medallions inscribed with the same text. The hollow surface of the umbo features 16 pentagonal grids, each with five lines containing repeated monograms of *yā 'Alī*. At the very centre of the umbo lies a Seal of Solomon, encircled by numerical inscriptions and enclosing a magic square.



Fig. 1

Interior: Below the rim runs a continuous profiled inscription of the *Āyat al-Kursī* (Kor. 2:255-257), followed by a continuous inscription repeating *yā Kāfī yā Shāfī*. At the centre of the base, 12 circular and oval medallions bear the same invocation. Encircling the umbo is another continuous inscription of *yā Kāfī yā Shāfī*. The umbo surface features an invocation in profiled script, while its summit is adorned with a Seal of Solomon inscribed with *Allāh Haqq* (Fig. 2).



Fig. 2

Comment: This bowl, together with several others (nos. 90–95, 97–100), forms a rather homogeneous group characterized mainly by Sunni magical texts and invocations. Many of these are found in the Anatolian region, where they were particularly popular.

References: Unpublished.

No. 97

Inv. No. MO1179 | Aron 251



Exterior

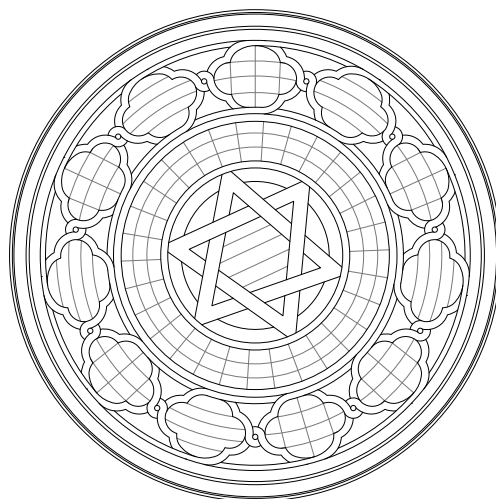

Interior

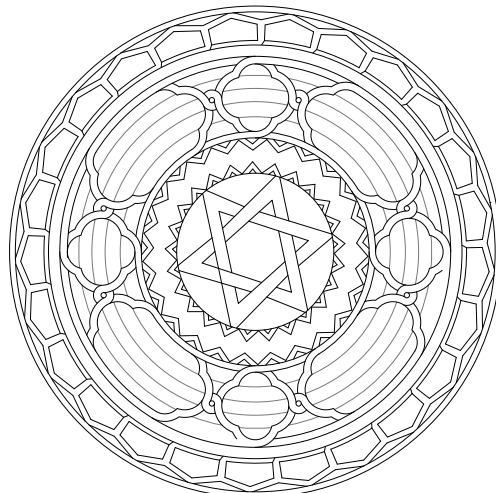

Profile

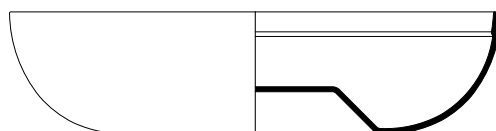

No. 97

Inv. No. MO1179 | Aron 251

Bowl with flat base, truncated umbo, curved wall,
straight edge, flat rim
Anatolia, 19th century

Dimensions: diam. 19.85 cm, h. 4.92 cm, weight 503 g

Condition: Bad; worn and mostly illegible.

Content: A divinatory-ritual bowl with a repertoire of Kornic verses and invocations. *Yā Kāfī*, *yā Shāfī* type.

Exterior: Below the rim is a continuous inscription of the *Āyat al-Kursī* (Throne Verse, Kor. 2:255-257; Fig. 1), followed by another continuous Koranic inscription. In the middle of the wall are 12 polylobed medallions, now illegible. On the hollow surface of the umbo is a grid with 93 boxes containing alphanumeric inscriptions. At the center lies a Seal of Solomon enclosing a magic text (Fig. 2).



Fig. 1

Interior: Below the rim are 25 pentagonal architectural cartouches containing the word *Allāh*, followed by a continuous Koranic inscription. In the middle of the wall are eight cartouches—four round and four oval—that are illegible due to wear.

Comment: This bowl, together with several others (nos. 90–96, 98–100), forms a rather homogeneous group characterized mainly by Sunni magical texts and invocations. Many of these are found in the Anatolian region, where they were particularly popular.

References: Unpublished.



Fig. 2

No. 98

Inv. No. MO1189 | Aron 352



Exterior

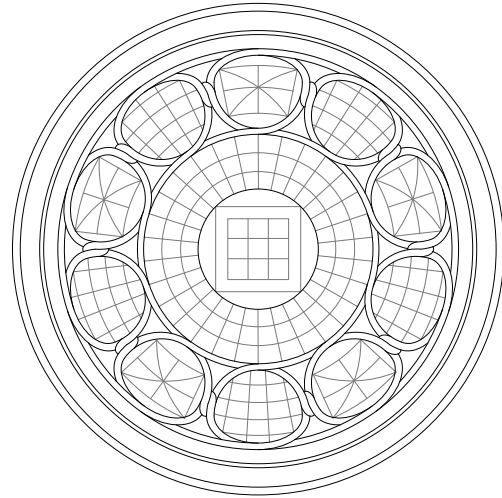

Interior

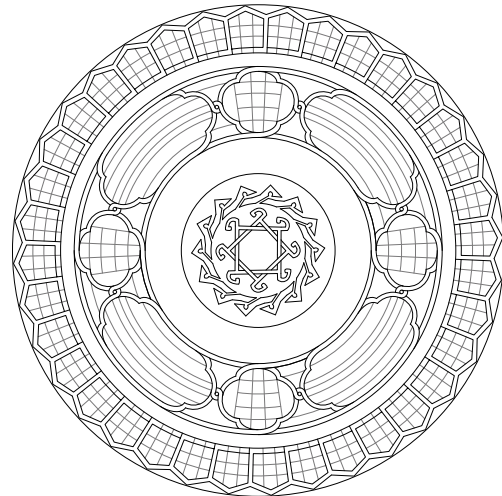

Profile

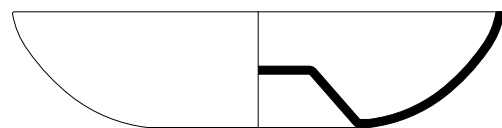

No. 98

Inv. No. MO1189 | Aron 352

Bowl with flat base, truncated umbo,
curved wall, straight edge
Anatolia, 17th century

Dimensions: diam. 15.3 cm, h. 3.6 cm, weight 257 g

Condition: Bad; many parts worn or completely illegible.

Content: A divinatory-ritual bowl with a repertoire of Koranic verses and invocations.

Exterior: Below the rim is a continuous profiled inscription of the *Āyat al-Kursī* (Throne Verse, Kor. 2:255), followed by another continuous Koranic text. In the middle of the wall are 10 cartouches arranged in four lines, containing alphabetical and numerical grids (Fig. 1). The umbo features a magic square.

Interior: Unreadable.

Comment: This bowl, together with several others (nos. 90–97, 99–100), forms a rather homogeneous group characterized mainly by Sunni magical texts and invocations. Many of these are found in the Anatolian region, where they were particularly popular.

References: Unpublished.



Fig. 1

No. 99

Inv. No. MO1186 | Aron 229

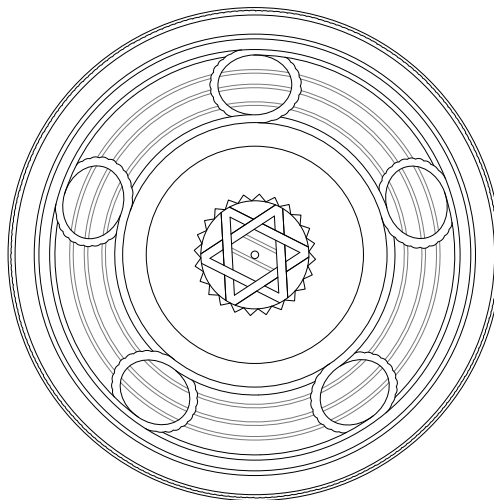
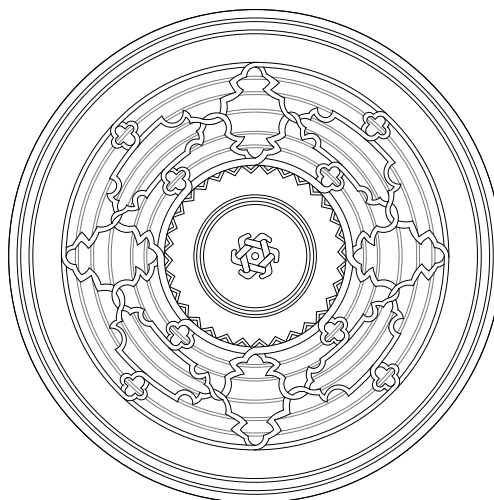
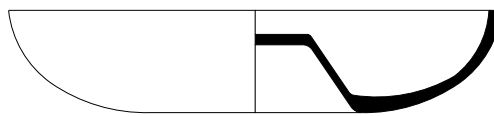
*Exterior**Interior**Profile*

No. 99

Inv. No. MO1186 | Aron 229

Bowl with flat base, truncated umbo,
curved wall, straight edge, flat rim
Anatolia, 18th century

Dimensions: diam. 18.95 cm, h. 3.93 cm, weight 440.6 g

Condition: Good.

Content: A divinatory-ritual bowl with a repertoire of Koranic verses and invocations. *Yā Kāfī, yā Shāfī* type.

Exterior: Below the rim is a continuous profiled inscription of the *Āyat al-Kursī* (Throne Verse, Kor. 2:255-257; Fig. 1), followed by a continuous inscription featuring repeated monograms in square script with the invocation *yā Kāfī yā Shāfī* (O Sufficient! O Pure!). In the middle of the wall are six medallions bearing the repeated monogram *yā Kāfī yā Shāfī*, which also appears in the interstitial spaces. Below them runs another continuous inscription repeating the same monograms in square script. On the base, within the hollow of the umbo, is an invocation in profiled letters. At the centre of the umbo is a magic square.

Interior: Below the rim is a continuous numeric inscription, followed by a continuous profiled inscription of the *Āyat al-Kursī*. Within a composite grid, a mixed numeric and Koranic inscription is present. On the umbo surface is an invocation in profiled script, while the top of the umbo features an inscription with intertwined letters forming an invocation.

Comment: This bowl, together with several others (nos. 90–98, 100), forms a rather homogeneous group characterized mainly by Sunni magical texts and invocations. Many of these are found in the Anatolian region, where they were particularly popular.

References:

Unpublished.



Fig. 1

No. 100

Inv. No. MO1185 | Aron 107



Exterior

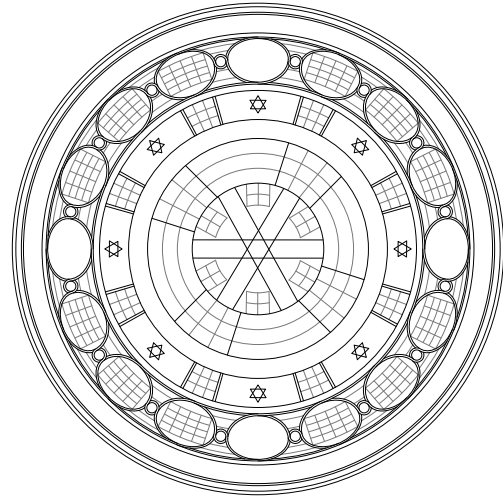

Interior

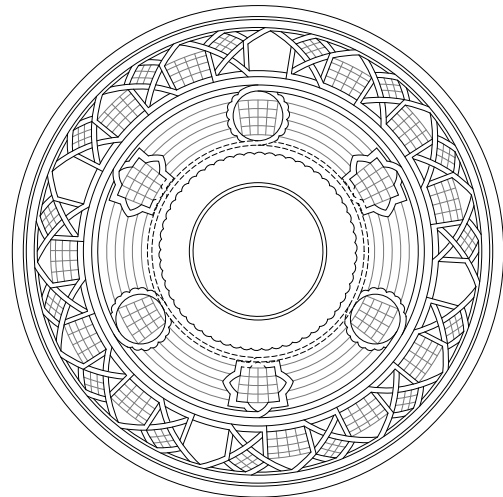

Profile

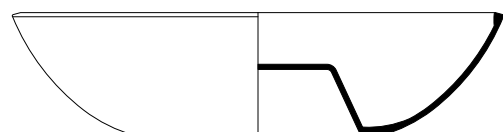

No. 100

Inv. No. MO1185 | Aron 107

Bowl with flat base, truncated umbo,
curved wall, straight edge, flat rim
Anatolia, 17th century

Dimensions: diam. 19.04 cm, h. 4.79 cm, weight 601 g

Condition: Fair; traces of wear.

Content: A divinatory-ritual bowl with a repertoire of Koranic verses and invocations.

Exterior: Below the rim is a continuous inscription explaining the use of the bowl and including a curse against Satan. Beneath it runs a continuous profiled inscription of the *Āyat al-Kursī* (Throne Verse, Kor. 2:255–257; Fig. 1). In the middle of the wall are 15 round medallions containing magic squares. The umbo surface features a grid with four alphanumeric squares and four numeric inscriptions. At the centre is a talisman in the shape of a cross.

Interior: Below the rim is a continuous Koranic inscription, followed by 16 pentagonal cartouches containing alphanumeric grids of 16 and nine boxes. On the umbo surface, there is an invocation written in profiled script.

Comment: This bowl, together with several others (nos. 90–99), forms a rather homogeneous group characterized mainly by Sunni magical texts and invocations. Many of these are found in the Anatolian region, where they were particularly popular.

References: Unpublished.



Fig. 1

No. 101

Inv. No. MO1183 | Aron 408



Exterior

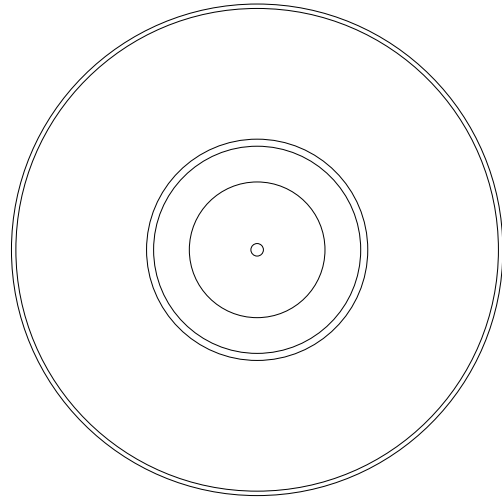

Interior

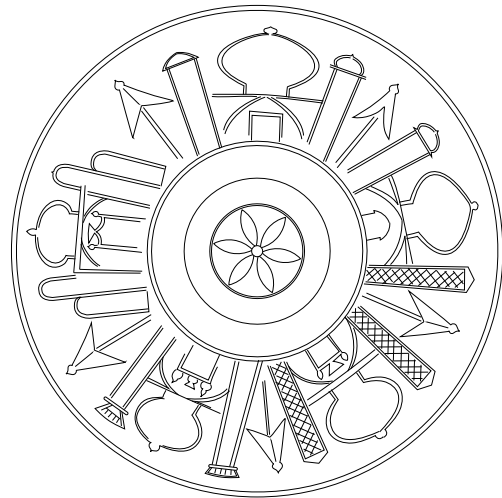

Profile

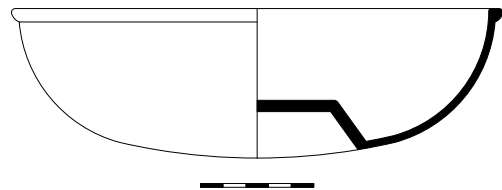

No. 101

Inv. No. MO1183 | Aron 408

**Bowl with flat base, truncated umbo,
curved wall, straight edge, flat rim**
Anatolia or Iran, 20th century

Dimensions: diam. 21.7 cm, h. 6.6 cm, weight 580 g

Condition: Fair; evidence of restoration interventions on the interior.

Content: A divinatory-ritual bowl with a repertoire of Koranic verses and Shi'i invocations.

Exterior: Devoid of decoration.

Interior: Beneath the rim runs a continuous Koranic tex. Below this are five depictions of *turbas* (mausoleums, Figs. 1, 2), representing the tombs of prominent Shi'i figures. Surrounding the umbo is an invocation, while atop the umbo sits a flower motif inscribed with further text.

Comment: This bowl is a late example of a form widespread in Anatolia and Iran.

References: Unpublished.



Fig. 1



Fig. 2

No. 102

Inv. No. MO1190 | Aron 70



Exterior

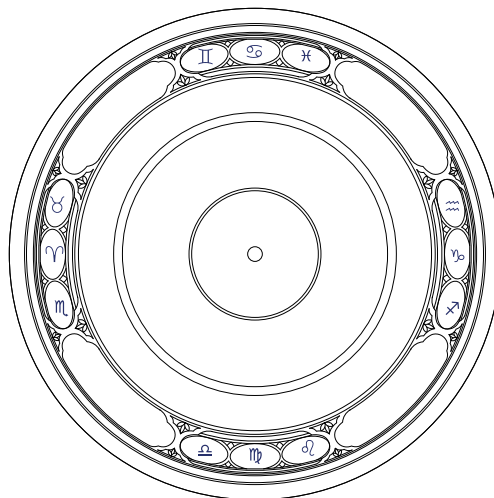

Interior

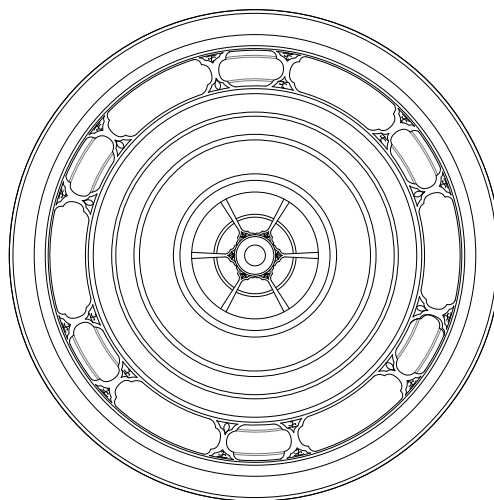

Profile

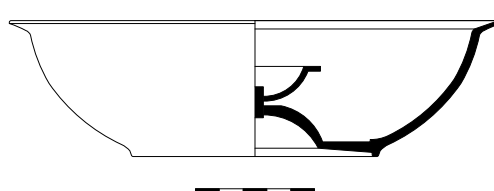

No. 102

Inv. No. MO1190 | Aron 70

Bowl with ring-shaped base, hemispherical umbo surmounted by a small cup with pierced rim; curved wall, horizontally everted rim
Iran, 19th century

Dimensions: diam. 15.35 cm; h. 5.65 cm, weight 343.8 g

Condition: Good.

Content: A divinatory-ritual bowl with Koranic inscriptions and Shi'ī invocations. *Chihil kilūd* type.

Exterior: On the outer surface of the rim is a numerical magical inscription. Below it is an inverted Koranic inscription. In the centre, eight oval cartouches are arranged in two groups: the first contains a single large Koranic text, while the second consists of three bands. The upper and lower bands feature Koranic verses, and the middle band displays the signs of the zodiac (Fig. 1). The base is surrounded by a continuous Koranic inscription.



Fig. 1

Interior: A continuous Koranic inscription is placed on the inner surface of the rim. Below it, another continuous inscription features the *Āyat al-Kursī* (the Throne Verse, Kor. 2:255). In the central area, there are 10 medallions—six oval and four circular—containing Koranic texts. The oval medallions display larger-format texts and invocations to the angels Jibrā'īl, Mikā'īl, Azrā'īl, and Isrāfīl, while the circular medallions contain the invocation *yā Kāfi*, *yā Shāfi*. Two lower parallel bands also bear Koranic texts, and around the umbo appears the *Chahārdah ma'sūm*. Below this is a continuous inscription with the *Nādi 'Aliyyan* (“Call upon 'Alī”). The umbo features a quadripartite cartouche with additional Koranic texts. On the upper wall of the umbo, a plate with a perforated rim is screwed in place to hold the “Forty Keys” (*Chihil kilūd*), used in magical-divinatory practices (Fig. 3).



Fig. 2

Comment: This bowl of great complexity features a wide repertoire of texts. The so-called *Chihil kilūd* bowls are still used in Iran for divinatory practices.

References: Unpublished.



Fig. 3

No. 103

Inv. No. MO1241 | Aron 179



Exterior

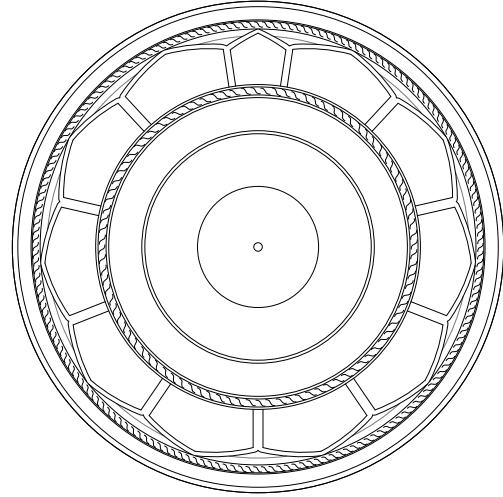

Interior

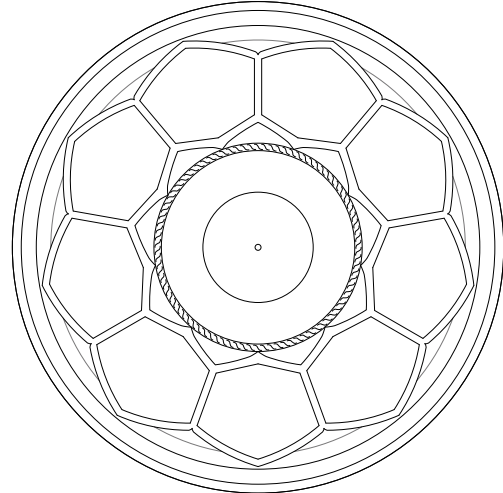

Profile

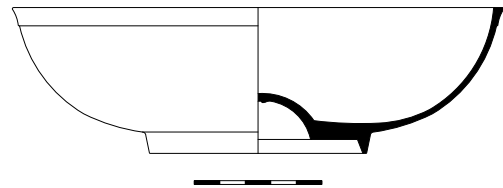

No. 103

Inv. No. MO1241 | Aron 179

Bowl with ring-shaped base, hemispherical umbo, curved wall, straight edge, flat rim
India, 17-18th century

Dimensions: diam. 19.28 cm, h. 5.72 cm, weight 585 g

Condition: Good; traces of erasure on the inside.

Content: A divinatory-ritual bowl with a repertoire of Koranic verses and invocations.

Exterior: An upper band features a continuous Koranic inscription. The wall is decorated with a sequence of 11 pentagonal cartouches containing Koranic inscriptions (Fig. 1). Around the surface of the umbo, there is a continuous two-line Koranic text.

Interior: On the upper wall, a continuous inscription features the *Āyat al-Kursī* (the Throne Verse, Kor. 2:255). In the centre of the wall, 11 hexagonal cartouches contain invocations. In the interstitial spaces above the hexagons are magical numerical inscriptions. Around the umbo, a Koranic inscription continues in minute script over three lines, extending onto the surface of the umbo with four additional lines, though much of it is largely obliterated (Fig. 2).

Comment: This bowl exhibits Indian characteristics in terms of shape, execution technique, and decorative style.

References: Unpublished.



Fig. 1



Fig. 2

No. 104

Inv. No. MO1173 | Aron 451



Exterior

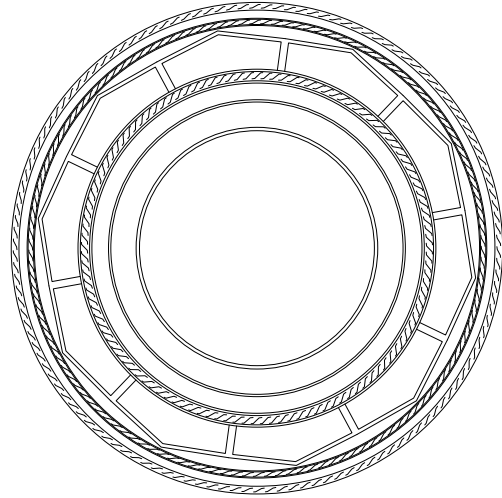

Interior

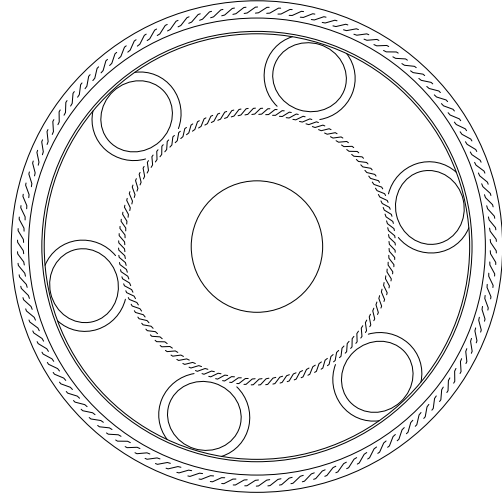

Profile

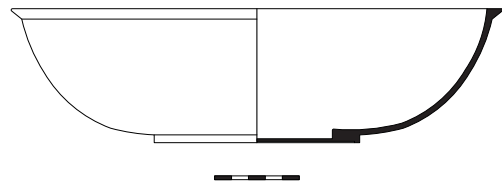

No. 104

Inv. No. MO1173 | Aron 451

Bowl with ring base, hemispherical umbo, curved wall,
straight edge, with rim replaced by a metal plaque
India, 18th century

Dimensions: diam. 29 cm, h. 7.92 cm

Condition: Fair; the umbo has been replaced by a flat metal plate.

Content: A divinatory-ritual bowl with a repertoire of Koranic verses and invocations.

Exterior: An upper band features a continuous Koranic inscription. The surface of the wall is decorated with a sequence of 12 pentagonal cartouches, each containing Koranic verses (Fig. 1).

Interior: On the upper wall, a continuous inscription with the *Āyat al-kursī* (the Throne Verse, Kor.: 2:255). The interior wall is unreadable.

Comment: This bowl exhibits Indian characteristics in its shape, execution technique, and decorative motifs.

References: Unpublished.



Fig. 1

No. 105

Inv. No. MO1244 | Aron 349



Exterior

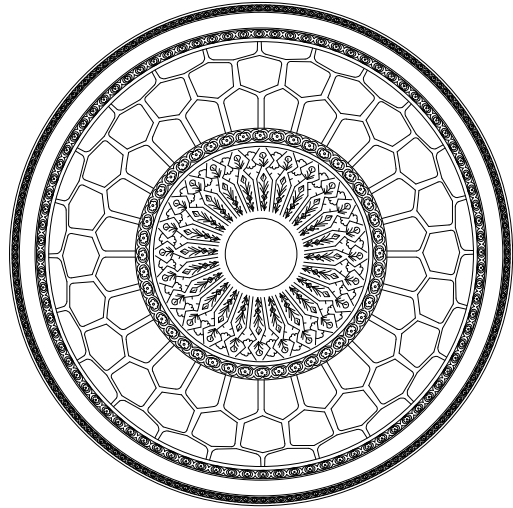

Interior

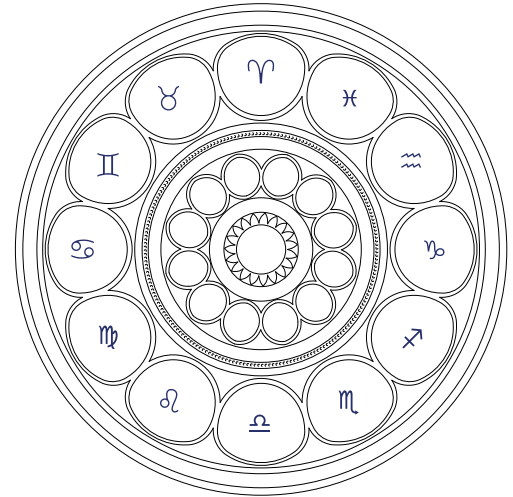

Profile

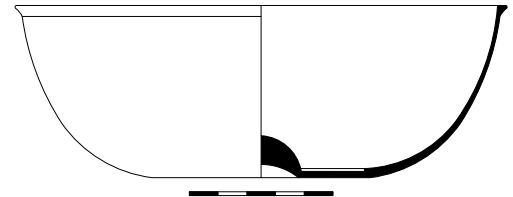

No. 105

Inv. No. MO1244 | Aron 349

Bowl with flat base, hemispherical umbo, curved wall, slightly everted edge and flat rim
Iran, 1240/1834–35

Dimensions: diam. 17.15 cm, h. 6 cm, weight 369 g

Condition: Good.

Content: A divinatory-ritual bowl.

Exterior: In the upper band below the rim, a continuous inscription features the *Chahārdah ma‘šūm* (“The Fourteen Infallibles”) along with the date of the bowl. In the lower band, a grid of 75 hexagons and semi-hexagons contains a Persian *ġazal* (ode). On the base, 24 pentagonal spear-shaped elements decorated with floral motifs on the inside are arranged in a sunburst pattern around the hollow of the umbo.

Interior: In the upper band below the rim, there are three continuous inscriptions containing the *Āyat al-Kursī* (The Throne Verse, Kor. 2:255). Below these, two continuous inscriptions feature additional Koranic texts. In the centre of the wall, the 12 signs of the zodiac are engraved within circular medallions (Figs. 1–2), each accompanied by a caption naming the corresponding sign in the interstitial spaces. Around the umbo, 12 invocations include the names of angels within roundels. A further continuous inscription, decorated with a lotus motif, surrounds the umbo.

Comment: Although the bowl belongs to a type common in the Safavid period, its distinctive feature is the inclusion of verses inspired by the Sufi poetry of Rumi, likely the work of a local author. This characteristic appears typical of the Qajar period, as confirmed by the date (1240/1834–35; Fig. 3) and the style of the bowl.

References: Unpublished.

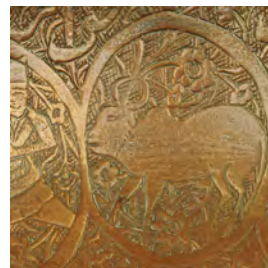

Fig. 1

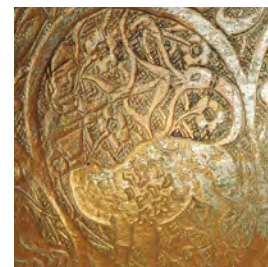

Fig. 2



Fig. 3

No. 106

Inv. No. MO1245 | Aron 438

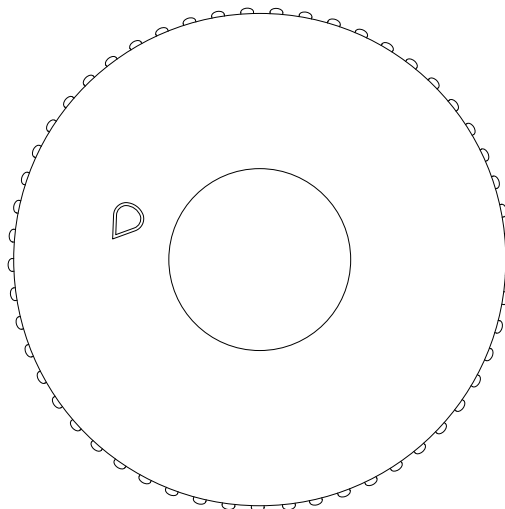
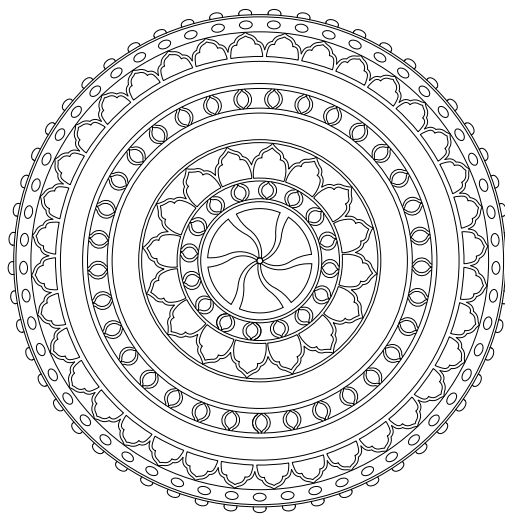
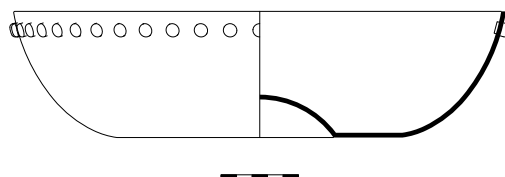
*Exterior**Interior**Profile*

No. 106

Inv. No. MO1245 | Aron 438

**Bowl with flat base, hemispherical umbo,
curved wall with studs at the top
Central Asia, 19th century**

Dimensions: diam. 31.7 cm, h. 8.15 cm

Condition: Good.

Content: A divinatory-ritual bowl with priers and invocations.

Exterior: The outer surface has no ornamentation, except for 52 circular studs on the upper end of the wall.

Interior: Below the rim are 52 small trilobed arches, each containing an invocation dedicated to 'Alī, repeated 52 times. Below these are 52 rectangular panels with additional serial invocations (Fig. 1). Further down, there are 32 pointed oval shapes containing magical inscriptions, with repeated invocations in the interstitial spaces. This is followed by another set of 52 rectangular panels featuring invocations. The umbo is surrounded by two circular bands: the outer band has 16 arch-shaped cartouches containing invocations, while the inner band has 16 pointed oval medallions featuring the same term as those in the previously described medallions. The umbo itself is formed by six inscribed triangular segments.

Comment: Central Asian bowl, probably from Transoxiana.

References: Unpublished.



Fig. 1

No. 107

Inv. No. MO1191 | Aron 283

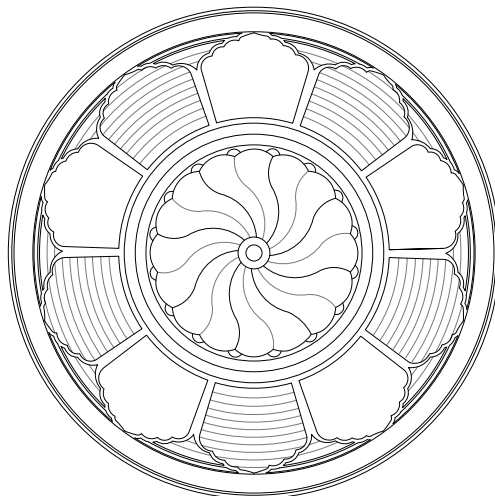
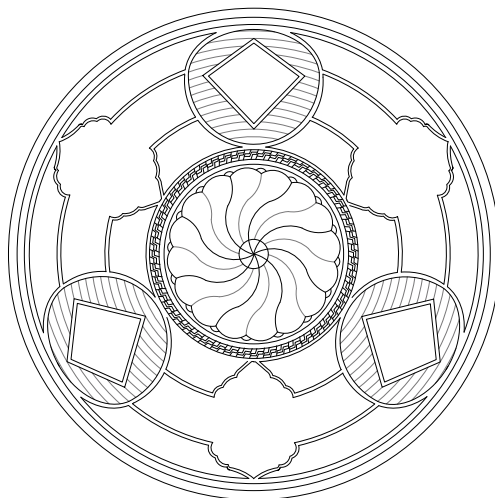
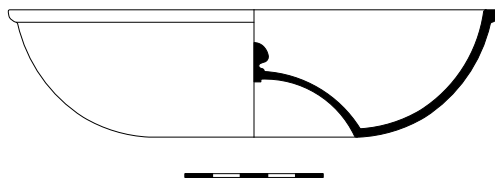
*Exterior**Interior**Profile*

No. 107

Inv. No. MO1191 | Aron 283

Bowl with flat base, hemispherical umbo with grooves;
curved wall, horizontal and slightly everted rim
Egypt or Turkey (?), 20th century (?)

Dimensions: diam. 17.8 cm, h. 4.61 cm, weight 525 g

Condition: Good.

Content: A fake divinatory-ritual bowl.

Exterior: The bowl is certainly a fake of uncertain date, presumably from the 20th century. Its ornamental design imitates fairly common models—for example, the continuous inscription below the rim and the five pentagonal niches containing pseudo-inscriptions that mimic Arabic texts, alternating with five niches featuring pseudo-magical number series (Fig. 1).

Interior: The decorative layout also indicates that it is a fake, imitating established models.

Comment: This bowl is a rarity and was made by someone completely unfamiliar with the Arabic alphabet. It is a case of forgery, reflecting an attempt to create objects based on existing models with the specific intention of placing them on the antiques market.

References: Unpublished.



Fig. 1

No. 108

Inv. No. MO1192 | Aron 332



Exterior

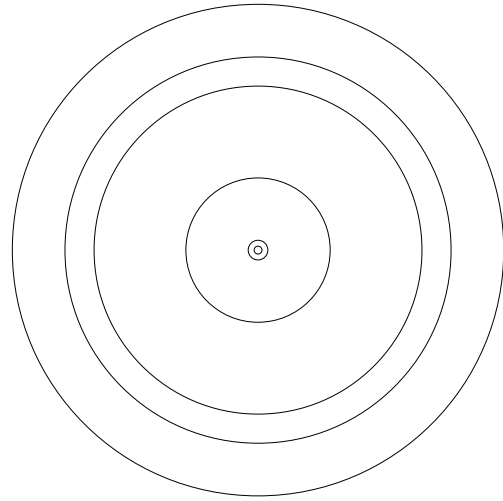

Interior

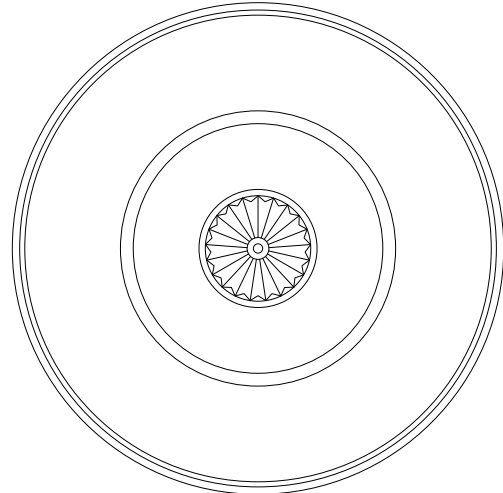

Profile

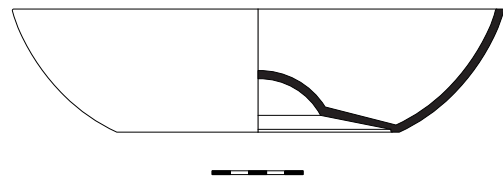

No. 108

Inv. No. MO1192 | Aron 332

**Bowl with flat base, hemispherical umbo,
curved wall, straight edge, flat rim**
Syria or Egypt, 20th century

Dimensions: diam. 28.9 cm, h. 8.3 cm

Condition: Good; small suspension hole pierced through the wall.

Content: This bowl is a fake, inspired by metal objects from the Mamluk era.

Exterior: Devoid of decoration.

Interior: The profiled inscription covers the entire interior surface in two parallel bands. The band along the wall features Mamluk titling with numerous writing errors. The same inscription, exhibiting similar errors, is repeated around the umbo (Fig. 1).

Comment: This bowl has no comparable examples.

References: Unpublished.



Fig. 1

Main Bibliographic References on Islamic Magic Bowls

Aksoy 1976

O. Aksoy, Türk Şifa Tasları. *Türk Etnoğrafya Dergisi* 15, 1976, pp. 35-54.

Allan 1986

J.W. Allan, *Metalwork of the Early Islamic World. The Aron Collection*. London 1986.

Bernardini in press

M. Bernardini, *The Aron Collection II: Islamic Divinatory-Ritual Bowls*. Rome in press.

Canaan 1914

T. Canaan, *Aberglaube und Volksmedizin im Lande der Bibel*. Hamburg 1914.

Canaan 1923

T. Canaan, Ṭāsīt er-radjfeh (Fear Cup). *Journal of Palestinian Oriental Society* 3, 1923, pp. 122-31.

Canaan 1936

T. Canaan, Arabic Magic Bowls. *Journal of Palestinian Oriental Society* 16, 1936, pp. 79-127.

Elemterefiş 2006

Elemterefiş. Anadolu'da Büyü ve İnanışlar. Catalogue ed. by Ş. Şentürk. Istanbul 2006.

Flood 2017

F.B. Flood, *Technologies de dévotion dans les arts de l'Islam : Pèlerins, reliques et copies*. Paris 2017.

Giunta 2018

R. Giunta, *The Aron Collection I: Islamic Magic-Therapeutic Bowls*. Rome 2018.

Ivanov 2014

A. Ivanov, *Iranian Copper and Bronze (Brass) Artefacts from the Second Half of the 14th to the Mid-18th Century* (The State Hermitage Museum. Catalogue of the Collection). St. Petersburg 2014.

Karami 2021

L. Karami, Observations on the *Jām-e Čehel Kelid*. Notes on the Text and Context. *Oriente Moderno* 101, 2021, pp. 70-93.

Langer 2013

E. Langer, *Islamische magische Schalen und Teller aus Metall. Medizinschalen und Wahrsageteller sowie Liebesschalen und -teller / Islamic Magic Medicinal Bowls. Divination Bowls*. Münster 2013.

Melikian-Chirvani 1982

A.S. Melikian-Chirvani, *Islamic Metalwork from the Iranian World. 8th-18th Centuries*. London 1982.

Melikian-Chirvani 1991

A.S. Melikan-Chirvani, From the Royal Boat to the Beggar's Bowl. *Islamic Art* 4, 1991, pp. 3-111.

Perk, Paksoy 2011

H. Perk, İ.G. Paksoy, *Duanin Sudaki Gizemi. Şifa Tasları, Halûk Perk Koleksiyonu*. Istanbul 2011.

Rehatsek 1871-74

E. Rehatsek, Explanations and Facsimiles of Eight Arabic Talismanic Medicine-Cups. *Journal of the Bombay Branch of the Royal Asiatic Society* 10, 1871-74, pp. 150-62.

Rehatsek 1874

E. Rehatsek, An Arabic Talismanic Cup, Used Chiefly in Cases of Parturition. *The Indian Antiquary, A Journal of Oriental Research* 3, 1874, pp. 36-40.

Reinaud 1828

M. Reinaud, *Monuments arabes, persans et turcs du cabinet de M. le Duc de Blacas*, 2 Vols. Paris 1828.

Roşu 1992

A. Roşu, Une coupe magique d'époque moghole au Musée Guimet. *Journal Asiatique* 280, 1992, pp. 251-77.

Savage-Smith 1997

E. Savage-Smith, Magic-Medicinal Bowls, in F. Maddison, E. Savage-Smith (Eds.), *Science, Tools and Magic. Part One: Body and Spirit, Mapping the Universe. Part Two: Mundane Worlds* (The Nasser D. Khalili Collection of Islamic Art, XII, General Editor J. Raby). Oxford 1997.

Savage-Smith 2003

E. Savage-Smith, Safavid Magic Bowls, in J. Thompson, Sh.R. Canby (Eds.), *Hunt for Paradise: Court Arts of Safavid Iran, 1505-1576*, pp. 240-47. Milan 2003.

Spoer 1935

H.H. Spoer, Arabic Magic Medicinal Bowls. *Journal of the American Oriental Society* 55/3, 1935, pp. 237-56.

Spoer 1938

H.H. Spoer, Arabic Magic Bowls II: An Astrological Bowl. *Journal of the American Oriental Society* 58/2, 1938, pp. 366-83.

Wiet 1932

G. Wiet, *Objets en cuivre* (Catalogue Général du Musée Arabe du Caire). Le Caire 1932.

Ya Kafi, Ya Shafi 1998

Ya Kafi, Ya Shafi, The Tawfik Canaan Collection of Palestinian Amulets: An Exhibition, October 30, 1998 - February 25, 1999, ed. by Kh. Nashef. Bir Zeyt 1998.

Zéki Pacha 1916-17

A. Zéki Pacha, Coupe magique dédiée à Şalāḥ ad-Dīn (Saladin). Titres royaux, tolérance et portrait de Şalāḥ ad-Dīn. *Bulletin de l'Institut Égyptien* 10, 1916-17, pp. 241-89.

Annex I

ANTHROPOMORPHIC AND ZOOMORPHIC REPRESENTATIONS



Cross-legged human figure



No. 4



No. 6

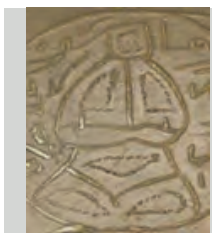

No. 7

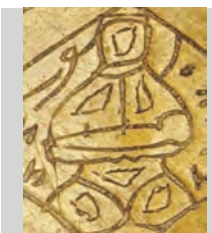

No. 8



No. 9

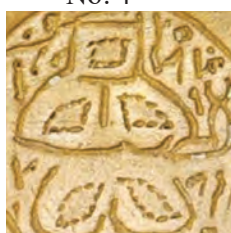

No. 10



No. 11



No. 12



No. 13

Quadruped

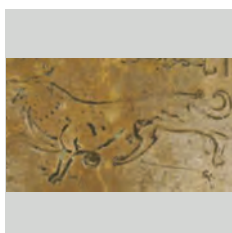

No. 1

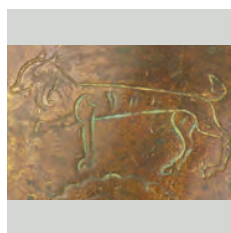

No. 3



No. 4



No. 6



No. 8



No. 9



No. 10



No. 11



No. 12



No. 13

Scorpion



No. 1



No. 3



No. 6



No. 7



No. 8



No. 9



No. 10



No. 11



No. 12



No. 13

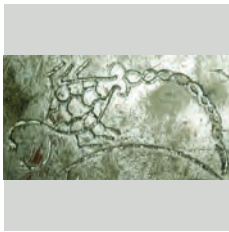

No. 16

Lizard

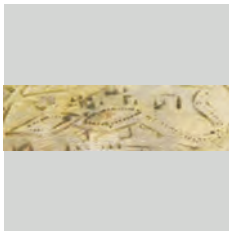

No. 4

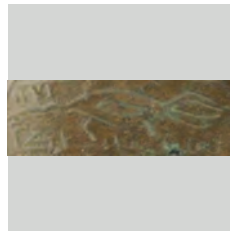

No. 6



No. 7

Serpent with knotted body



No. 3



No. 4



No. 7



No. 8



No. 9



No. 10



No. 11



No. 12

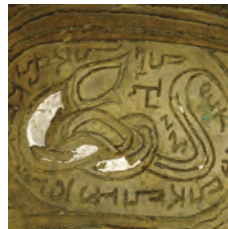

No. 13

Serpent

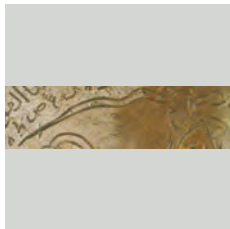

No. 1



No. 6

Twin-headed dragon with knotted body

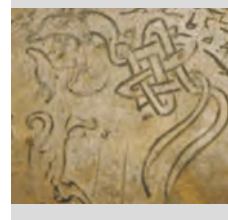

No. 1

Bird with spread wings



No. 4



No. 8

Hourse



No. 4

Annex II

THE 12 SIGNS OF THE ZODIAC



Aries



No. 13



No. 27



No. 28



No. 42



No. 46



No. 47



No. 48



No. 49



No. 53



No. 63



No. 64



No. 68



No. 69



No. 71



No. 77



No. 78

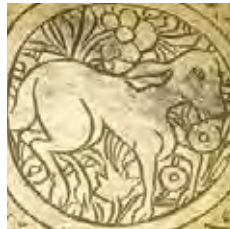

No. 82



No. 86



No. 102



No. 105

Taurus



No. 13



No. 27



No. 28



No. 42



No. 46



No. 47



No. 48



No. 49



No. 53



No. 63



No. 64



No. 68



No. 69



No. 71



No. 77



No. 78

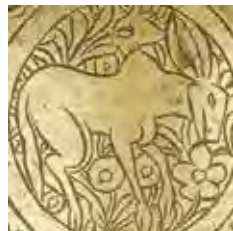

No. 82



No. 86



No. 102



No. 105

Gemini



No. 13



No. 27



No. 28



No. 42



No. 46



No. 47



No. 48



No. 49



No. 53



No. 63



No. 64



No. 68



No. 69



No. 71



No. 77



No. 78

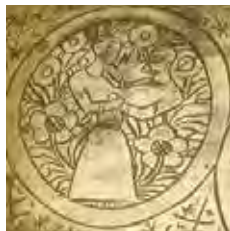

No. 82



No. 86



No. 102



No. 105

Cancer



No. 13



No. 27



No. 28



No. 42



No. 46



No. 47



No. 48



No. 49



No. 53



No. 63



No. 64



No. 68



No. 69



No. 71



No. 77



No. 78

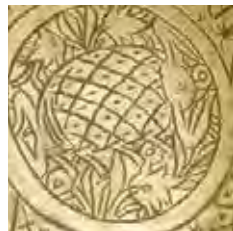

No. 82



No. 86



No. 102



No. 105

Leo



No. 13



No. 27



No. 28



No. 42



No. 46



No. 47



No. 48



No. 49



No. 53



No. 63



No. 64



No. 68



No. 69



No. 71



No. 77



No. 78



No. 82



No. 86

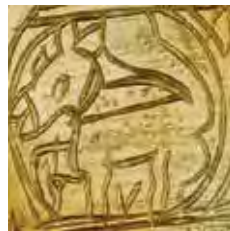

No. 102



No. 105

Virgo



No. 13



No. 27



No. 28



No. 42



No. 46



No. 47



No. 48



No. 49



No. 53



No. 63



No. 64



No. 68



No. 69



No. 71



No. 77



No. 78



No. 82



No. 86



No. 102



No. 105

Libra



No. 13



No. 27



No. 28



No. 42



No. 46



No. 47



No. 48



No. 49



No. 53



No. 63



No. 64



No. 68



No. 69



No. 71



No. 77



No. 78



No. 82

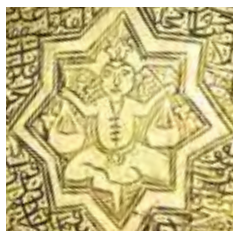

No. 86



No. 102



No. 105

Scorpio



No. 13



No. 27



No. 28



No. 42



No. 46



No. 47



No. 48



No. 49



No. 53



No. 63



No. 64



No. 68



No. 69



No. 71



No. 77



No. 78



No. 82



No. 86



No. 102



No. 105

Sagittarius



No. 13



No. 27



No. 28



No. 42



No. 46



No. 47



No. 48



No. 49



No. 53



No. 63



No. 64



No. 68



No. 69



No. 71

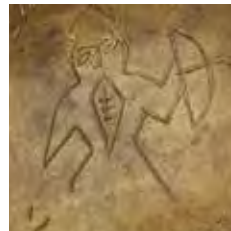

No. 77



No. 78



No. 82

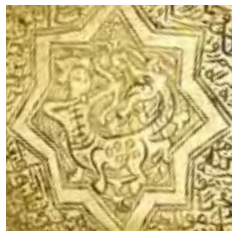

No. 86



No. 102



No. 105

Capricorn



No. 13



No. 27



No. 28



No. 42



No. 46



No. 47



No. 48



No. 49



No. 53



No. 63



No. 64



No. 68



No. 69



No. 71



No. 77



No. 78



No. 82



No. 86



No. 102



No. 105

Aquarius



No. 13



No. 27



No. 28



No. 42



No. 46



No. 47



No. 48



No. 49



No. 53



No. 63



No. 64



No. 68



No. 69



No. 71



No. 77



No. 78



No. 82



No. 86



No. 102



No. 105

Pisces

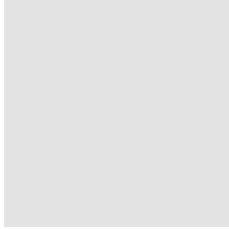

No. 13



No. 27



No. 28



No. 42



No. 46



No. 47



No. 48



No. 49



No. 53



No. 63



No. 64



No. 68

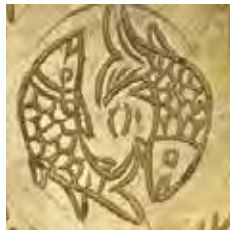

No. 69



No. 71



No. 77



No. 78



No. 82



No. 86

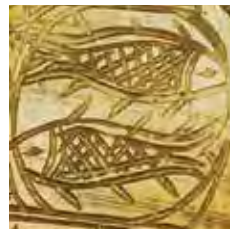

No. 102



No. 105